

## SECTION 15

# INTAKE & EXHAUST

### CONTENTS

General.....	1	Inter-cooler water spray.....	2
Servicing standards .....	1	Secondary air control system .....	4
Special tools.....	1	Inlet manifold .....	5
On-vehicle servicing.....	1	Exhaust manifold and turbocharger.....	8
Turbocharger super charging pressure check .....	1		

### General

The following servicing guidelines have been prepared for vehicles which use the 4G63-MIVEC-T/C engine. Other servicing guidelines remain unchanged.

- Changes to the turbocharger supercharging pressure
- Changes to the inter-cooler water spray hose
- Changes to the secondary air control valve
- Changes to the inlet manifold
- Changes to the exhaust manifold and the turbocharger

### Servicing standards

Item	Standard value
Turbocharger charging pressure kPa	97~157

### Special tools

Tool	Number	Name	Function
	MD998770	O <sub>2</sub> sensor wrench	Removal and fitting of the O <sub>2</sub> sensor

### On-vehicle servicing

#### Turbocharger supercharging pressure check

The standard value for the turbocharger charging pressure has been changed. Other servicing guidelines remain unchanged.

**Standard value: 97 ~ 157 kPa**

Inter-cooler water spray

Removal and fitting

<Water spray nozzle, hose and washer tank>

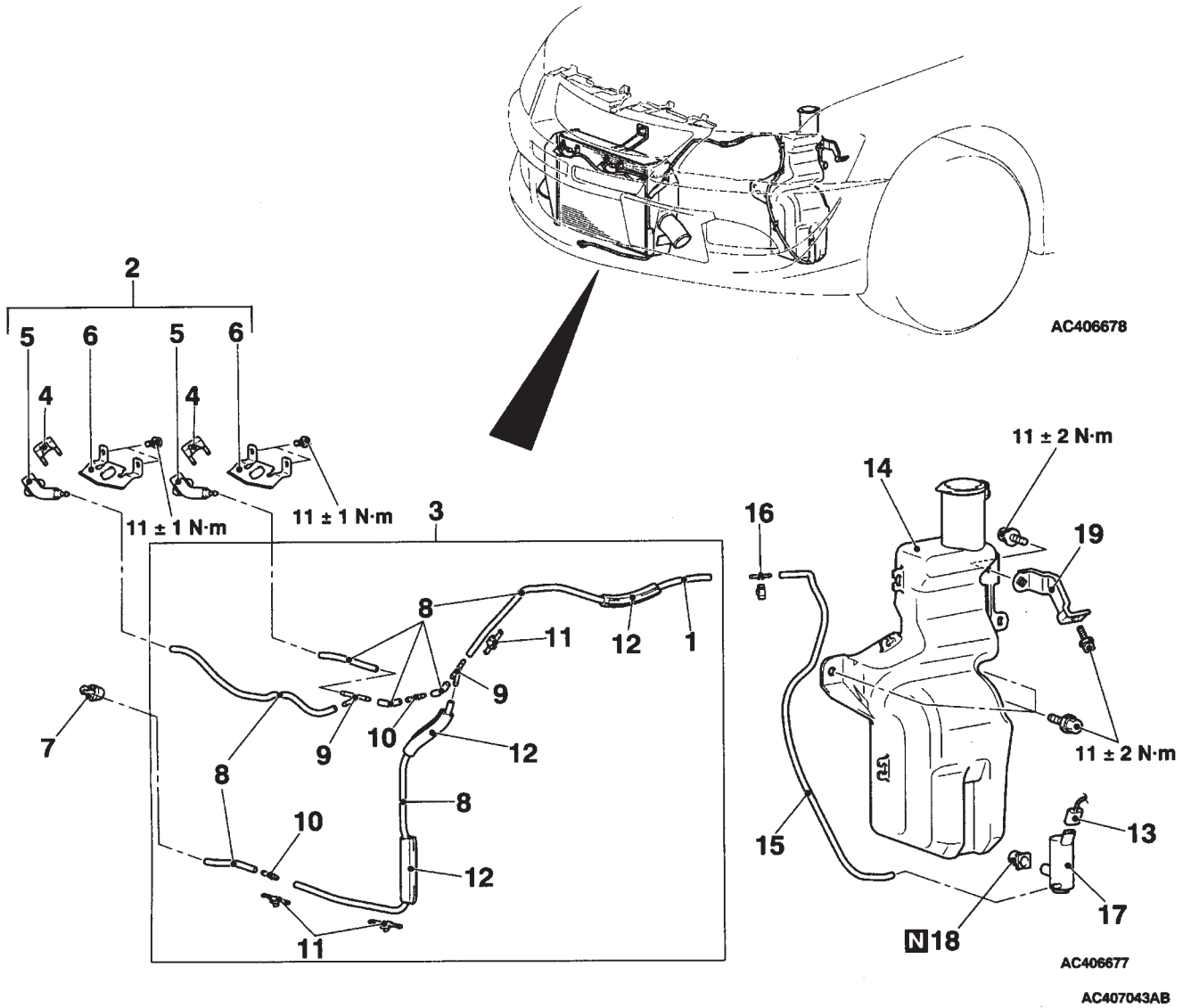

Procedure for removing the water spray nozzle and the hose

1. Water spray hose connection
  - Front bumper ASSY (Ref: Section 51)
- ▶ A ◀ • Tape (for fitting the water spray hose ASSY)
- ▶ A ◀ 2. Water spray nozzle ASSY
- ▶ A ◀ 3. Water spray hose ASSY
4. Clamp
5. Water spray nozzle (top)
6. Water spray nozzle bracket
7. Water spray nozzle (bottom)
8. Water spray hose
9. Three-way joint

10. Washer valve

- Tape (for attaching clip)
- 11. Clip
- 12. Pad

Procedure for removing the washer tank

1. Water spray hose connection
13. Water spray motor connector
14. Washer tank
15. Water spray hose
16. Washer valve
17. Water spray motor
18. Packing
19. Bracket

**Fitting guidelines**

▶ A ◀ **Fitting the water spray hose ASSY and fixing tape (for securing the water spray hose ASSY)**

1. After fitting the water spray hose, the three-way joint and the washer valve, affix pads, clips and tape at the positions shown in the water spray hose diagram.

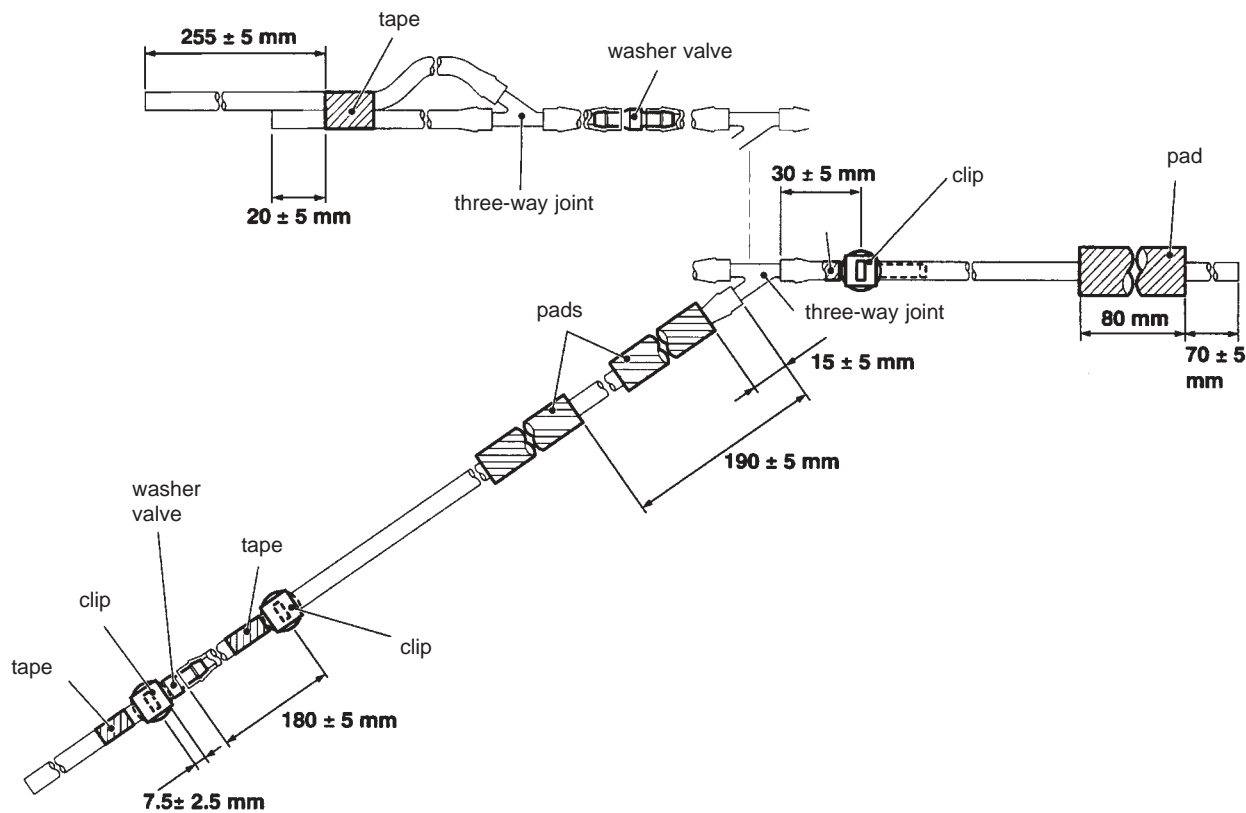

AC500648AB

2. Fit the water spray hose ASSY to the front bumper using the water spray hose ASSY clip.
3. Affix tape as shown in the diagram, so that the water spray hose ASSY does not slip.

**View of the inside of the front bumper**

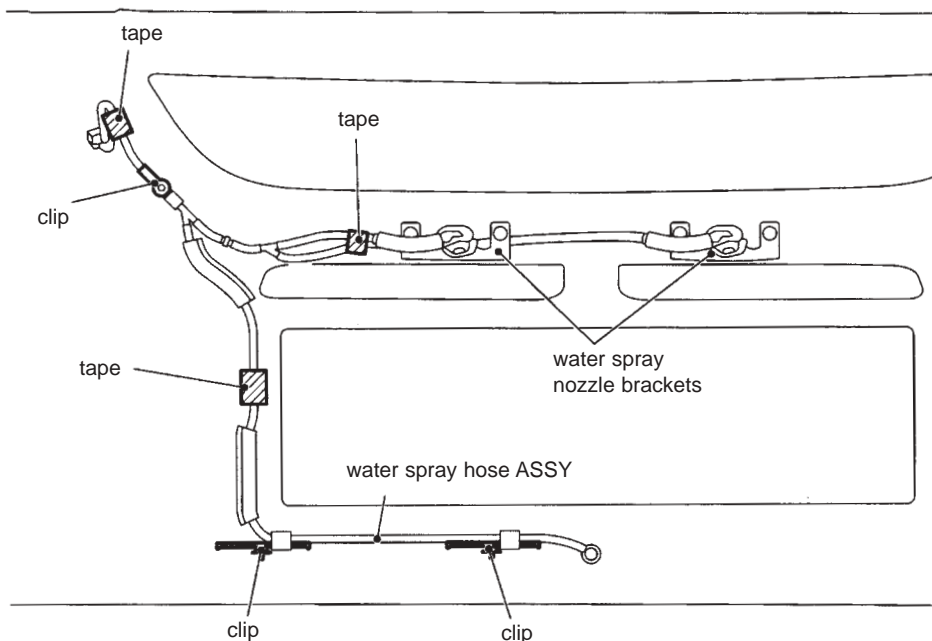

AC406668AB

**Secondary air control system**  
**Removal and fitting**

**Jobs to be completed before removal and after fitting**

- Removal and refitting of the air duct
- Removal and refitting of the strut tower bar

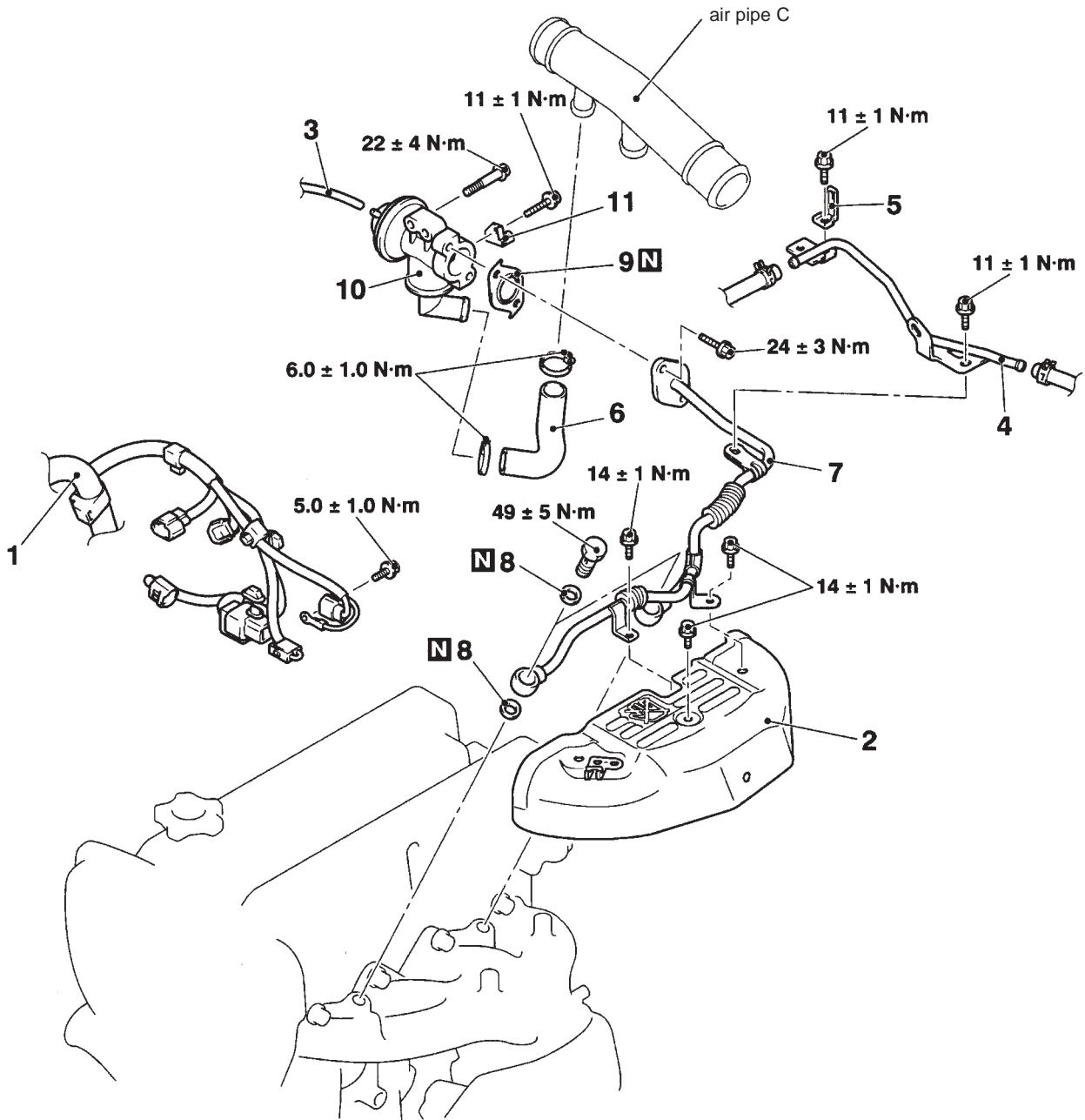

AC406679AB

**Removal procedure**

1. Control harness connection
2. Heat protector
3. Vacuum hose connection
  - Air pipe C
4. Vacuum pipe
5. Harness bracket

6. Air hose
7. Air pipe ASSY
8. Gasket
- ▶ A ◀ 9. Gasket
10. Secondary air control valve
11. Harness bracket

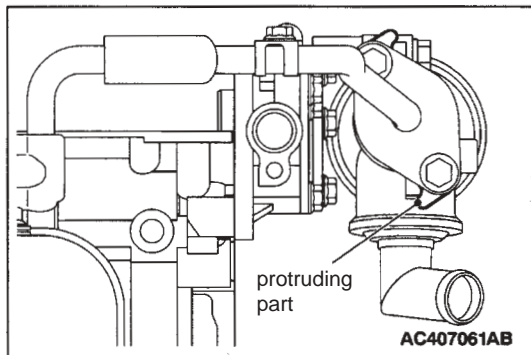

**Fitting guidelines**

▶ A ◀ **Fitting the gasket**

Fit the gasket so that the protruding part points in the direction shown in the diagram.

**Inlet manifold  
Removal and fitting**

**Jobs to be completed before removal and after fitting**

- Take measures to prevent fuel leaking (only before removal)
- Removal and refitting of the valence (Ref Section 15: Front bumper)
- Draining and refilling the coolant
- Removal and refitting of the air duct

- Removal and refitting of the strut tower bar
- Removal and refitting of the throttle body
- Removal and refitting of the secondary air control valve (Ref P15-4)
- Removal and refitting of the cross member bar
- Removal and refitting of the front exhaust pipe

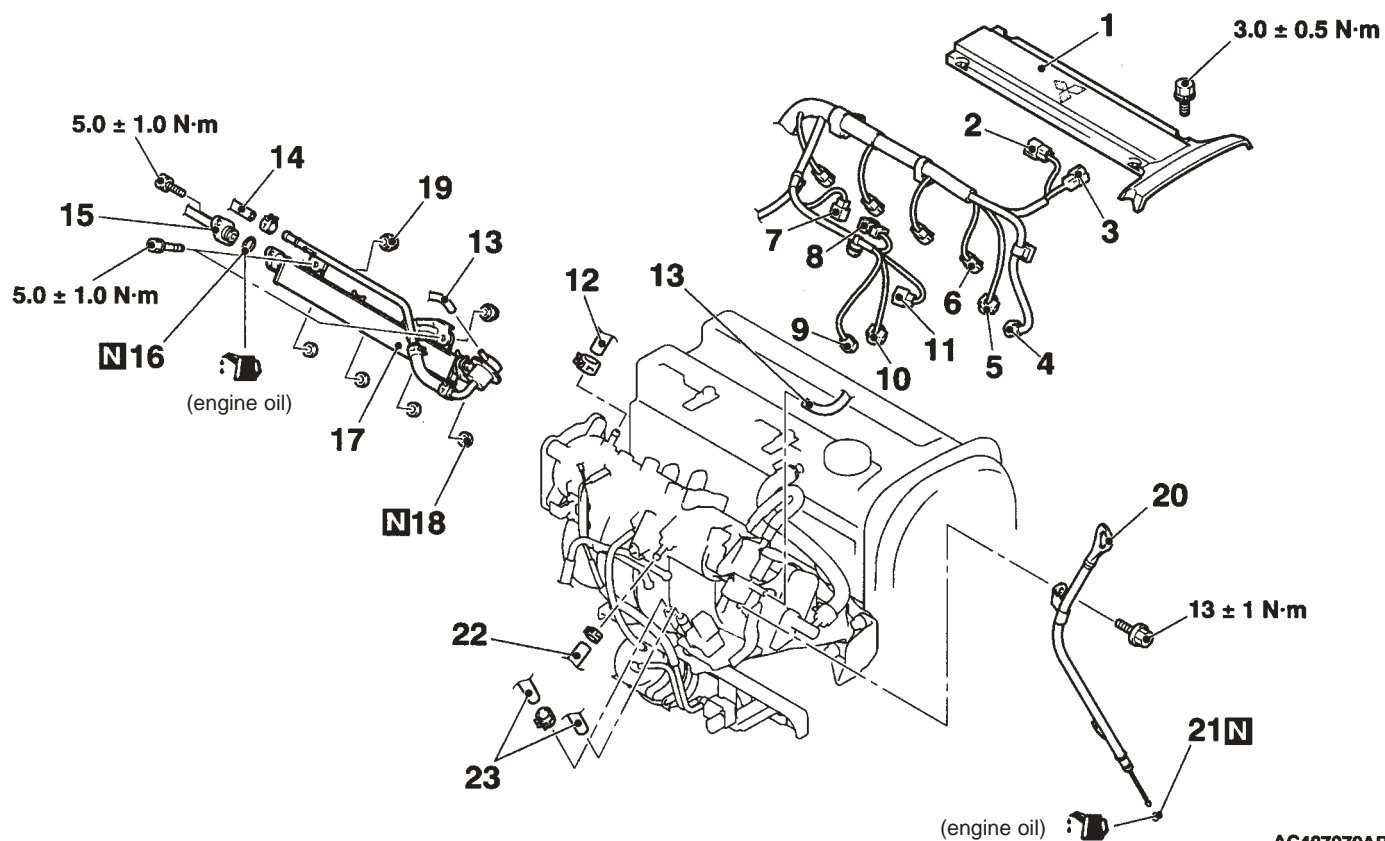

**Removal procedure**

1. Centre cover
2. Ignition coil connector
3. O<sub>2</sub> sensor connector
4. Oil feeder control valve connector
5. Crank angle sensor connector
6. Injector connector
7. Air temperature sensor connector
8. Manifold absolute pressure sensor connector
9. Purge control solenoid valve connector
10. Knock sensor connector
11. Fuel pressure solenoid valve connector

12. Vacuum hose connection
13. Vacuum hose connection
14. Fuel return hose connection
- ▶ A ◀ 15. Fuel high pressure hose connection
- ▶ A ◀ 16. O-ring
- ◀ A ▶ 17. Delivery pipe, injector and fuel pressure regulator ASSY
18. Insulator
19. Insulator
20. Oil level gauge & guide ASSY
21. O-ring
22. Brake booster vacuum hose connection
23. Purge hose connection

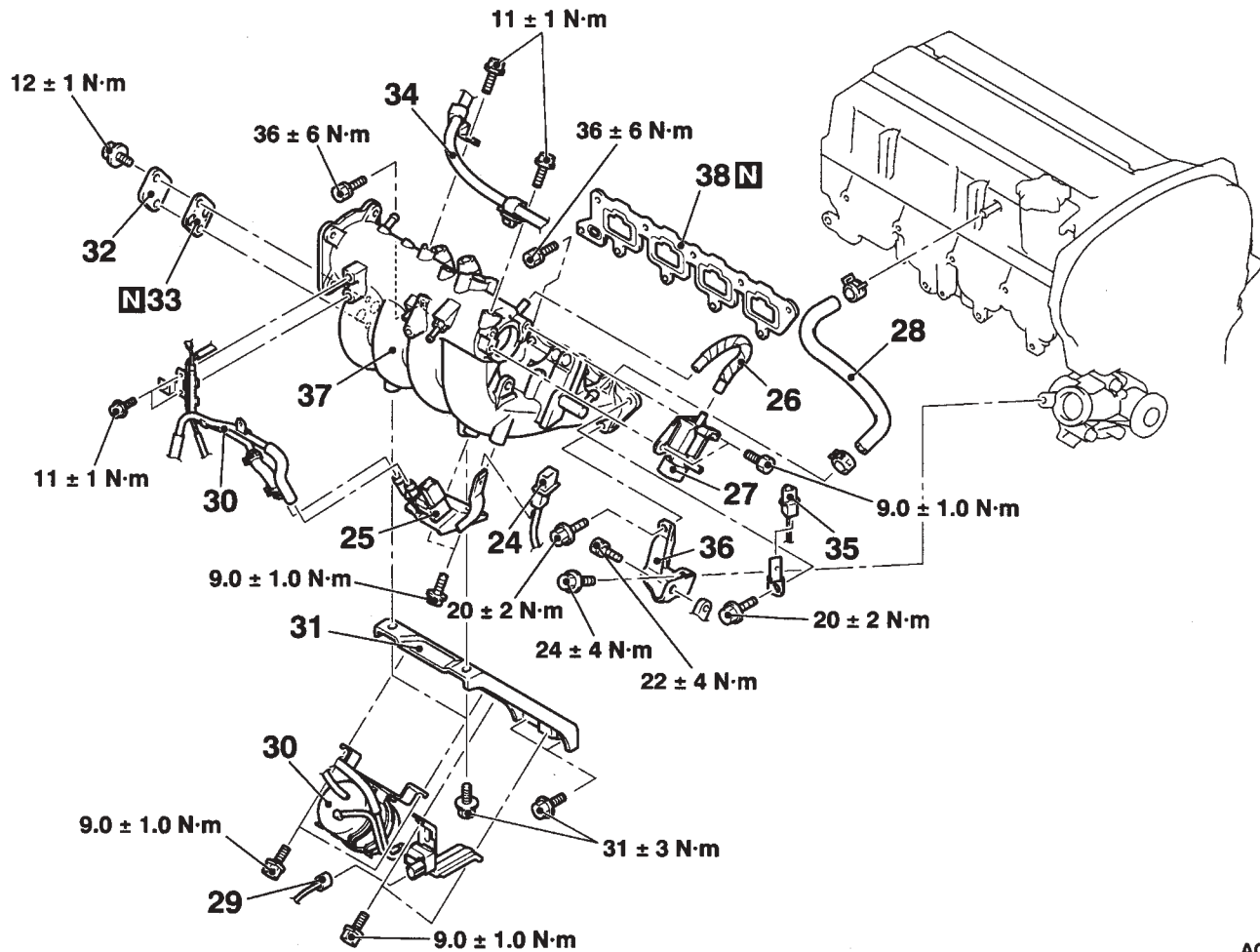

**Removal procedure**

- 24. Knock sensor connector
- 25. Purge control solenoid valve ASSY
- 26. Vacuum hose
- 27. Fuel pressure solenoid valve ASSY
- 28. PCV hose
  - Alternator (Ref Section 16: Alternator)
- 29. Secondary air control solenoid valve connector
- 30. Vacuum tank, ACV solenoid valve, vacuum hose & pipe ASSY
- 31. Inlet manifold stay
- 32. Cover
- 33. Gasket
- 34. Harness connection
- 35. Crank angle sensor connector
- 36. Alternator bracket
- 37. Inlet manifold
- 38. Inlet manifold gasket

**Removal guidelines****◀ A ▶ Removal of the delivery pipe, the injector and the fuel pressure regulator ASSY**

Remove the delivery pipe, with the injector and the fuel pressure regulator intact.

**Caution**

**When removing the delivery pipe, be careful not to drop the injector.**

**Fitting guidelines****▶ A ◀ Connecting the O-ring and the fuel high pressure hose**

1. Apply a small quantity of fresh engine oil to the O-ring, and insert it into the delivery pipe without damaging the O-ring.
2. Check that the high pressure hose can be turned smoothly. If it cannot be turned smoothly there is a possibility that it is biting into the O-ring, so remove the high pressure hose and check for any damage to the O-ring. If the O-ring is undamaged, reinsert it into the delivery pipe and check once more whether the hose can be turned smoothly.
3. Tighten the mounting bolt to the specified torque.

**Tightening torque: 5.0 ± 1.0 N·m**

## Exhaust manifold and turbocharger

### Removal and fitting

**Jobs to be completed before removal and after fitting**

- Removal and refitting of the valence
- Removal and refitting of the radiator
- Removal and refitting of the air intake hose and air hose A
- Removal and refitting of the cross member bar
- Removal and refitting of the front exhaust pipe
- Draining and refilling of the engine oil

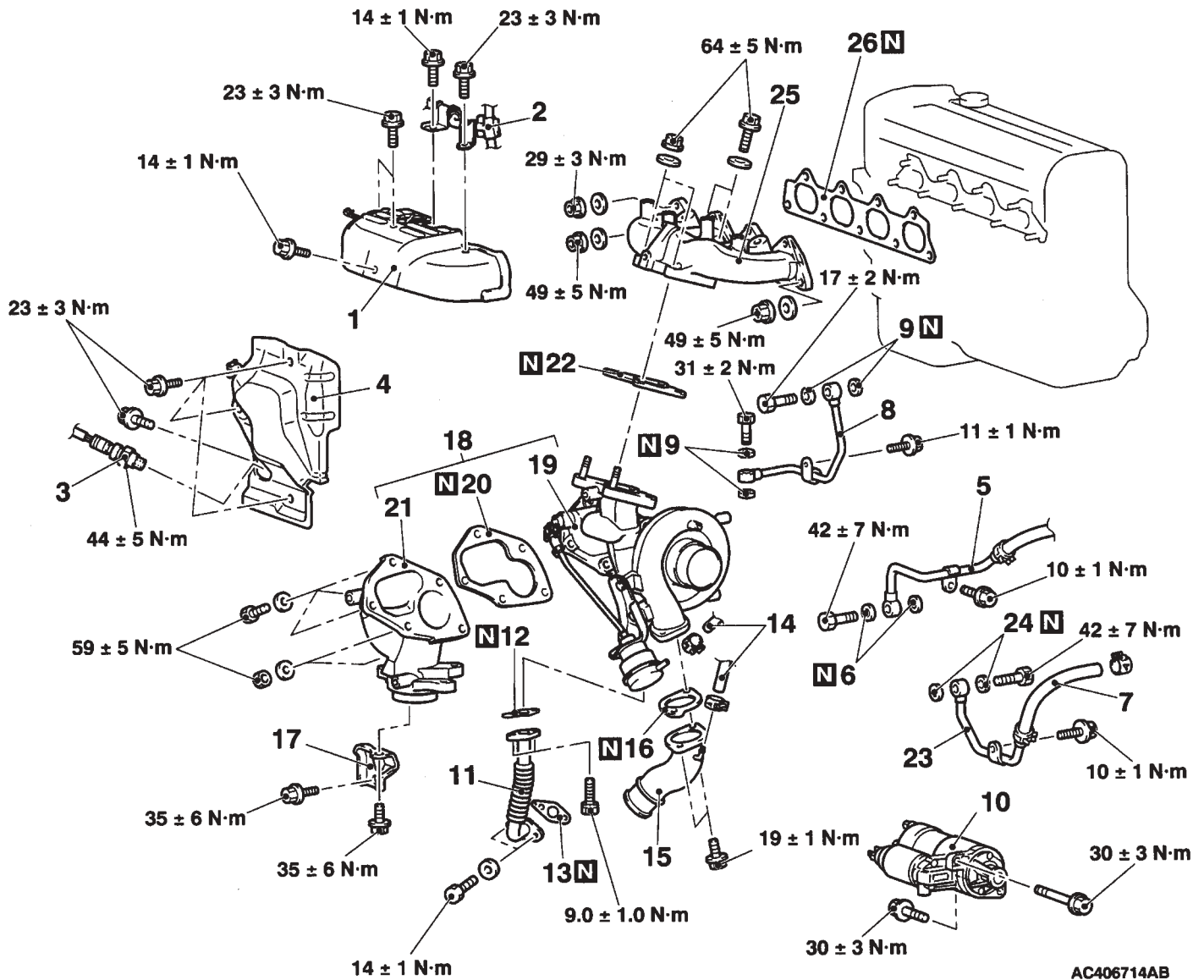

AC406714AB



**Removal procedure**

- 1. Exhaust manifold heat protector
- 2. Air pipe ASSY connection
- ◀ A ▶ 3. O<sub>2</sub> sensor
- 4. Turbocharger heat protector
- 5. Turbocharger water feed pipe connection
- 6. Gasket
- ◀ B ▶ 7. Water hose connection
- 8. Oil feed pipe
- 9. Gasket
- 10. Starter
- ▶ D ◀ 11. Oil return pipe
- ▶ C ◀ 12. Oil return pipe gasket (turbocharger side)
- 13. Oil return pipe gasket (oil pan side)
- 14. Vacuum hose connection
- 15. Air outlet fitting
- ▶ B ◀ 16. Air outlet fitting gasket
- 17. Exhaust fitting bracket
- 18. Turbocharger and exhaust fitting ASSY
- ▶ A ◀ 19. Turbocharger ASSY
- 20. Exhaust fitting gasket
- 21. Exhaust fitting
- 22. Turbocharger gasket
- 23. Turbocharger water return pipe
- 24. Gasket
- 25. Exhaust manifold
- 26. Exhaust manifold gasket

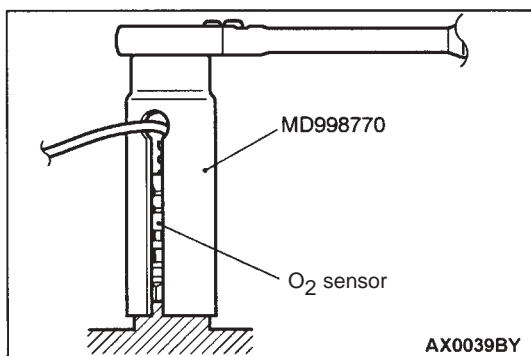

**Removal guidelines**

◀ A ▶ **Removing the O<sub>2</sub> sensor**

After removing the O<sub>2</sub> sensor connector and the clamp, use the special O<sub>2</sub> sensor wrench (MD998770) to remove the O<sub>2</sub> sensor.

◀ B ▶ **Removing the oil feed pipe**

**Caution**

After removing the oil feed pipe, ensure that there is no foreign matter in the oil access hole on the turbocharger.

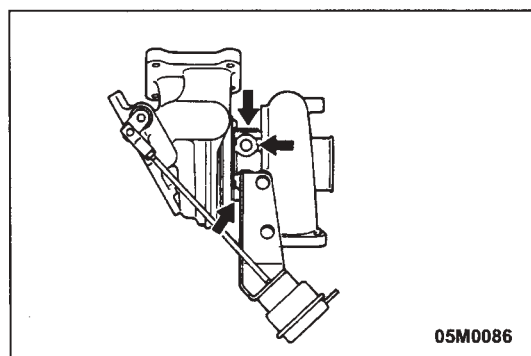

**Fitting guidelines**

▶ A ◀ **Fitting the turbocharger ASSY**

1. Clean away any grease clogging the connection between the oil pipe and the water pipe, and any grease clogging the eyebolts and the inside of the pipes.
2. If there is any carbon in the oil access on the turbocharger ASSY, clean it or blow it away.

**Caution**

Ensure that no foreign matter gets inside the turbocharger ASSY.

3. Apply some fresh engine oil via the fitting hole for the oil feed pipe in the turbocharger ASSY.

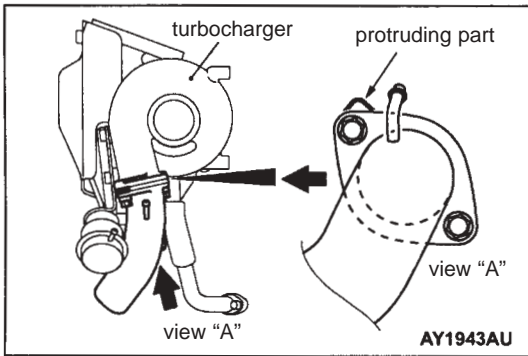

▶ B ◀ **Fitting the air outlet fitting gasket**

Fit the gasket so that the protruding part is in the position located in the diagram.

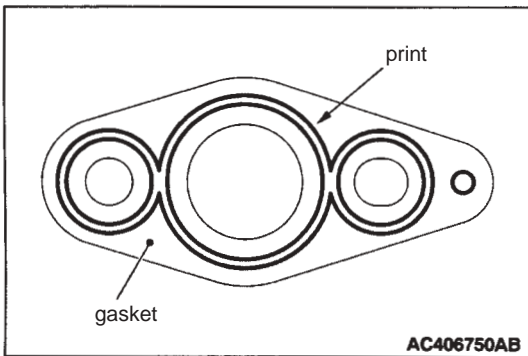

▶ C ◀ **Fitting the oil return pipe gasket (oil pan side)**

Fit so that the printed side of the gasket is on the oil pan side.

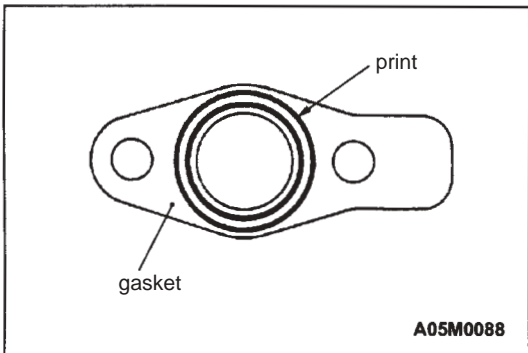

▶ D ◀ **Fitting the oil return pipe gasket (turbocharger side)**

Fit so that the printed side of the gasket is on the turbocharger side.