

GROUP 21A

CLUTCH

CONTENTS

GENERAL DESCRIPTION	21A-2	CLUTCH PEDAL	21A-10
CLUTCH DIAGNOSIS	21A-2	REMOVAL AND INSTALLATION	21A-10
INTRODUCTION TO CLUTCH DIAGNOSIS		INSPECTION.....	21A-11
.....	21A-2	CLUTCH CONTROL	21A-12
CLUTCH DIAGNOSIS TROUBLESHOOTING		REMOVAL AND INSTALLATION	21A-12
STRATEGY.....	21A-2	INSPECTION.....	21A-12
SYMPTOM CHART.....	21A-2	DISASSEMBLY AND ASSEMBLY	21A-13
SYMPTOM PROCEDURES	21A-3	INSPECTION.....	21A-14
ON-VEHICLE SERVICE	21A-7	SPECIFICATIONS	21A-15
CLUTCH PEDAL CHECK AND		FASTENER TIGHTENING	
ADJUSTMENT	21A-7	SPECIFICATIONS.....	21A-15
CLUTCH BLEEDING	21A-8	GENERAL SPECIFICATIONS	21A-15
INTERLOCK SWITCH OPERATING		SERVICE SPECIFICATIONS	21A-15
CHECK	21A-9	LUBRICANTS	21A-15
CLUTCH INTERLOCK SWITCH CHECK AND			
ADJUSTMENT	21A-9		

GENERAL DESCRIPTION

M1211000100159

The clutch is a dry single-disc, diaphragm type; hydraulic pressure is used for the clutch control.

CONSTRUCTION DIAGRAM

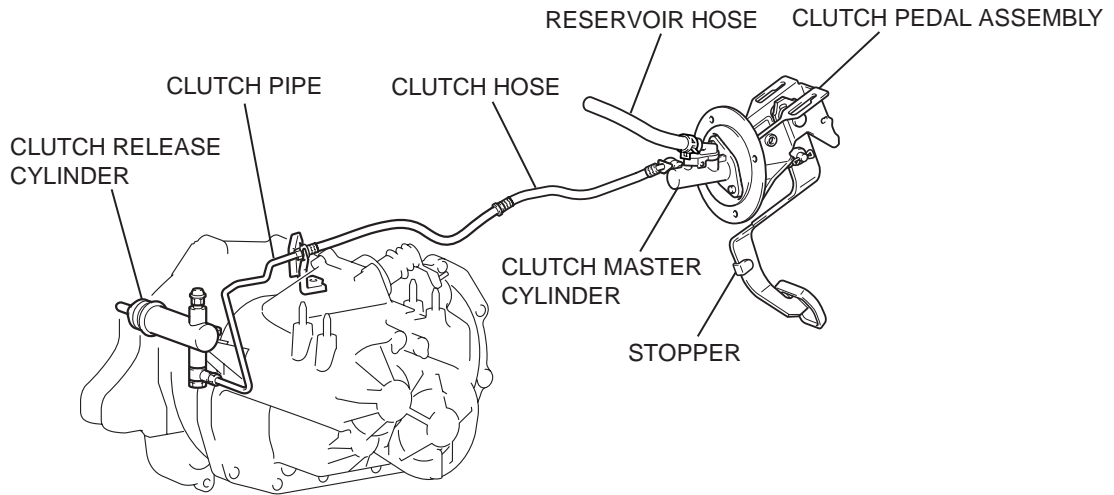

AC211157AB

CLUTCH DIAGNOSIS

INTRODUCTION TO CLUTCH DIAGNOSIS

M1211003400159

A defective clutch causes clutch slippage resulting in poor performance. The causes for this problem may be a faulty clutch line or disc, or a maladjustment of the clutch pedal.

CLUTCH DIAGNOSIS TROUBLESHOOTING STRATEGY

M1211003500156

Use these steps to plan your diagnostic strategy. If you follow them carefully, you will be sure that you have exhausted most of the possible ways to find a clutch fault.

2. Verify that the condition described by the customer exists.
3. Find the malfunction by following the Symptom Chart.
4. Verify malfunction is eliminated.

1. Gather information from the customer.

SYMPTOM CHART

M1211003600131

SYMPTOMS	INSPECTION PROCEDURE	REFERENCE PAGE
Clutch slips	1	P.21A-3
Gear shift malfunction	2	P.21A-4
Clutch noise	3	P.21A-5
Clutch pedal feels "heavy"	4	P.21A-5
When the clutch is engaged, abnormal vibration occurs.	5	P.21A-6

SYMPTOM PROCEDURES

INSPECTION PROCEDURE 1: Clutch Slips

DIAGNOSIS

Step 1. Check insufficient clutch pedal play.

Refer to [P.21A-7](#).

Q: Does the clutch pedal play meet the standard value?

YES : Go to Step 2.

NO : Adjust the clutch pedal play. Then go to Step 7.

Step 2. Check the hydraulic system for clogging.

Refer to [P.21A-12](#).

Q: Is the hydraulic system clogged?

YES : Repair or replace the hydraulic system.
Then go to Step 7.

NO : Go to Step 3.

Step 3. Check the clutch release cylinder for oil leaks or deformation.

Refer to GROUP 21B, Clutch [P.21B-4](#).

Q: Is oil leak or deformation found on clutch release cylinder?

YES : Replace the clutch release cylinder. Then go to Step 7.

NO : Go to Step 4.

Step 4. Check the clutch disc facing for excessive wear.

Refer to GROUP 21B, Clutch [P.21B-4](#).

Q: Is the clutch disc facing worn excessively?

YES : Replace the clutch disc. Then go to Step 7.

NO : Go to Step 5.

Step 5. Check the clutch disc facing for hardening and adhesion of oil.

Q: Is the clutch disc facing hardened or contaminated with oil?

YES : Replace the clutch disc. Then go to Step 7.

NO : Go to Step 6.

Step 6. Check the diaphragm spring for weakness and damage.

Refer to GROUP 21B, Clutch [P.21B-4](#).

Q: Is the diaphragm spring weakened or damaged?

YES : Replace the clutch cover assembly. Then go to Step 7.

NO : Go to Step 7.

Step 7. Check the symptom.

Q: Is the symptom reproduced?

YES : Return to Step 1.

NO : The procedure is complete.

INSPECTION PROCEDURE 2: Gear Shift Malfunction

DIAGNOSIS

Step 1. Check the excessive clutch pedal play.

Refer to [P.21A-7](#).

Q: Does the clutch pedal play meet the standard value?

YES : Go to Step 2.

NO : Adjust the clutch pedal play. Then go to Step 9.

Step 2. Check the hydraulic system for air mix.

Q: Is there a leakage air mix on the hydraulic system?

YES : Bleed the system (Refer to [P.21A-8](#)). Then go to Step 9.

NO : Go to Step 3.

Step 3. Check the hydraulic system for leakage and clogging.

Refer to [P.21A-12](#).

Q: Is there a leakage or clogging on the hydraulic system?

YES : Check the oil line and clutch master cylinder, and repair if necessary. Then go to Step 9.

NO : Go to Step 4.

Step 4. Check the clutch release cylinder for oil leaks or deformation.

Refer to GROUP 21B, Clutch [P.21B-4](#).

Q: Is oil leak or deformation found on clutch release cylinder?

YES : Replace the clutch release cylinder. Then go to Step 9.

NO : Go to Step 5.

Step 5. Check the clutch disc for distortion and wear.

Refer to GROUP 21B, Clutch [P.21B-4](#).

Q: Is the clutch disc distorted or worn?

YES : Replace the clutch disc. Then go to Step 9.

NO : Go to Step 6.

Step 6. Check the clutch disc spline for wear and corrosion.

Refer to GROUP 21B, Clutch [P.21B-4](#).

Q: Is the clutch disc and input shaft spline worn or corroded?

YES : Replace the clutch disc or input shaft. Then go to Step 9.

NO : Go to Step 7.

Step 7. Check the clutch cover assembly for damage.

Refer to GROUP 21B, Clutch [P.21B-4](#).

Q: Is the clutch cover assembly damaged?

YES : Replace the clutch cover assembly. Then go to Step 9.

NO : Go to Step 8.

Step 8. Check the pressure plate and the flywheel for damage.

Q: Is the pressure plate or the flywheel damaged?

YES : Replace the clutch cover assembly or the flywheel. Then go to Step 9.

NO : Go to Step 9.

Step 9. Check the symptom.

Q: Is the symptom reproduced?

YES : Return to Step 1.

NO : The procedure is complete.

INSPECTION PROCEDURE 3: Clutch Noise

DIAGNOSIS

Step 1. Check insufficient clutch pedal play.

Refer to [P.21A-7](#).

Q: Does the clutch pedal play meet the standard value?

YES : Go to Step 2.

NO : Adjust the clutch pedal play. Then go to Step 7.

Step 2. Check the clutch release bearing for wear.

Q: Is the clutch release bearing worn?

YES : Replace the clutch release bearing. Then go to Step 7.

NO : Go to Step 3.

Step 3. Check the bearing sleeve sliding surface for insufficient lubrication.

Q: Is the lubrication of the bearing sleeve sliding surface sufficient?

YES : Go to Step 4.

NO : Repair the bearing sleeve sliding surface. Then go to Step 7.

Step 4. Check the clutch cover assembly for improper installation.

Refer to GROUP 21B, Clutch [P.21B-4](#).

Q: Is the clutch cover assembly installed properly?

YES : Go to Step 5.

NO : Replace the clutch cover assembly. Then go to Step 7.

Step 5. Check the clutch disc facing for excessive wear.

Refer to GROUP 21B, Clutch [P.21B-4](#).

Q: Is the clutch disc facing assembly worn excessively?

YES : Replace the clutch disc assembly. Then go to Step 7.

NO : Go to Step 6.

Step 6. Check the pilot bushing for damage.

Q: Is the pilot bushing damaged?

YES : Replace the pilot bushing. Then go to Step 7.

NO : Go to Step 7.

Step 7. Check the symptom.

Q: Is the symptom reproduced?

YES : Return to Step 1.

NO : The procedure is complete.

INSPECTION PROCEDURE 4: Clutch Pedal Feels "Heavy"

DIAGNOSIS

Step 1. Check the clutch pedal clevis pin for insufficient lubrication.

Q: Is the lubrication of the clutch pedal clevis pin sufficient?

YES : Go to Step 2.

NO : Repair the clutch pedal. Then go to Step 5.

Step 2. Check clutch release cylinder for oil leak or deformation.

Refer to GROUP 21B, Clutch [P.21B-4](#).

Q: Is oil leak or deformation found on clutch release cylinder?

YES : Replace the clutch release cylinder. Then go to Step 5.

NO : Go to Step 3.

Step 3. Check the clutch disc spline for insufficient lubrication.

Refer to GROUP 21B, Clutch [P.21B-4](#).

Q: Is the lubrication of the clutch disc spline sufficient?

YES : Go to Step 4.

NO : Replace the clutch disc. Then go to Step 5.

Step 4. Check the insufficient lubrication of bearing sleeve sliding surface.

Q: Is the lubrication of the bearing sleeve sliding surface sufficient?
YES : Go to Step 5.
NO : Repair the bearing sleeve sliding surface.
 Then go to Step 5.

Step 5. Check the symptom.

Q: Is the symptom reproduced?
YES : Return to Step 1.
NO : The procedure is complete.

INSPECTION PROCEDURE 5: When the clutch is engaged, abnormal vibration occurs.

DIAGNOSIS

Step 1. Check the engine and transaxle mounting for loosening and damage.

Q: Is the engine and transaxle mounting loosened or damaged?
YES : Tighten or replace the engine and transaxle mounting. Then go to Step 7.
NO : Go to Step 2.

Step 2. Check clutch release cylinder for oil leaks or deformation.

Refer to GROUP 21B, Clutch [P.21B-4](#).

Q: Is oil leak or deformation found on the clutch release cylinder?
YES : Replace the clutch release cylinder. Then go to Step 3.
NO : Go to Step 3.

Step 3. Check the diaphragm spring for uneven height.

Q: Is the diaphragm spring even height?
YES : Go to Step 4.
NO : Replace the clutch cover assembly. Then go to Step 4.

Step 4. Check the pressure plate and flywheel for damage.

Q: Is the pressure plate or flywheel damaged?
YES : Repair the clutch cover assembly or flywheel. Then go to Step 5.
NO : Go to Step 5.

Step 5. Check the clutch disc facing for wear and damage.

Refer to GROUP 21B, Clutch [P.21B-4](#).

Q: Is the clutch disc facing worn or damaged?
YES : Replace the clutch disc. Then go to Step 7.
NO : Go to Step 6.

Step 6. Check for grease or oil on the clutch disc facing.

Refer to GROUP 21B, Clutch [P.21B-4](#).

Q: Is there grease or oil on the clutch disc facing?
YES : If the clutch disc facing is contaminated with grease or oil, check that greases is applied to the clutch disc spline (Refer to GROUP 21B, Clutch [P.21B-4](#)). Then check the clutch housing input shaft oil seal (Refer to GROUP 22B, Clutch Housing [P.21B-2](#)) and the crank shaft rear oil seal (Refer to GROUP 11A, Crankshaft Oil Seal [P.11A-41](#)) for leakage, and replace the oil seal(s).
 Replace the clutch disc. Then go to Step 7.
NO : Go to Step 7.

Step 7. Check the symptom.

Q: Is the symptom reproduced?
YES : Return to Step 1.
NO : The procedure is complete.

ON-VEHICLE SERVICE

CLUTCH PEDAL CHECK AND ADJUSTMENT

M1211000900177

1. Turn up the carpet etc. under the clutch pedal.
2. Measure the clutch pedal height.

Standard value (A): 202.1 – 206.1 mm (7.96 – 8.11 inch)

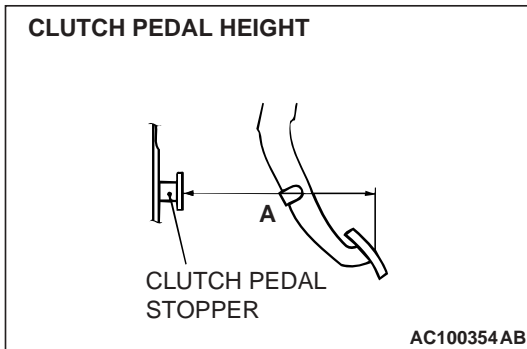

CAUTION

Do not push in the master cylinder pushrod at this time, otherwise the clutch will not operate properly.

3. If the height of the clutch pedal is outside the standard value, loosen the setting nut to adjust the pedal height to the standard value.

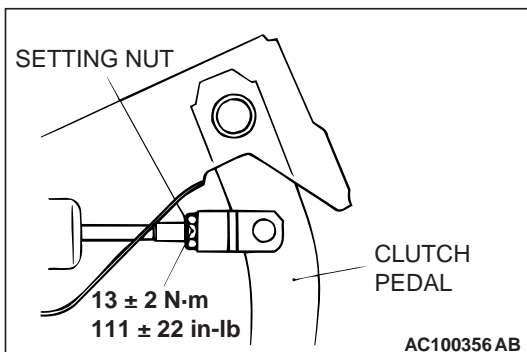

4. Measure the clutch pedal clevis pin play.

Standard value (B): 1 – 3 mm (0.04 – 0.12 inch)

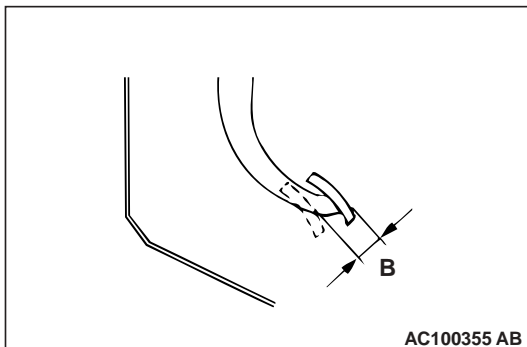

CAUTION

Do not push in the master cylinder pushrod at this time, otherwise the clutch will not operate properly.

5. If the clutch pedal clevis pin play is not within the standard value, loosen the setting nut to adjust the clutch pedal clevis pin play to the standard value.

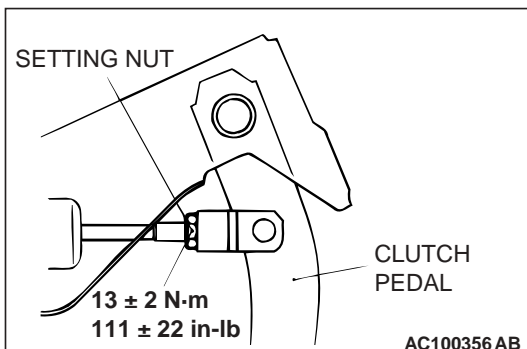

CLUTCH PEDAL FREE PLAY

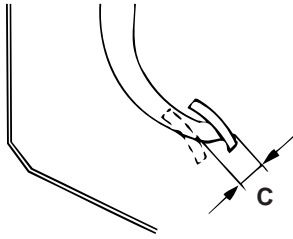

AC100355 AC

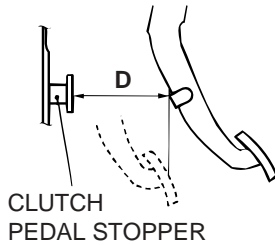
CLUTCH
PEDAL STOPPER

AC100357 AB

- After completing the adjustments, confirm that the clutch pedal free play (measured at the face of the pedal pad) and the distance between the clutch pedal (the face of the pedal pad) and the clutch pedal stopper when the clutch is disengaged are within the standard value ranges.

Standard value (C): 4 – 13 mm (0.16 – 0.51 inch)

Standard value (D): 114.3 mm (4.5 inches) or more

- If the clutch pedal free play and the distance between the clutch pedal and the clutch pedal stopper when the clutch is disengaged do not agree with the standard values, it is probably the result of either air in the hydraulic system or a faulty master cylinder, clutch cylinder or clutch. Bleed the air, or disassemble and inspect the master cylinder, clutch cylinder or clutch.
- Turn back the carpet, etc.

CLUTCH BLEEDING

M1211001400153

⚠ CAUTION

Use the specified brake fluid. Do not mix brake fluids.

Specified fluid: Brake fluid DOT 3 or DOT 4

- Connect a hose with a bottle to the bleeder screw.
- Open the bleed nipple.

⚠ CAUTION

For bleeding, never "pump" the clutch pedal. This may cause an oil leak at the clutch cylinder.

- Depress the clutch pedal slowly. Open the bleeder screw to let air and brake fluid out. Close the bleeder screw. Release the clutch pedal. Repeat until only brake fluid and no air comes out.
- Check that the brake fluid reservoir level stays between "MAX" and "MIN" marks throughout the clutch bleeding process.

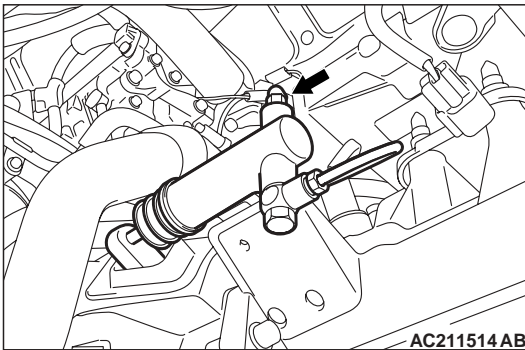

AC211514 AB

INTERLOCK SWITCH OPERATING CHECK

M1211001000155

1. Lock the front wheels, apply the parking brake.
2. After normally adjusting the clutch pedal, check the interlock switch operation as follows:
 - (1) The engine should not start even if the ignition switch is turned to the "START" position with the clutch pedal released. If the engine should start, check the interlock switch and the harness.
 - (2) The engine should start after the clutch pedal is depressed and the ignition switch turned to the "START" position. If the engine should start before the clutch is disengaged or the engine does not start even if the clutch pedal is depressed, check and adjust the interlock switch.

CLUTCH INTERLOCK SWITCH CHECK AND ADJUSTMENT

M1211001100152

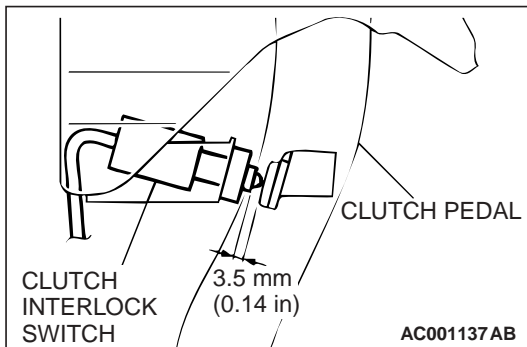

1. Check to be sure that the interlock switch is as shown in the illustration when the clutch pedal is depressed at its full stroke 149.9 mm (5.90 inches). If not at the specified dimension, loosen the clutch interlock switch 1/4 turn counterclockwise. Then slide the switch to the specified dimension, and turn the switch 1/4 turn clockwise to lock.

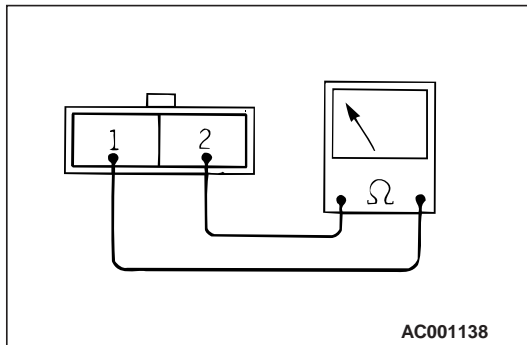

2. Connect an ohmmeter to the interlock switch connector, and then check for continuity when the clutch pedal is fully depressed and when it is released outward.

TESTER CONNECTION	PEDAL POSITION	SPECIFIED CONDITION
1-2	FULLY DEPRESSED	Open circuit
	RELEASED	Less than 2 ohms

3. If the interlock switch is not as it should be, replace it.

CLUTCH PEDAL

REMOVAL AND INSTALLATION

M1211001600168

Post-installation Operation

- Clutch Pedal Adjustment (Refer to P.21A-7.)
- Clutch Interlock Switch Adjustment (Refer to P.21A-9.)
- Clutch Pedal Position Switch Adjustment (Refer to P.21A-9.)

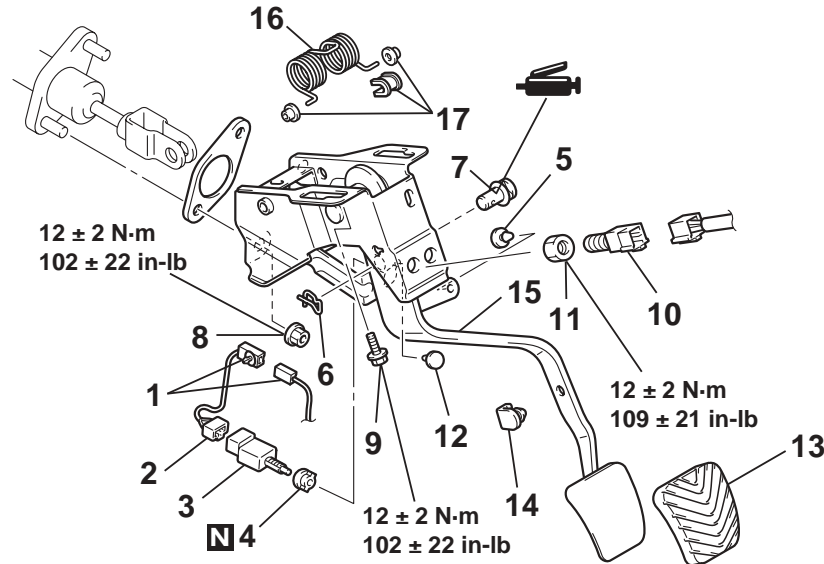

AC211161AB

REMOVAL STEPS

- INSTRUMENT PANEL UNDER COVER (REFER TO GROUP 52A, INSTRUMENT PANEL P.52A-3.)
1. CLUTCH INTERLOCK SWITCH SUB-HARNESS CONNECTION
 2. CLUTCH INTERLOCK SWITCH SUB-HARNESS
 3. CLUTCH INTERLOCK SWITCH
 4. CLIP
 5. STOPPER
 6. SNAP PIN
 7. CLEVIS PIN

REMOVAL STEPS (Continued)

8. CLUTCH MASTER CYLINDER MOUNTING NUT
9. CLUTCH PEDAL ASSEMBLY MOUNTING BOLT
10. CLUTCH PEDAL POSITION SWITCH
11. NUT
12. STOPPER
13. PEDAL PAD
14. PEDAL STOPPER
15. CLUTCH PEDAL ASSEMBLY
16. TURN OVER SPRING
17. BUSHING

INSPECTION

M1211001700132

CLUTCH PEDAL POSITION SWITCH CHECK

1. Connect an ohmmeter between the clutch pedal position switch connector terminals.
2. There should be no continuity between the terminals when the plunger is pushed in as shown. There should be continuity when it is released.

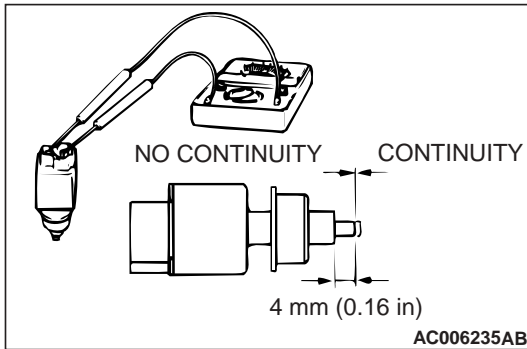

CLUTCH INTERLOCK SWITCH CHECK

1. Connect an ohmmeter between the clutch interlock switch connector terminals.
2. There should be no continuity between the terminals when the plunger is pushed in as shown. There should be continuity when it is released.

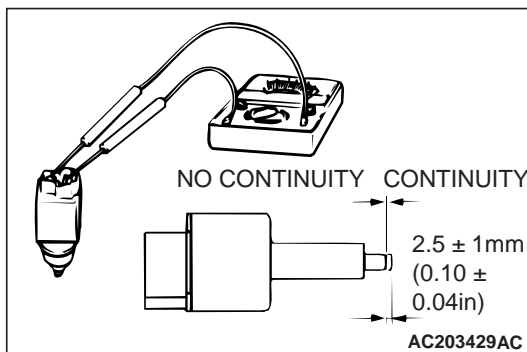

CLUTCH CONTROL

REMOVAL AND INSTALLATION

M1211001900170

Pre-removal Operation

Clutch Fluid Draining

Post-installation Operation

- Clutch Fluid Supplying
- Clutch Line Bleeding (Refer to P.21A-8.)
- Clutch Pedal Adjustment (Refer to P.21A-7.)

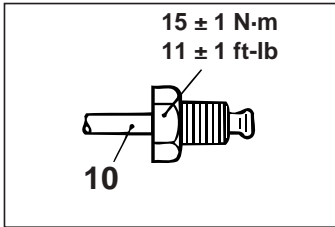
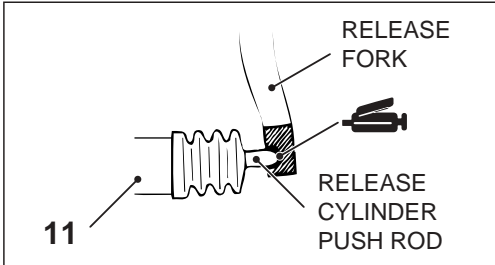

SPECIFIED GREASE:
MITSUBISHI GENUINE GREASE
PART NO. 0101011

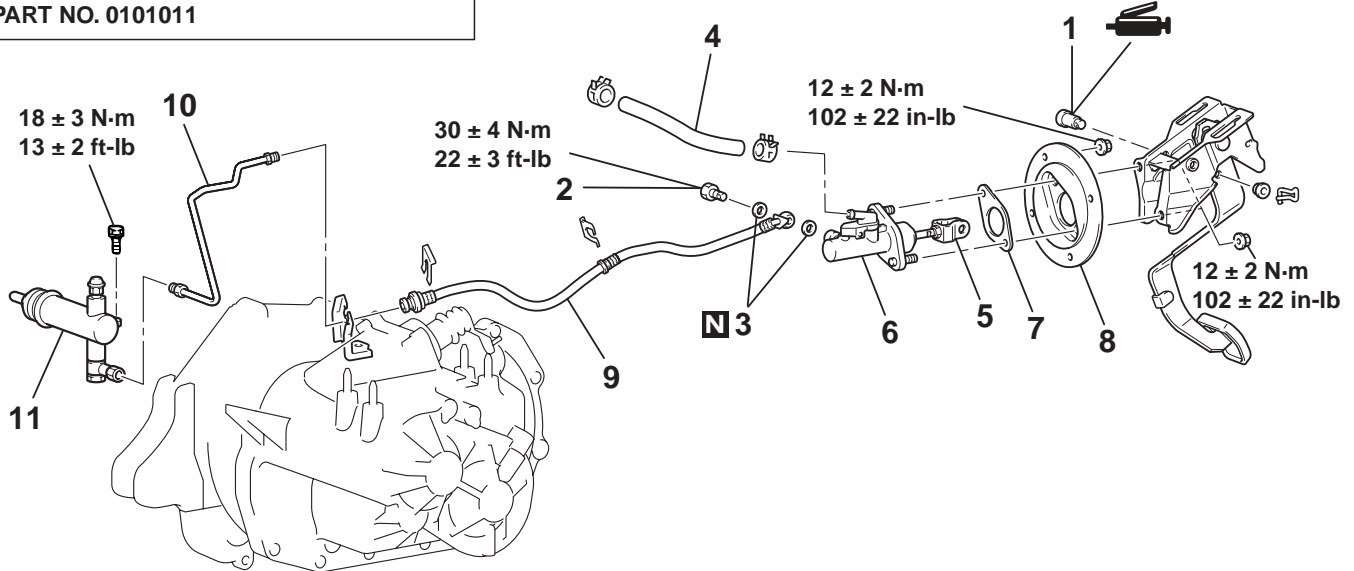

Y2285AUAB

CLUTCH MASTER CYLINDER REMOVAL STEPS

1. CLEVIS PIN ASSEMBLY
2. EYE BOLT
3. GASKET
4. RESERVOIR HOSE
5. CLEVIS PIN AND PUSHROD ASSEMBLY CONNECTING PART
6. CLUTCH MASTER CYLINDER

7. SEALER
 8. RETAINER PLATE
- CLUTCH RELEASE CYLINDER REMOVAL STEPS**

10. CLUTCH PIPE
 11. CLUTCH RELEASE CYLINDER
- CLUTCH LINE REMOVAL STEPS**
9. CLUTCH HOSE
 10. CLUTCH PIPE

INSPECTION

M1211002000125

- Check the master cylinder or clutch hose for fluid leakage.
- Check the clutch hose or tube for cracks or clogging.

DISASSEMBLY AND ASSEMBLY

CLUTCH MASTER CYLINDER

CAUTION

Do not disassemble the piston assembly.

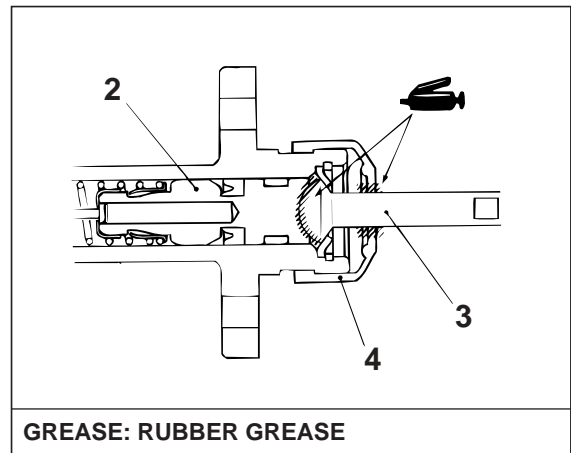
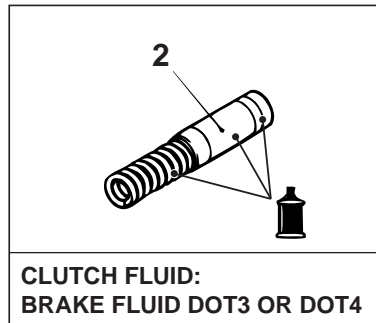
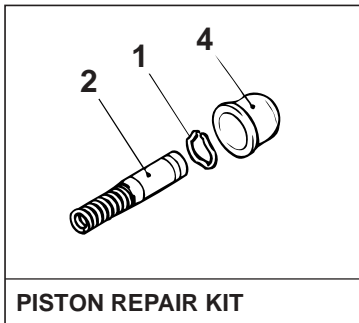
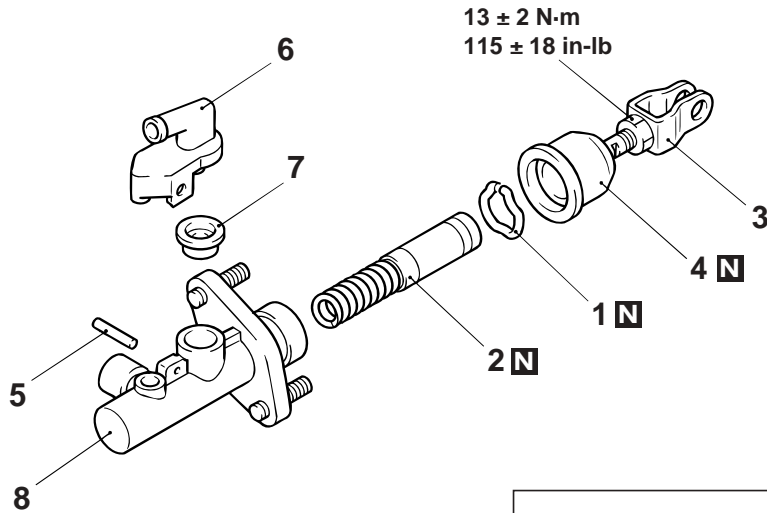

AC100362AD

DISASSEMBLY STEPS

- >>A<<
1. PISTON STOPPER RING
 2. PISTON ASSEMBLY
 3. PUSHROD ASSEMBLY
 4. BOOT

DISASSEMBLY STEPS

5. SPRING PIN
6. NIPPLE
7. SEAL
8. MASTER CYLINDER BODY

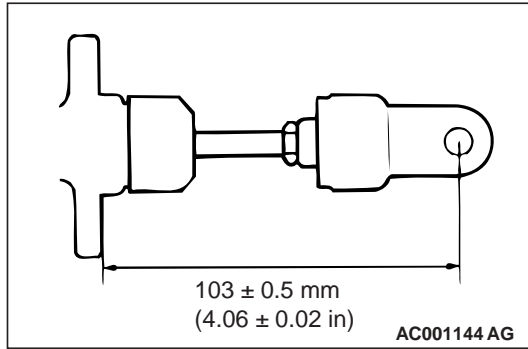
ASSEMBLY SERVICE POINT**>>A<< PUSHROD ASSEMBLY INSTALLATION**

Set the length of the pushrod assembly to the dimension shown to make the adjustment of the clutch pedal easier.

INSPECTION

M1211002200129

- Check inside the cylinder body for rust and scars.
- Check the piston cup for wear and deformation.
- Check the piston for rust and scars.
- Check the pipe connection for clogging.

SPECIFICATIONS

FASTENER TIGHTENING SPECIFICATIONS

M1211003300152

ITEM		SPECIFICATION
Clutch control	Clutch release cylinder mounting bolt	18 ± 3 N·m (13 ± 2 ft-lb)
	Clutch master cylinder mounting nut	12 ± 2 N·m (102 ± 22 in-lb)
	Clutch pipe flare nut	15 ± 1 N·m (11 ± 1 ft-lb)
	Eye bolt	30 ± 4 N·m (22 ± 3 ft-lb)
	Pushrod jam nut	13 ± 2 N·m (111 ± 22 in-lb)
	Retainer assembly nut	12 ± 2 N·m (102 ± 22 in-lb)
Clutch pedal	Clutch master cylinder mounting nut	12 ± 2 N·m (102 ± 22 in-lb)
	Clutch pedal assembly mounting bolt	12 ± 2 N·m (102 ± 22 in-lb)
	Clutch pedal position switch setting nut	12 ± 2 N·m (109 ± 21 in-lb)

GENERAL SPECIFICATIONS

M1211000200145

ITEM	SPECIFICATION
Clutch release cylinder I.D. mm (in)	20.64 (0.81)
Clutch master cylinder I.D. mm (in)	15.87 (5/8)

SERVICE SPECIFICATIONS

M1211000300153

ITEM	STANDARD VALUE
Clutch pedal height mm (in)	202.1 – 206.1 (7.96 – 8.11)
Clutch pedal clevis pin play mm (in)	1 – 3 (0.04 – 0.12)
Clutch pedal free play mm (in)	4 – 13 (0.16 – 0.51)
Distance between the clutch pedal and the toeboard when the clutch pedal is released mm (in)	114.3 (4.5) or more

LUBRICANTS

M1211000400149

ITEM	SPECIFIED LUBRICANT	QUANTITY
Clutch fluid	Brake Fluid DOT 3 or DOT 4	As required
Pushrod assembly	Rubber grease	As required
Boot	Rubber grease	As required
Release cylinder push rod	MITSUBISHI genuine grease Part No.0101011	As required

NOTES