

GROUP 12

ENGINE LUBRICATION

CONTENTS

GENERAL DESCRIPTION	12-2	ENGINE OIL COOLER	12-6
SPECIAL TOOL	12-2	REMOVAL AND INSTALLATION	12-6
ON-VEHICLE SERVICE	12-3	SPECIFICATIONS	12-7
ENGINE OIL CHECK	12-3	FASTENER TIGHTENING	
ENGINE OIL REPLACEMENT	12-3	SPECIFICATIONS.....	12-7
ENGINE OIL FILTER REPLACEMENT ...	12-4	SERVICE SPECIFICATIONS	12-7
OIL PRESSURE CHECK	12-4	SEALANT	12-7
		LUBRICANTS	12-7

GENERAL DESCRIPTION

M1121000100324

The lubrication method is a fully force-fed, full-flow filtration type.

ITEM	SPECIFICATION
Oil pump type	Involute gear type
Drive method	Timing belt

ENGINE OILS**⚠ WARNING**

Prolonged and repeated contact with mineral oil will result in the removal of natural fats from the skin, leading to dryness, irritation and dermatitis. In addition, used engine oil contains potentially harmful contaminants which may cause skin cancer. Adequate means of skin protection and washing facilities must be provided.

Recommended Precautions

The most effective precaution is to adapt working practices which prevent, as far as practical, the risk of skin contact with mineral oils, i.e. use enclosed systems for handling used engine oil and decrease components, where practical, before handling them.

Other precautions:

- Avoid prolonged and repeated contact with oil, particularly used engine oil.
- Wear protective clothing, including impervious gloves where practical.
- Avoid contaminating clothes, particularly underwear with oil.
- Do not put oily rags in pockets.
- Do not wear heavily soiled clothing and oil-soaked foot-wear. Overalls must be cleaned regularly and kept separate from personal clothing.

- Where there is a risk of eye contact, eye protection should be worn, i.e. chemical goggles or face shields. In addition, an eye wash facility should be provided.
- Obtain First Aid treatment immediately for open cuts and wounds.
- Wash regularly with soap and water to ensure all oil is removed, especially before meals (skin cleansers and nail brushes will help). After cleaning, apply lotion, etc., containing lanolin to replace natural skin oils.
- Do not use gasoline, kerosene, diesel fuel, gas oil, thinners or solvents for cleaning skin.
- Apply barrier creams before each work period to help clean the skin after work.
- If skin disorders develop, obtain medical advice immediately.

SPECIAL TOOL

M1121000600352

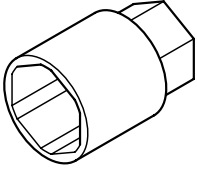
TOOL	TOOL NUMBER AND NAME	SUPERSESSON	APPLICATION
	MD998054 Oil pressure switch wrench	General service tool or MD998054-01	Removal and installation of oil pressure switch

ON-VEHICLE SERVICE

ENGINE OIL CHECK

M1121000900308

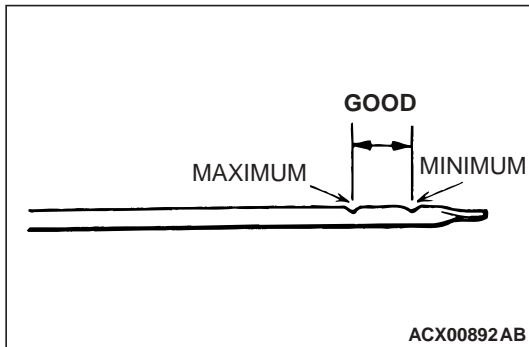

1. Pull out the oil dipstick slowly and check that the oil level is within the marks on the oil dipstick.
2. Check that the oil is not excessively dirty, that there is no coolant or gasoline mixed in, and that it is sufficiently thick and slippery.

ENGINE OIL REPLACEMENT

M1121001000364

1. Start the engine and allow it to warm up until the temperature of the coolant reaches 80°C (176°F) to 90°C (194°F).

⚠ WARNING

Use care as oil could be hot.

2. Remove the engine oil filler cap.
3. Remove the drain plug to drain oil.
4. Install a new drain plug gasket so that it faces in the direction shown in the illustration, and then tighten the drain plug to the specified torque.

Tightening torque: 39 ± 5 N·m (29 ± 3 ft·lb)

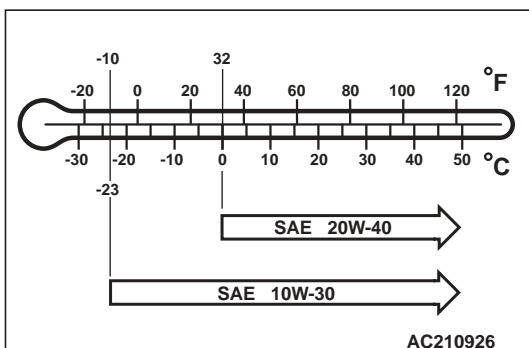
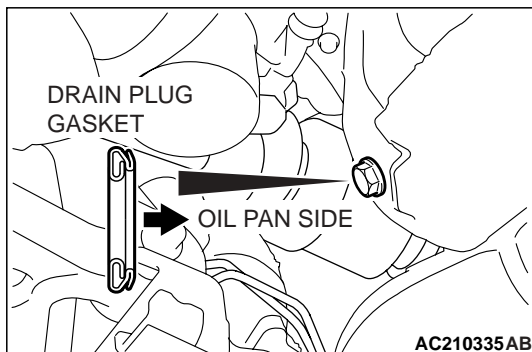

⚠ CAUTION

- Do not use conventional petroleum based motor oil. Using conventional motor oil may cause engine or turbocharger damage.
 - Do not use "blends" of conventional oil and synthetic oil.
5. Refill the specified quantity of oil.
 - Specified Engine Oil: Fully synthetic engine oils displaying ILSAC GF-3 certification symbol ("Starburst" symbol) or conforming to the API classification SL or SL/CF
 - Total quantity (Includes volume inside oil filter and oil cooler): 5.1 dm³ (5.4 quarts)

NOTE: SAE 5W-30 fully synthetic engine oil can be used to improve engine start ability in very cold weather areas where the lowest atmospheric temperature is below -23°C (-10°F).

6. Install the engine oil filler cap.
7. Check oil level.

ENGINE OIL FILTER REPLACEMENT

M1121001100338

1. Start the engine and allow it to warm up until the temperature of the coolant reaches 80°C (176°F) to 90°C (194°F).

⚠ WARNING**Use care as oil could be hot.**

2. Remove the engine oil filler cap.
3. Remove the drain plug to drain oil.
4. Remove the side cover.
5. Use the commercially-available tool to remove the engine oil filter.
6. Clean the filter bracket side mounting surface and ensure the old O-ring has been removed.

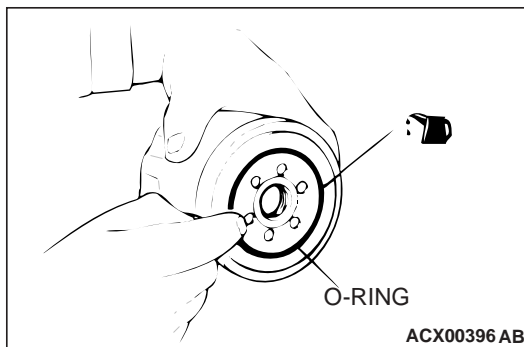
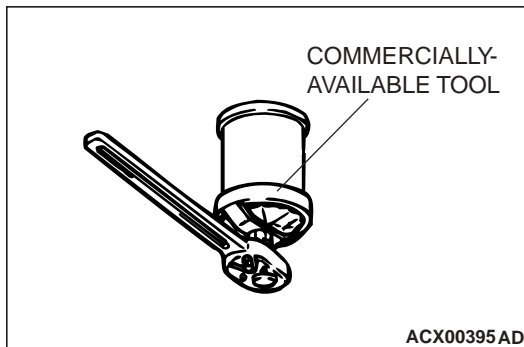

7. Apply a small amount of engine oil to the O-ring of the new oil filter.
8. Where the oil filter O-ring touches the oil pan flange, tighten the oil filter to the specified torque using the commercially-available tool.

Tightening torque: Approximately 3/4 turn [14 ± 2 N·m (124 ± 18 in-lb)]

9. Install the side cover.
10. Install the drain plug and refill engine oil. (Refer to Engine Oil Replacement P.12-3.)
11. Rev the engine a few times, and check to be sure that no engine oil leaks from the installation section of the oil filter.

OIL PRESSURE CHECK

M1121002300324

Required Special Tool:

- MD998054: Oil Pressure Switch Wrench

1. Check engine oil quantity.
2. Remove the oil pressure switch terminal.

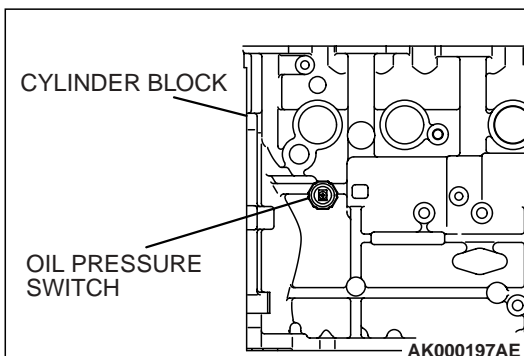

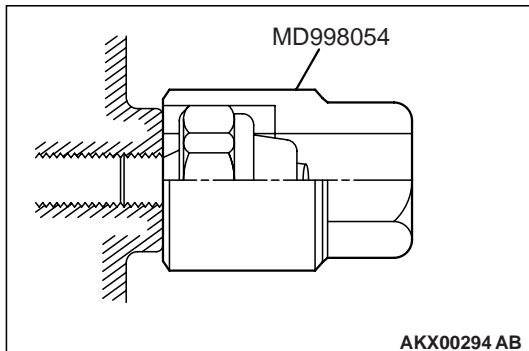

CAUTION

Since sealant is applied to the thread of the oil pressure switch and may be difficult to unscrew, take care not to damage the oil pressure switch when removing it.

3. Use special tool MD998054 to remove the oil pressure switch.
 4. Install the oil pressure gauge.
- NOTE: Use a 1/8 pipe thread adapter.*
5. Run the engine to warm it.
 6. After the engine has warmed up, check that oil pressure is within the standard value.

Standard value:

At idle: 29 kPa (4.2 psi) or more

At 3,500 r/min: 294 – 686 kPa (43 – 100 psi)

7. Remove the oil pressure gauge.
8. Apply the specified sealant 3M™ AAD Part number 8672 or equivalent to thread of the oil pressure switch.

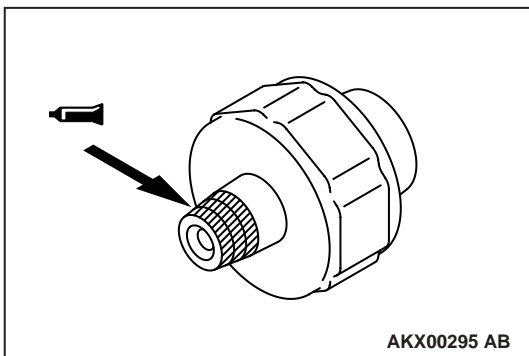

CAUTION

Do not start the engine within one hour after the engine oil pressure switch has been installed to allow sufficient drying time for the sealant.

9. Use special tool MD998054 to tighten the oil pressure switch to the specified torque.

Tightening torque: 18 ± 3 N·m (160 ± 30 in-lb)

10. Install the oil pressure switch terminal.

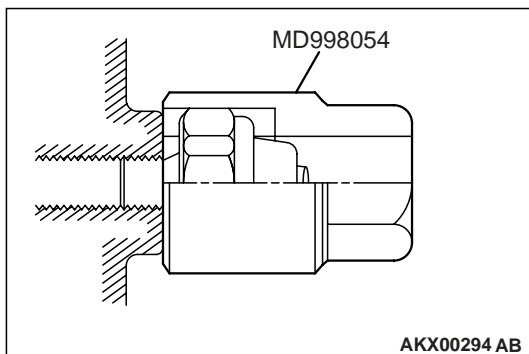

ENGINE OIL COOLER

REMOVAL AND INSTALLATION

M1121001300097

CAUTION

If the vehicle is equipped with the Brembo™ disc brake, during maintenance, take care not to contact the parts or tools to the caliper because the paint of caliper will be scratched.

Pre-removal Operation

- Engine Oil Draining (Refer to P.12-3.)
- Under Cover Removal (Refer to GROUP 51, Front Bumper P.51-2.)
- Side Cover Removal

Post-installation Operation

- Side Cover Installation
- Under Cover Installation (Refer to GROUP 51, Front Bumper P.51-2.)
- Engine Oil Refilling (Refer to P.12-3.)

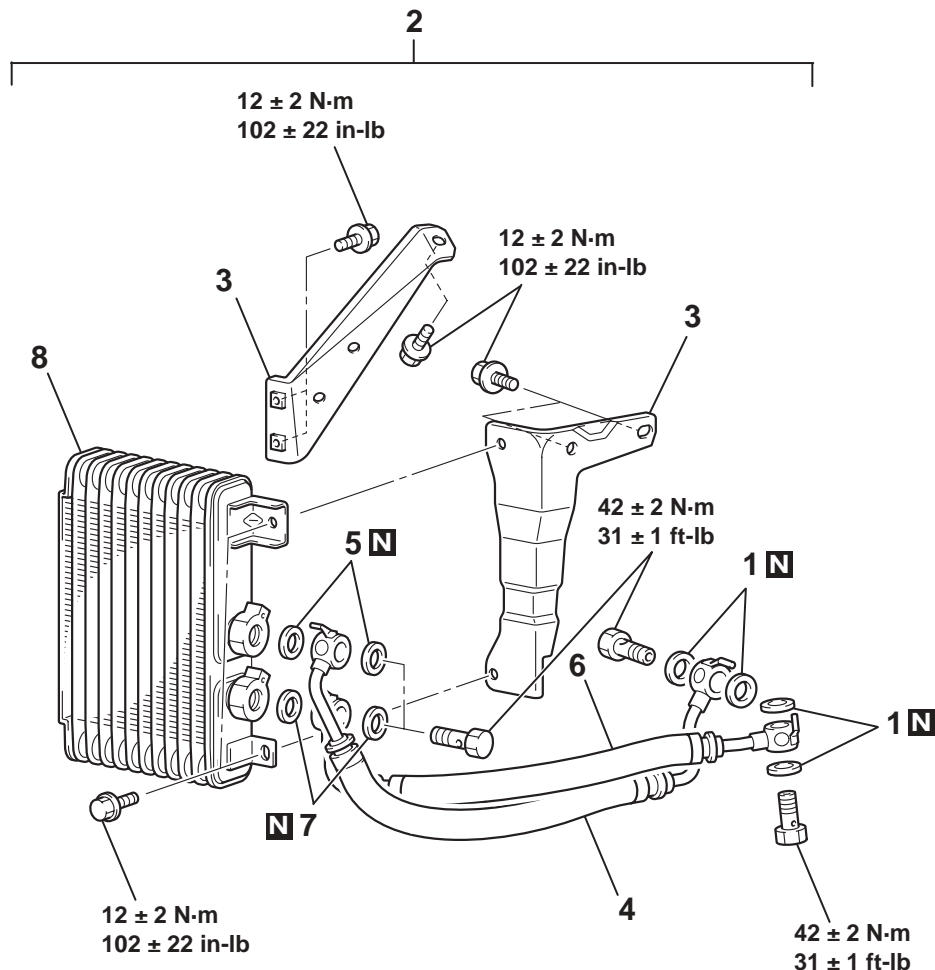
**REMOVAL STEPS**

1. ENGINE OIL COOLER TUBE GASKETS
2. ENGINE OIL COOLER, BRACKET AND HOSE ASSEMBLY
3. ENGINE OIL COOLER BRACKETS
4. ENGINE OIL COOLER FEED HOSE

REMOVAL STEPS (Continued)

5. ENGINE OIL COOLER TUBE GASKETS
6. ENGINE OIL COOLER RETURN HOSE
7. ENGINE OIL COOLER TUBE GASKETS
8. ENGINE OIL COOLER

SPECIFICATIONS

FASTENER TIGHTENING SPECIFICATIONS

M1121002200264

ITEM	SPECIFICATION
Engine oil cooler bolt	12 ± 2 N·m (102 ± 22 in-lb)
Engine oil cooler bracket bolt	12 ± 2 N·m (102 ± 22 in-lb)
Engine oil cooler line eye bolt	42 ± 2 N·m (31 ± 1 ft-lb)
Engine oil filter	14 ± 2 N·m (124 ± 18 in-lb)
Engine oil pan drain plug	39 ± 5 N·m (29 ± 3 ft-lb)

SERVICE SPECIFICATIONS

M1121000300102

ITEM	STANDARD VALUE
Oil pressure kPa (psi)	at idle 29 (4.2) or more
	at 3,500 r/min 294 – 686 (43 – 100)

SEALANT

M1121000500098

ITEM	SPECIFIED SEALANT
Oil pressure switch	3M™ AAD Part No. 8672 or equivalent

LUBRICANTS

M1121000400381

ITEM	ENGINE OIL	QUANTITY dm ³ (qt)
Oil filter	Fully synthetic engine oils displaying ILSAC GF-3 certification symbol ("Starburst" symbol) or conforming to the API classification SL or SL/CF	0.3 (0.32)
Oil cooler		0.3 (0.32)
Total quantity		5.1 (5.4)

ENGINE OIL

⚠ CAUTION

Never use nondetergent or straight mineral oil.

Use only engine oils displaying the ILSAC certification mark ("Starburst" symbol) on the container.

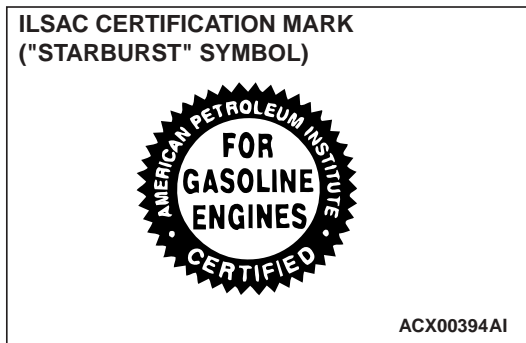

API SERVICE SYMBOL



AC210927AB

If these oils are not available, an API classification SL or SL/CF can be used.