

GROUP 54B

SIMPLIFIED WIRING SYSTEM (SWS)

CONTENTS

GENERAL INFORMATION	54B-2	DIAGNOSTIC TROUBLE CODE SET	54B-5
COMMUNICATION METHOD	54B-2	TONE ALARM.....	54B-6
MULTI-DISTRIBUTION INPUT/OUTPUT BY CIRCUIT	54B-3		

GENERAL INFORMATION

M2541000100167

SWS is a minimal line system which transmits numerous signals using one wiring system.

NOTE: *: ETACS (Electronic Time and Alarm Control System)

To transmit numerous signals, the ETACS*-ECU, column switch and front-ECU incorporate multi-distribution circuits to carry out communication between control units.

CONSTRUCTION DIAGRAM

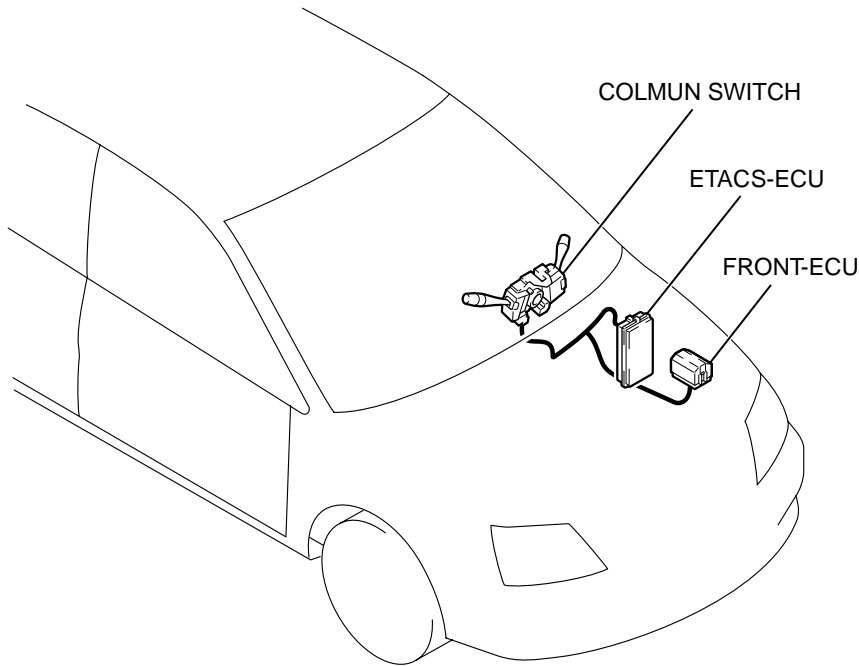

AC210681AB

COMMUNICATION METHOD

M2541001000130

The exclusive signal lines for transmitting the multi-distribution data are connected as shown between the ETACS-ECU, column switch (incorporated inside the column ECU) and front-ECU for internal communication.

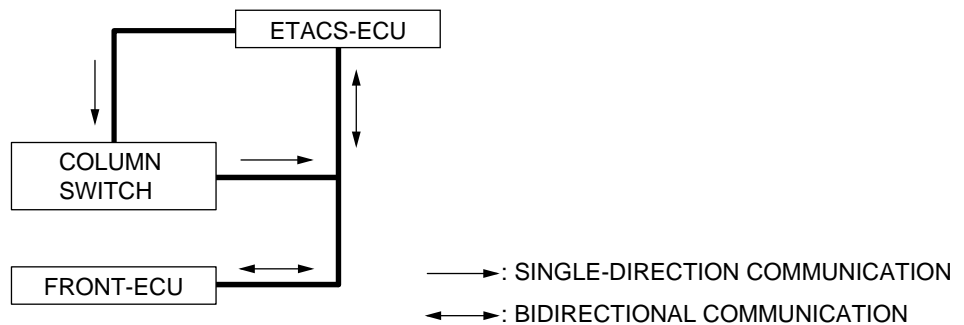

AC210115AB

MULTI-DISTRIBUTION INPUT/OUTPUT BY CIRCUIT

M2541002000144

Multi-distribution is employed by the following circuits. The relation of the input switches, sensors, ECUs connected by multi-distribution lines, and outputs are also shown below.

TONE ALARM

- Light still ON reminder warning function

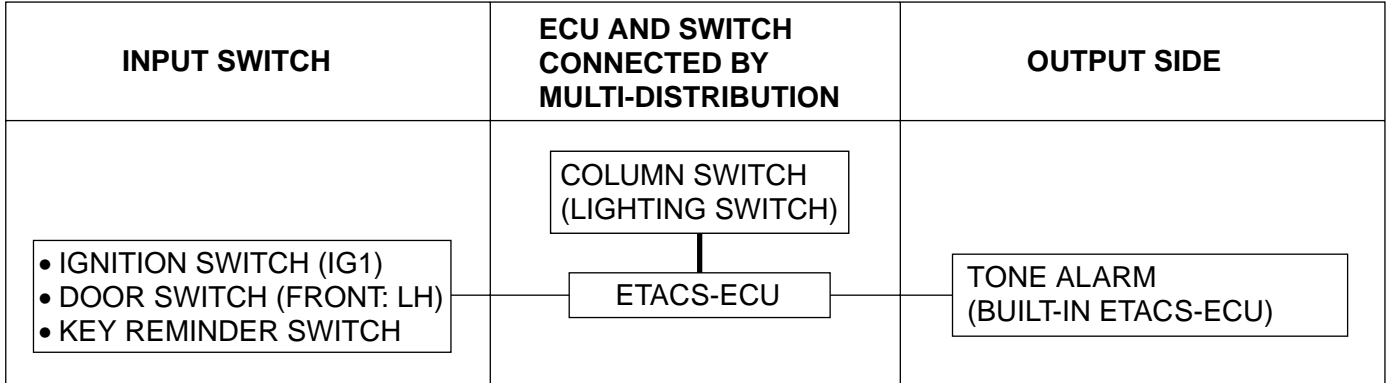

AC210161AB

WINDSHIELD WIPER AND WASHER

- | | |
|---|--|
| <ul style="list-style-type: none"> • Windshield mist wiper • Vehicle speed-dependent variable windshield intermittent wiper | <ul style="list-style-type: none"> • Windshield low speed wiper • Windshield high speed wiper • Windshield washer |
|---|--|

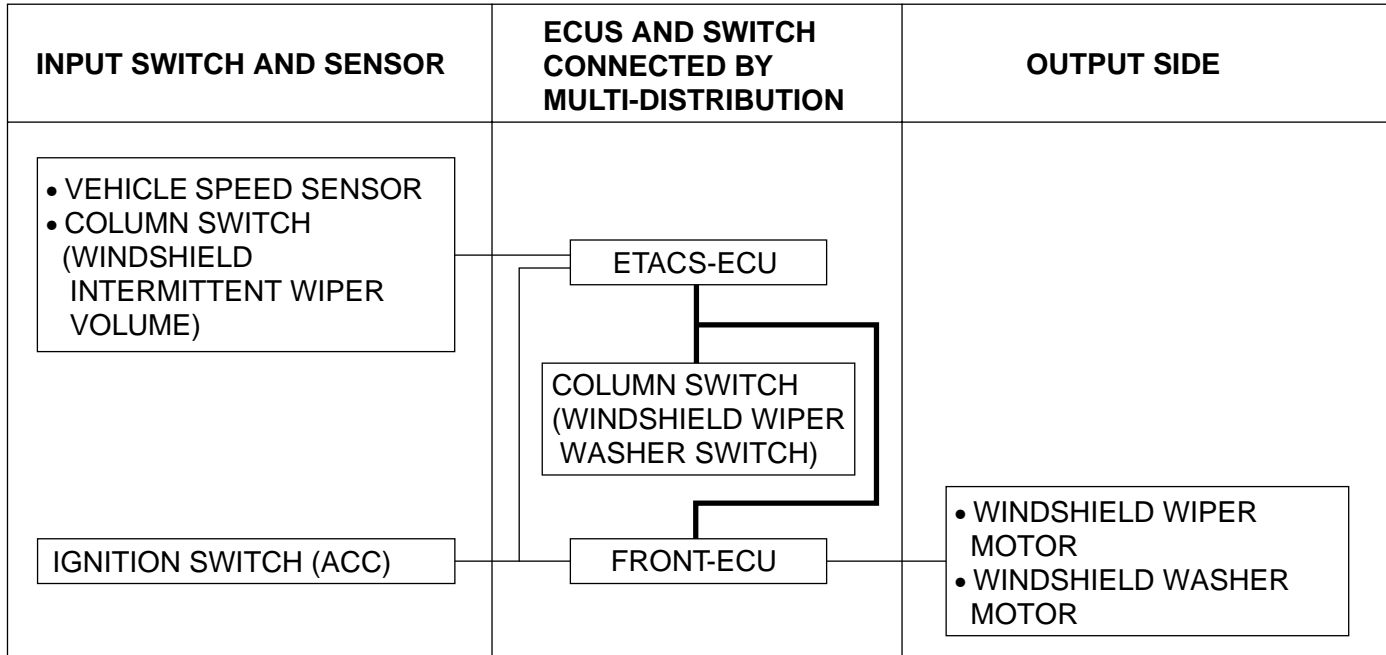

AC210162AB

REAR WIPER AND WASHER

- Rear wiper
- Rear washer

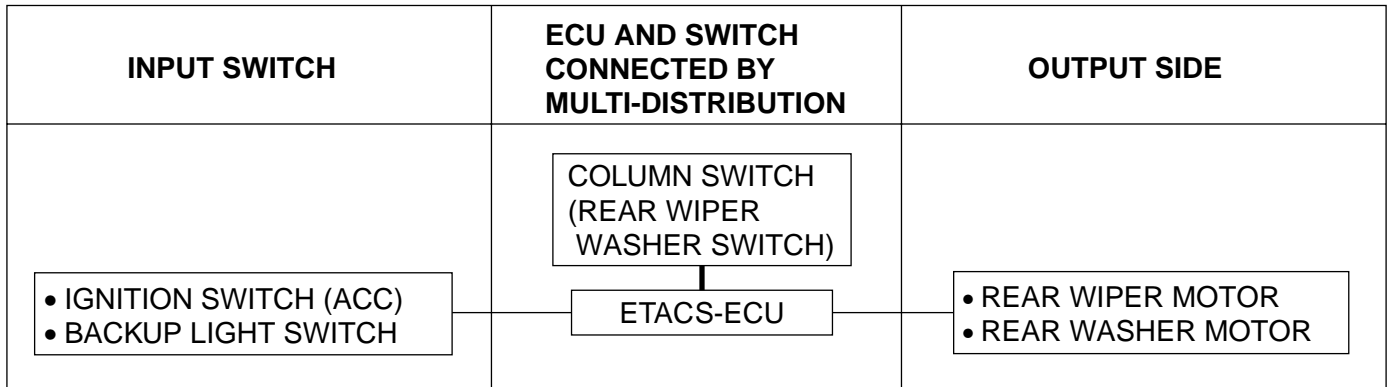

AC210163AB

LIGHTING

- Headlight and tail light
- Headlight automatic shutdown function

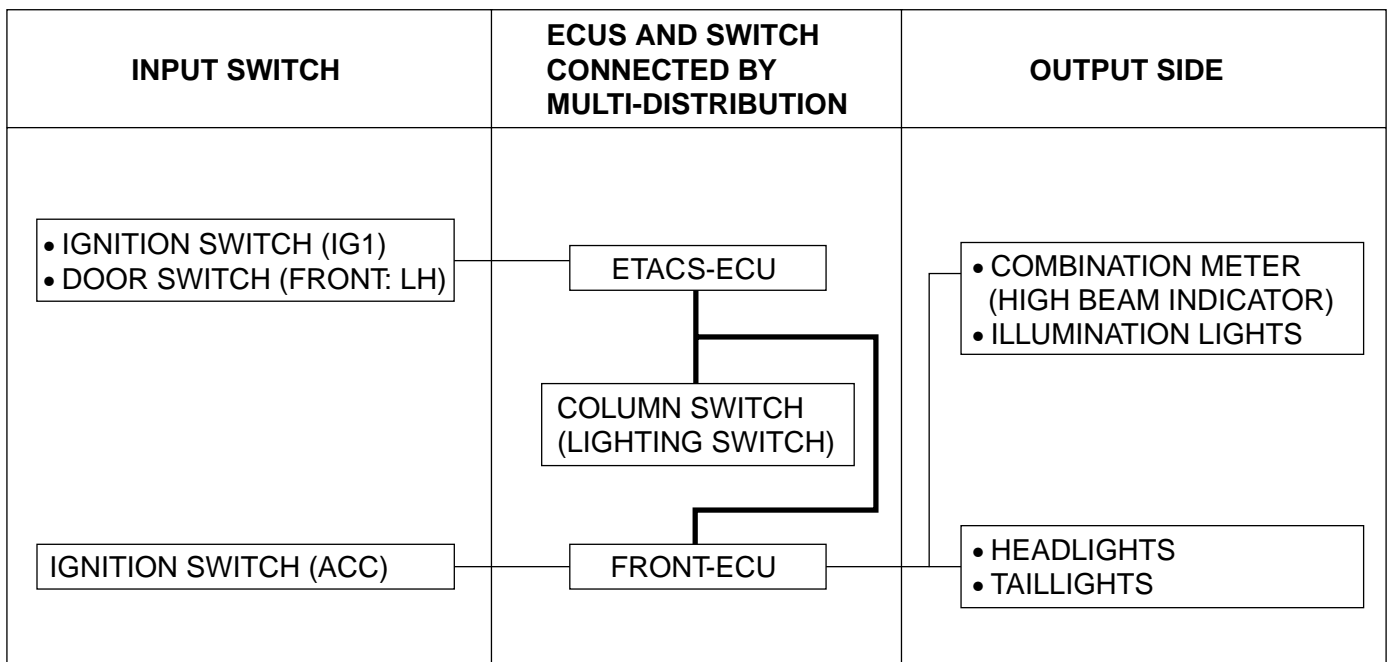

AC210164AB

FLASHER

- Turn signal light
- Headlight warning light

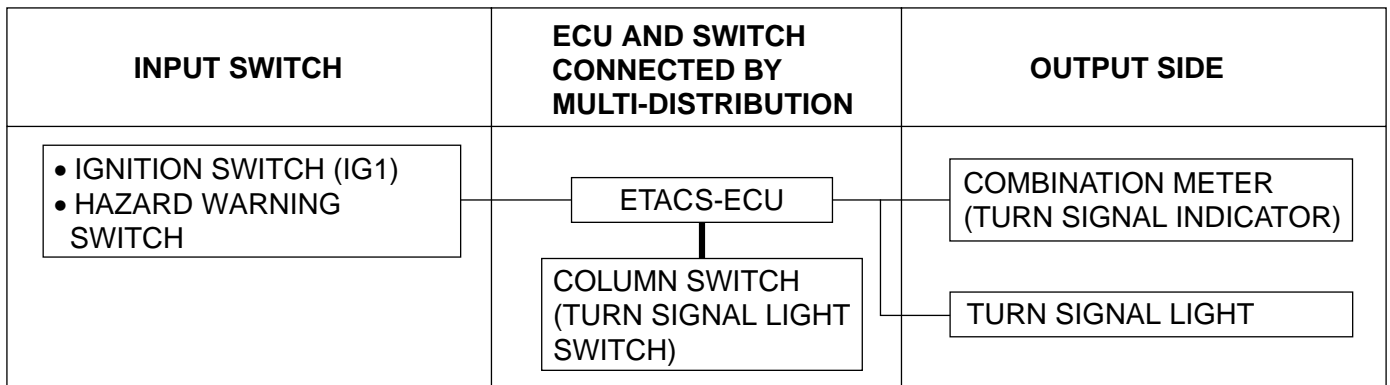

AC210165AB

DIAGNOSTIC FUNCTION

M2541003000136

DIAGNOSTIC TROUBLE CODE SET

The ETACS-ECU sends diagnostic trouble codes if the communication line is faulty when the scan tool is connected.

NOTE: Refer to the Service Manual for details of the diagnostic items.

SWS INPUT SIGNAL CHECK BY SCAN TOOL

When the scan tool is connected to the data link connector, and switches input for the SWS are operated, the tone alarm in the scan tool sounds, indicating whether the operations of the switches are satisfactory or not.

INPUT SIGNALS THAT CAN BE CHECKED

INPUT SIGNAL		CONDITIONS FOR SOUNDING TONE ALARM
Ignition switch (ACC)		Turn from "LOCK" (OFF) to "ACC" position
Ignition switch (IG1)		Turn from "ACC" to "ON" position
Key reminder switch		Remove the ignition key from ignition key cylinder (from inserted position)
Hazard light switch		Turn from OFF to ON
Driver's seat belt switch		Remove the seat belt tongue from the seat belt buckle with the ignition key in the "ON" position
Driver's, passenger's or rear door switch		Open the door
Driver's or passenger's door lock key cylinder switch		Turn the key to the lock or unlock position
Driver's door lock actuator switch		Move the door lock knob from lock position to unlock position or vice versa
Door lock switch (incorporated in power window main switch and power window sub switch)		Press "LOCK" or "UNLOCK" side
Backup light switch		Move the shift lever to the "R" position
Vehicle speed sensor		Speed changes from less than 10 km/h to more than 10 km/h
Column switch	Tail light switch	Lighting switch is turned to the tail light position
	Headlight switch	
	Dimmer switch	
	Passing switch	
	Turn signal light LH switch	
	Turn signal light RH switch	
	Windshield mist wiper switch	
	Windshield intermittent wiper switch	
	Windshield low speed wiper switch	
	Windshield high speed wiper switch	
	Windshield intermittent wiper interval adjusting knob	Turned from FAST to SLOW (Output once near the centre)
Windshield washer switch	Switch is turned from the OFF to the ON position	
Interior light loaded signal		Interior lights illuminated

FUNCTIONS AND CONTROL OF SWS ECUS

M2541004000151

The following functions are controlled by the SWS ECUs:

FUNCTION		CONTROL ECU	DESCRIPTION
TONE ALARM	Ignition key reminder tone alarm function	ETACS-ECU	P.54B-7
	Light reminder tone alarm function	ETACS-ECU, column switch	P.54B-7
	Seat belt tone alarm function	ETACS-ECU	P.54B-7
CENTRAL DOOR LOCKING SYSTEM	Door locking by operating the driver's or front passenger's door lock key cylinder		P.54B-8
	Door unlocking by operating the driver's door lock key cylinder		P.54B-8
	Door unlocking by operating the front passenger's door lock key cylinder		P.54B-8
	Door locking or unlocking by operating the driver's or front passenger's door lock switch		P.54B-8
KEYLESS ENTRY	Keyless entry hazard answerback and horn answerback function		P.54B-9
	Timed locking mechanism		P.54B-9
POWER WINDOW	Power window timer function	ETACS-ECU, power window main switch	P.54B-10
Sunroof	Sunroof timer function	ETACS-ECU, sunroof-ECU	P.54B-10
WINDSHIELD WIPER AND WASHER	Windshield wiper intermittent control (vehicle speed-dependent variable type)	ETACS-ECU, front-ECU, column switch	P.54B-10
	Mist wiper control		P.54B-11
	Low speed wiper and high speed wiper control		P.54B-11
	Washer control		P.54B-12
REAR WIPER AND WASHER	Rear wiper control	ETACS-ECU, column switch	P.54B-13
	Rear washer control		P.54B-13
HEADLIGHT	Headlight automatic-shutdown function	ETACS-ECU, front-ECU, column switch	P.54B-14
FOG LIGHT	Fog light control		P.54B-14
FLASHER TIMER FUNCTION	Turn signal light	ETACS-ECU, column switch	P.54B-15
	Hazard light		P.54B-15
INTERIOR LIGHT	Dome light control function	ETACS-ECU	P.54B-15
	Interior light automatic-shutdown function		P.54B-16
	Seat belt warning light function		P.54B-16
	Door-ajar indicator light function		P.54B-16
CONFIGURATION FUNCTION		ETACS-ECU, column switch	P.54B-17

TONE ALARM

Ignition key reminder tone alarm function

When the driver's door is opened with the ignition key inserted in the ignition key cylinder (ignition switch is in the OFF position,) the tone alarm sounds intermittently to indicate that the ignition key has not been removed.

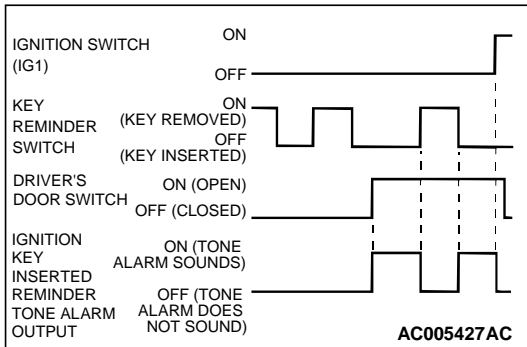

Light reminder tone alarm function

When the taillights or headlights are ON, if the ignition key is removed and the driver's door is opened, a tone alarm will sound continuously to warn that the lights are on. However, if the taillights or headlights have been turned off by the headlight automatic-shutdown function, the tone alarm will not sound.

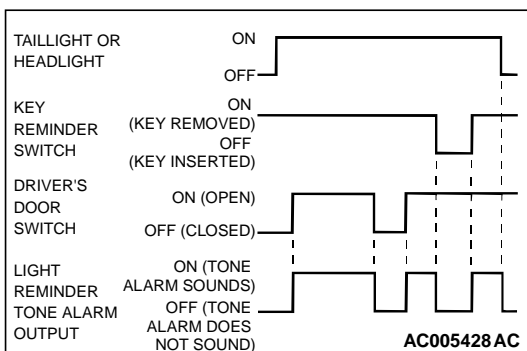

Seat belt tone alarm function

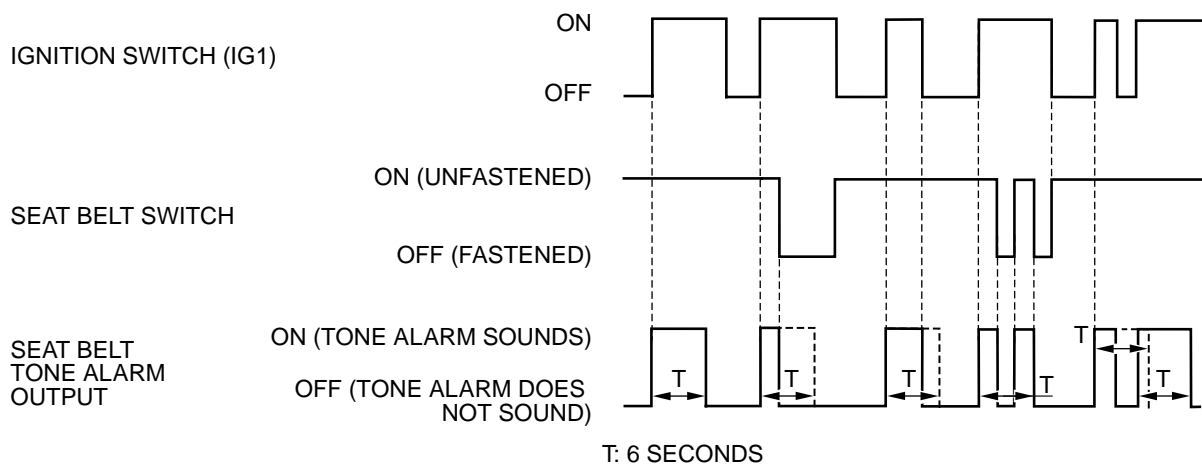

When the ignition switch is turned to ON position without fastening the driver's seat belt (driver's seat belt switch off), the tone alarm will sound for approximately six seconds to warn the driver to fasten the seat belt. When the driver's seat belt is fastened or the ignition switch is turned to OFF position, the tone alarm will stop sounding.

CENTRAL DOOR LOCKING SYSTEM

Door locking by operating the driver's or front passenger's door lock key cylinder

When the key is inserted in the driver's or front passenger's door lock key cylinder and turned counterclockwise to lock the door, the ETACS-ECU operates its door lock relay and passes a current through the door lock actuators of all doors and the liftgate for 0.25 seconds to lock all doors and the liftgate.

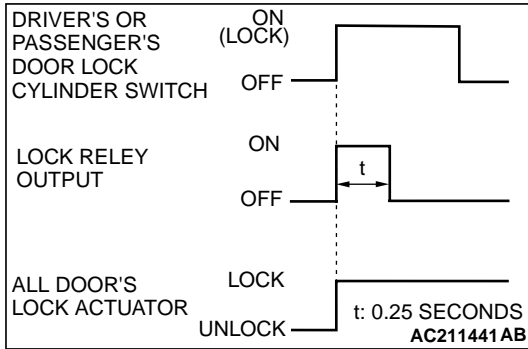

Door unlocking by operating the driver's door lock key cylinder

When the ignition key is inserted in the driver's door lock key cylinder and turned clockwise to unlock the driver's door, the ETACS-ECU operates its door unlock relay and passes a current through the door lock actuator of the driver's door for 0.25 seconds to unlock only the driver's door.

When the ignition key is turned clockwise, the ETACS-ECU operates its door unlock relay and passes a current through the door lock actuators of all doors for 0.25 seconds and to unlock all doors.

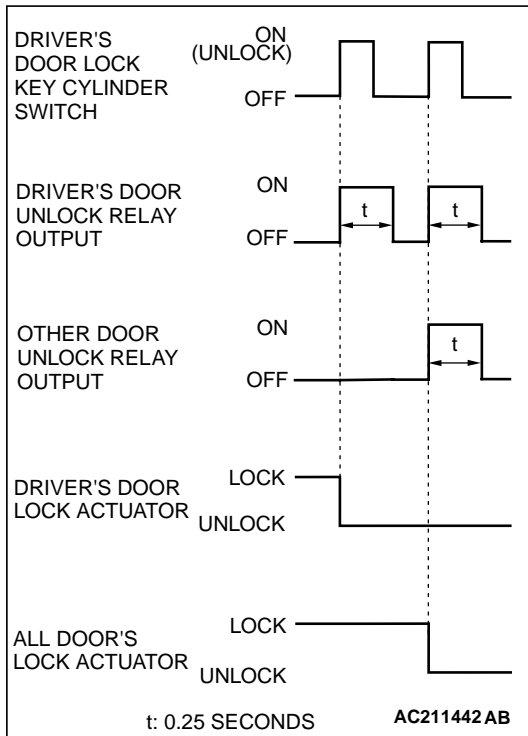

Door unlocking by operating the front passenger's door lock key cylinder

When the ignition key is inserted in the front passenger's door lock key cylinder and turned clockwise to unlock the front passenger's door, the ETACS-ECU operates its door unlock relay and passes a current through the door lock actuators of all doors for 0.25 seconds to unlock all doors.

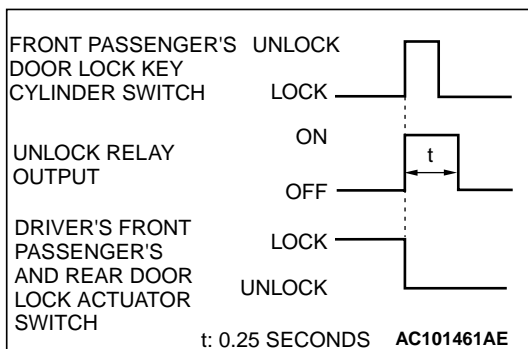

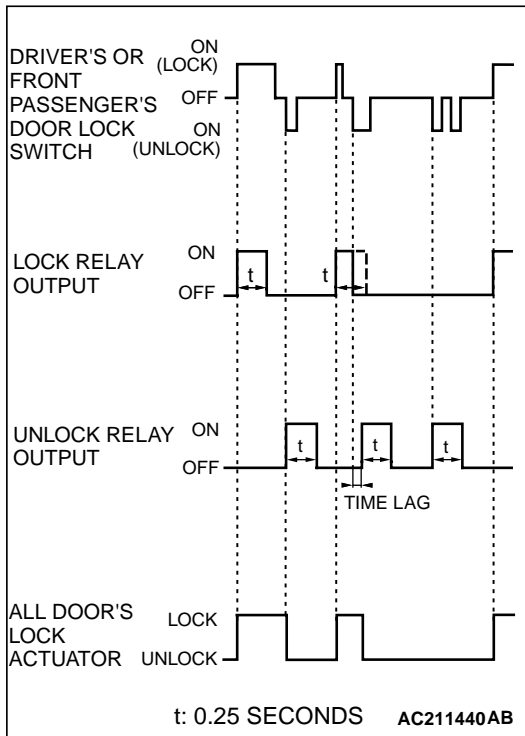

Door locking or unlocking by operating the driver's or front passenger's door lock switch

When the door is locked by the driver's or front passenger's door lock switch, the ETACS-ECU operates its door lock relay and passes a current through the door lock actuators of all doors for 0.25 seconds to lock all doors.

When the door is unlocked by the driver's or front passenger's door lock switch, the ETACS-ECU operates its door unlock relay and passes a current through the door lock actuators of all doors for 0.25 seconds to unlock all doors.

When the door is locked and unlocked by driver's or front passenger's door lock switch consecutively, the ETACS-ECU operates its door lock relay and passes a current through the door lock actuators of all doors for 0.25 seconds to lock all doors. Then, the ETACS-ECU operates its door unlock relay and passes a current through the door lock actuators of all doors for 0.25 seconds to unlock all doors. Due to this, there may be a time lag between the driver's or front passenger's door lock switch actuation and the time when all doors is unlocked.

KEYLESS ENTRY

Keyless entry hazard answerback and horn answerback function

When the lock signal is input from the keyless entry transmitter to the ETACS-ECU, the hazard warning light flashes twice and the horn sounds once. When the unlock signal is input, hazard warning light flashes once.

NOTE: Hazard answerback function can be disabled. (Refer to P.54B-17.)

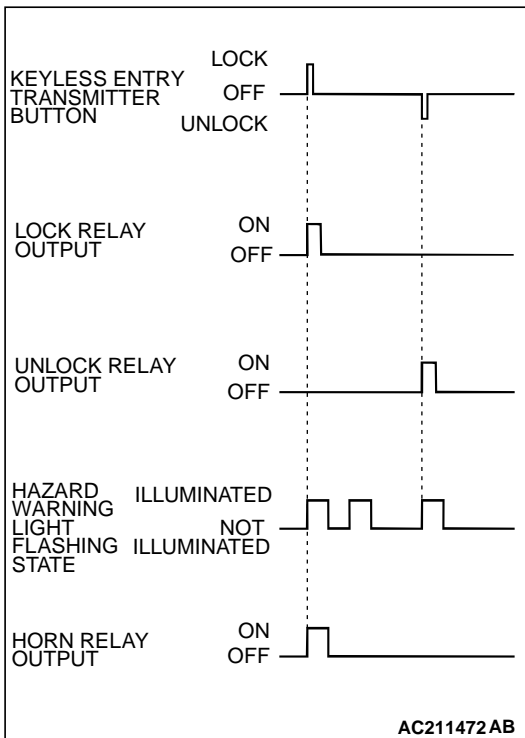

Timed locking mechanism

After unlocking the doors with the keyless entry transmitter, if no doors are opened, if the key is not inserted or if the locking function is not operated, the ETACS-ECU automatically locks the doors in 30 seconds.

POWER WINDOW

Power window timer function

When the ignition switch is turned to the "ON" position, the power window relay is turned ON. After the ignition switch is turned OFF, the system continues to turn ON the power window relay for about 30 seconds to enable opening and closing of the door window. When the driver's or front passenger's door is opened while the timer is in operation, the power window relay will be turned OFF.

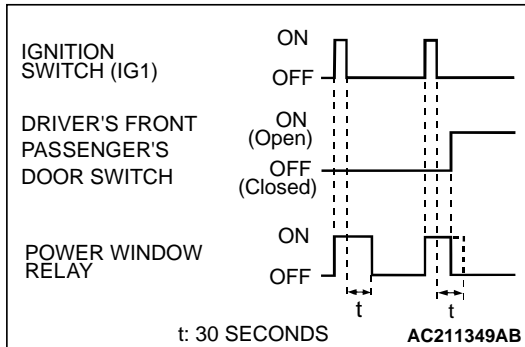

SUNROOF

Sunroof timer function

The ETACS-ECU enables opening and closing of the sunroof for 30 seconds after the ignition is switched off. During this timed operation, if the driver's door or passenger's door is opened, the sunroof timer function is deactivated from that moment.

WINDSHIELD WIPER AND WASHER

Intermittent control (vehicle speed-dependent variable type)

The ETACS-ECU calculates the intermittent time according to the vehicle speed calculated from the windshield wiper intermittent time adjusting knob and vehicle speed signal (ECM) and sends it to the front-ECU as SWS data.

NOTE: This function can be disabled by the configuration function. (Refer to P.54B-17.)

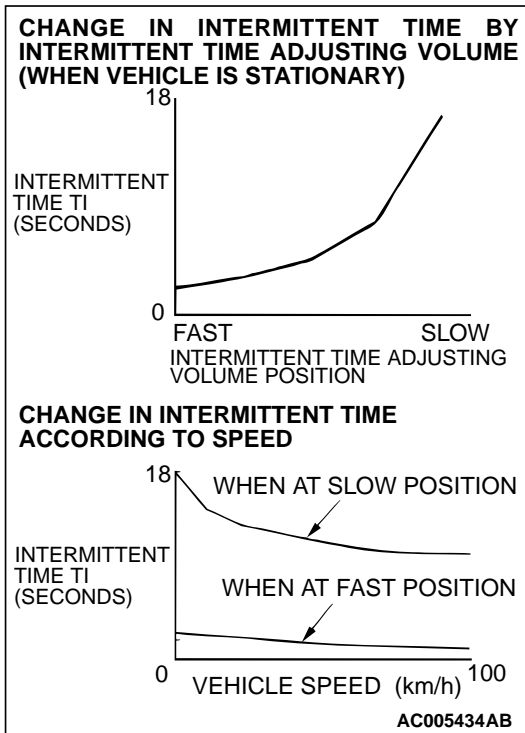

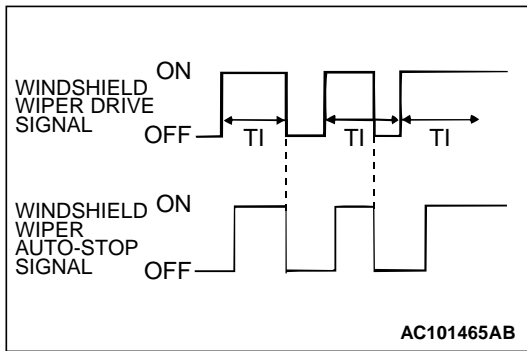

The front-ECU determines the intermittent time T_I from the input SWS data signal, and turns ON the windshield wiper drive signal. When the wiper is at the STOP position, the windshield wiper auto-stop signal goes OFF to turn OFF the windshield wiper drive signal. After the intermittent time T_I seconds from when the windshield wiper drive signal turned ON, the windshield wiper drive signal is turned ON again and the above operation is repeated.

Mist wiper control

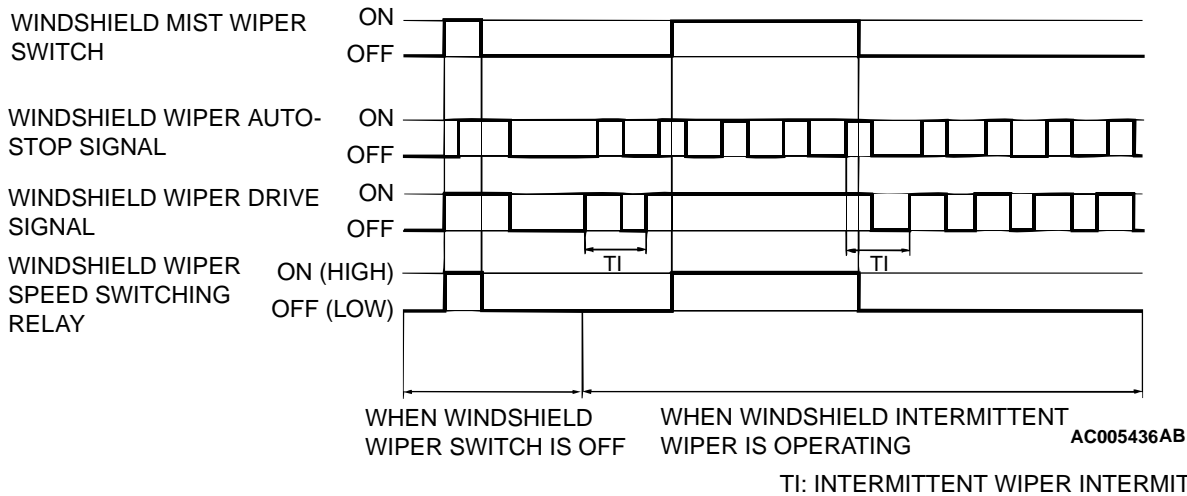

When the ignition switch is at the ACC or ON position, if the windshield mist wiper switch of the column switch is turned ON, the front-ECU turns ON the windshield wiper drive signal. At the same time, the wiper speed switching relay is turned ON (HIGH-SPEED). While the windshield mist wiper switch is ON, the windshield wiper will operate at high speed. Then, if the windshield mist wiper switch is turned off, the wiper operates at low speed until it stops at the predetermined park position.

When the windshield mist switch is turned on briefly, the wiper operates at low speed once. At the point the windshield mist switch is turned ON, if the windshield wiper has been operating intermittently, the same operations as the above will be performed while the windshield mist wiper switch is ON. After the windshield mist wiper switch goes OFF, the intermittent operations will be set again T_I seconds after the windshield wiper auto-stop signal is turned ON last.

Low speed wiper and high speed wiper control

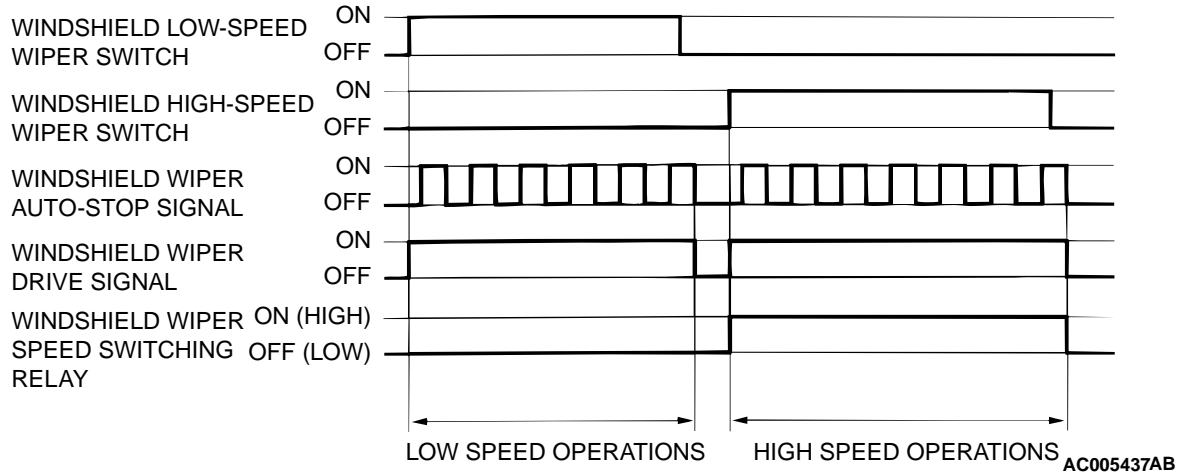

When the ignition switch is at the ACC or ON position, if the windshield low speed wiper switch of the column switch is turned ON, the front-ECU turns ON the windshield wiper drive signal, turns OFF (LO) the windshield wiper speed relay, and operates the wind-

shield wiper at low speed. Next, when the windshield high speed wiper switch is turned ON, the windshield wiper drive signal is turned ON, the windshield wiper speed switching relay is turned ON (HI), and the windshield wiper is operated at high speed.

Washer control

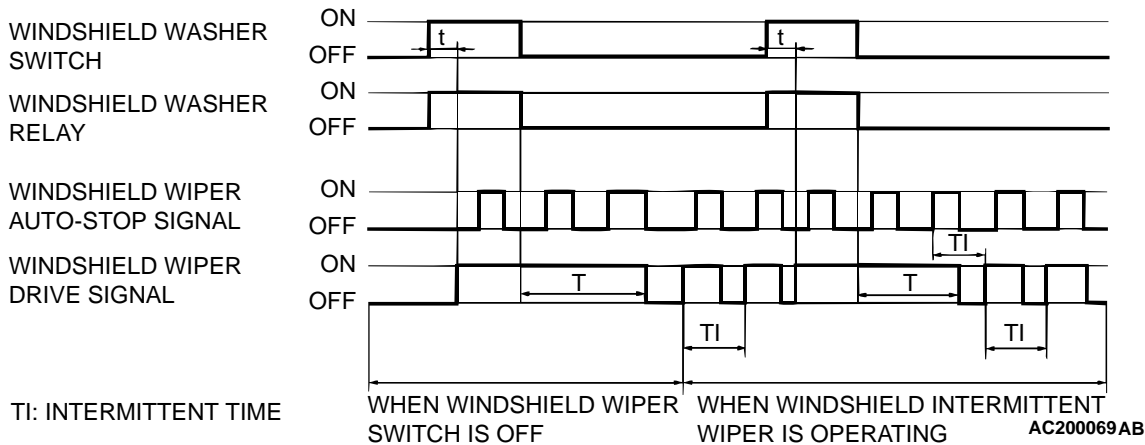

When the ignition switch is at the ACC or ON position, if the windshield washer switch of the column switch is turned ON, the front-ECU turns ON the windshield washer relay. The windshield wiper drive signal is turned ON in 0.3 seconds until three seconds after the windshield washer switch goes OFF to

operate the windshield wiper continuously. When the windshield washer switch is turned ON, if the windshield wiper is operating intermittently, intermittent operations will be continued after continuous operation.

NOTE: The wiper drive signal output time varies according to the conditions. Refer to the following table for details.

	WHEN WIPER SWITCH IS OFF				WHEN WIPER SWITCH IS INT				WHEN WIPER SWITCH IS SET TO LO OR HI
t	0.3 seconds or less	0.3 - 0.5 seconds	0.5 - 0.7 seconds	0.7 seconds	Less than 0.2 seconds	0.3 - 0.5 seconds	0.5 - 0.7 seconds	0.7 seconds	-
T	0 second	1 second	2 seconds	3 seconds	0 second	1 second	2 seconds	3 seconds	3 seconds

REAR WIPER AND WASHER

Rear wiper control

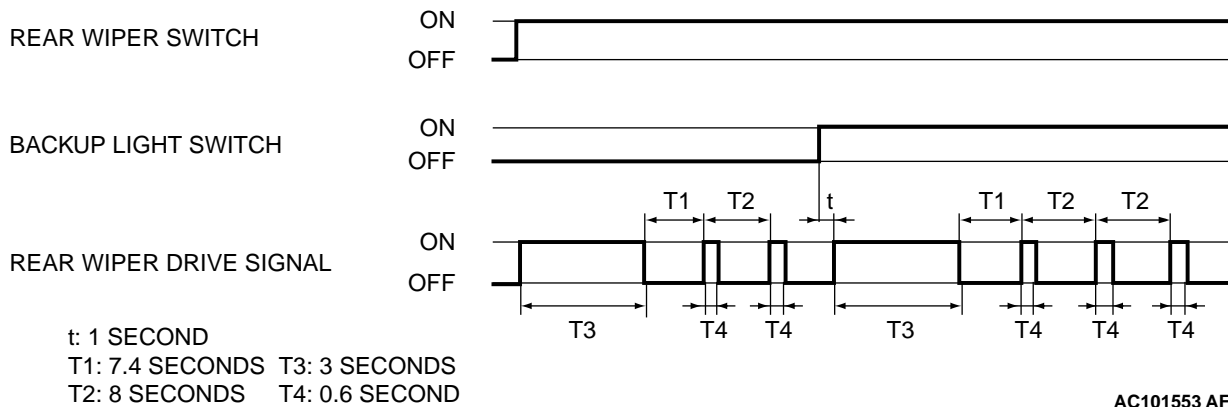

If the rear wiper switch of the column switch assembly is turned ON with the ignition switch in the ACC or ON position, the ETACS-ECU will turn the rear wiper drive signal ON for three seconds (approximately two operations), and then will carry out intermittent operation in a 7.4 to 8-second cycle.

If the shift lever is moved to the "R" position when the rear wiper switch of the column switch assembly is turned ON and the ignition switch is in any position other than OFF, the back up light switch "R" position switch turns ON. One second later, the ETACS-ECU turns the rear wiper drive signal ON for three seconds (approximately two operations), to clear the rear view, and then returns to intermittent operation at a 7.4 to 8-second cycle.

REAR WASHER CONTROL

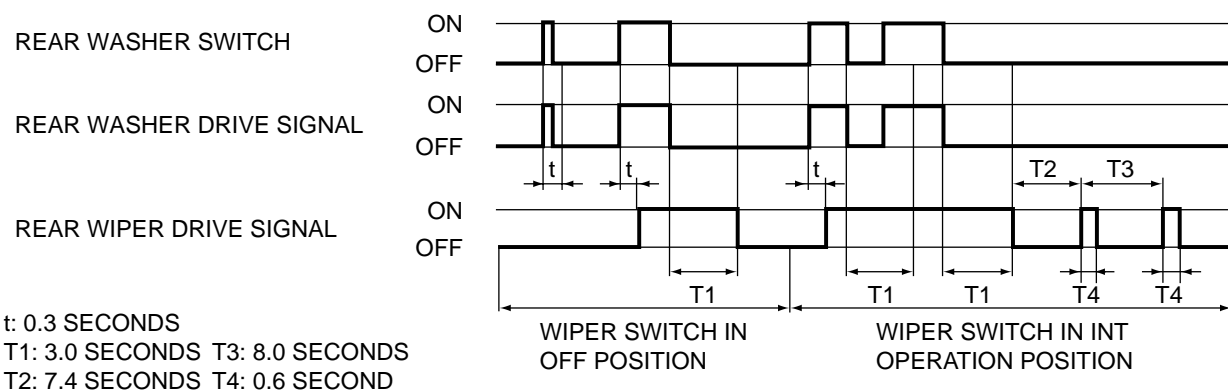

When the ignition switch is at the ACC or ON position, if the rear washer switch of the column switch is turned ON, the ETACS-ECU turns ON the rear washer relay. The rear wiper drive signal is turned ON in 0.3 seconds until three seconds after the rear washer switch goes OFF to operate the rear wiper continuously.

If the rear wiper is in intermittent operation when the rear washer switch is turned ON, 7.4 seconds after the rear wiper drive signal turns OFF, the 8-second cycle intermittent operation will continue.

HEADLIGHT

Headlight automatic-shutdown function

If the lighting switch (taillight switch or headlight switch) is ON, the headlights (including the taillights) will automatically go off in the following conditions to prevent the battery from discharging.

When the ignition key is turned from "ON" to "LOCK" (OFF) or "ACC" position with the lighting switch turned ON, and this state continues for three minutes, the light will automatically be turned off. If the driver's door is opened during these three minutes, the light will go off one second later.

NOTE: This function can be disabled. (Refer to P.54B-17.)

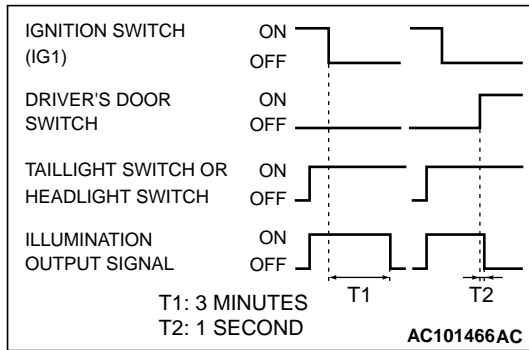

FOG LIGHT

Fog light control

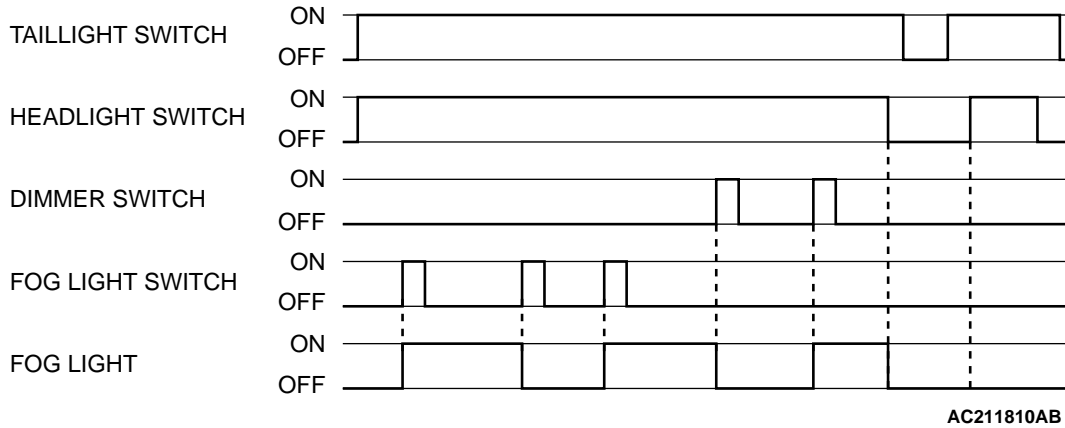

The fog lights will illuminate only when the fog light switch is operated while the low-beam headlights are on.

The fog lights will be switched off when any of the following conditions is met. The fog lights will also be switched off automatically by headlight automatic shutdown function.

- When the high-beam headlights are switched on, the fog lights will be switched off. If the low-beam headlights are switched on again, the fog lights will illuminate again.
- When the headlight switch is turned off while the taillights are on or the taillights and headlights are off, the fog lights will be switched off. If the low-beam headlights are switched on again, the fog lights will not illuminate again.

FLASHER TIMER FUNCTION

Turn signal light

The turn signal light output (flashing signal) is turned ON when the turn signal light ignition switch is ON and the turn signal light switch is ON (LH or RH.) If the front turn signal light or rear turn signal light bulb has burned out, the indicator light flashing speed increases to indicate that the turn signal bulb has burned out.

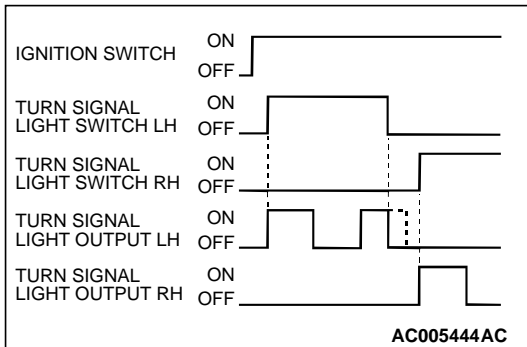

Hazard light

Detects the signal if the hazard light switch input changes from OFF to ON. The hazard lights toggle on and off whenever the hazard light switch is operated.

NOTE: The hazard light switch is a push-return type toggle switch.

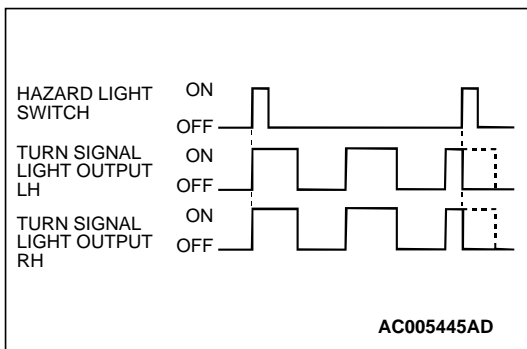

DOME LIGHT

Dome light control function

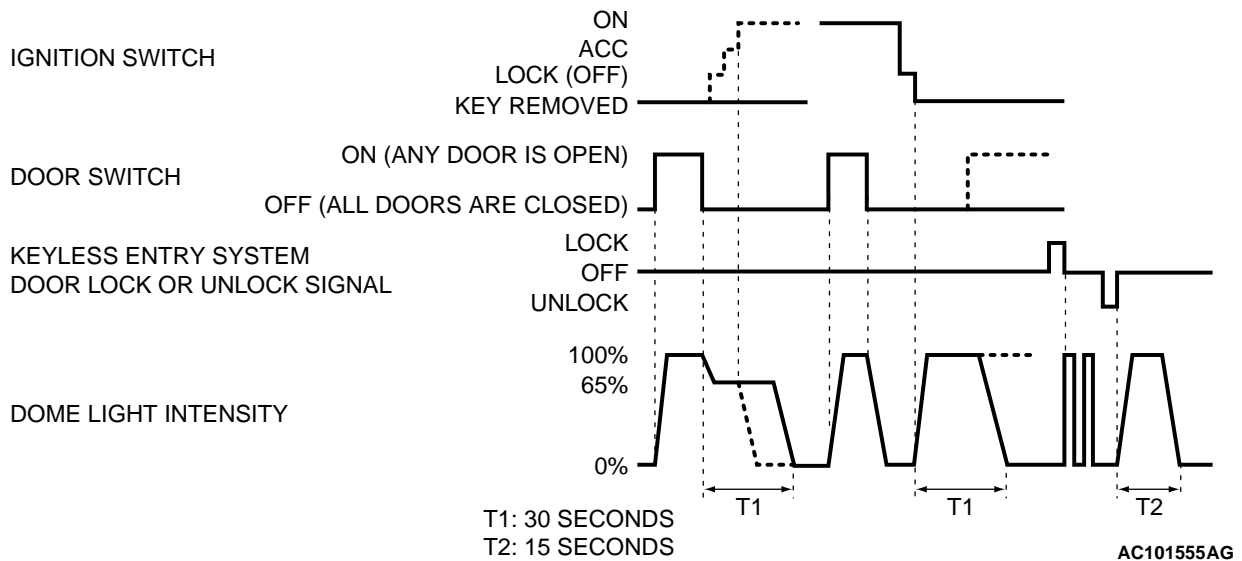

NOTE: The dotted lines in the graph indicate that lighting mode when the ignition switch is turned ON, door is locked, or any door is opened during the timer illumination time.

When the dome light switch is at the DOOR position, the ETACS-ECU controls the lighting of the dome light as follows:

- When a door is opened with the ignition switch off, the dome light lights up at a luminance of 100 percent. When a door is closed, the dome light dims at a luminance of 65 percent, and goes off 30 seconds later. However if the ignition switch is turned ON or if a door is locked while the dome light is dimming, the dome light will go off at that point.
- When a door is opened with the ignition switch ON, the dome light lights up at a luminance of 100 percent. When a door is closed, the dome light goes off.

- When the ignition key is removed with all doors closed, the dome light lights up at a luminance of 100 percent, and goes off 30 seconds later. However if the ignition key is inserted again or if a door is locked while the dome light is lighting, the dome light will go off at that point.
- To check keyless entry operations more easily, the dome light is flashed twice when the door is locked. When the door is unlocked, the dome light lights at a luminance of 100 percent, and goes off 15 seconds later.

NOTE: This function can be disabled. (Refer to P.54B-17.)

Interior light automatic-shutdown function

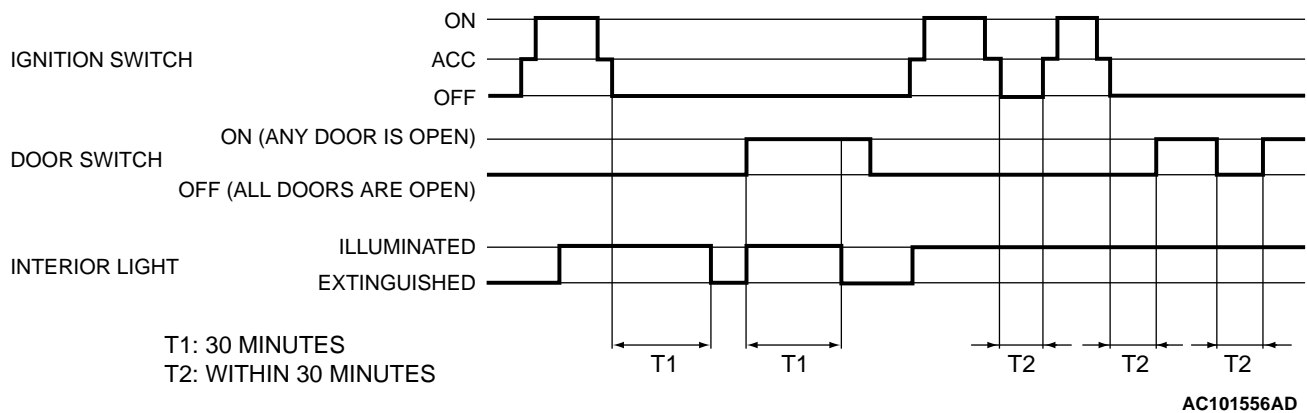

Illuminated interior lights such as the front dome light, etc. (all lights using the dome light fuse as the power supply) will automatically go off in the following conditions to prevent the battery from discharging as a result of forgetting to turn off the lights or incomplete closing of the door.

- When the ignition switch is turned off and more than 30 minutes pass by with the interior light illuminated, the interior lights will go off automatically.

- When the ignition switch is turned off and one of the door switches remains open for 30 minutes continuously, the interior lights will go off automatically.

NOTE: This function can be disabled. (Refer to P.54B-17.)

Seat belt warning light function

If the driver turns the ignition switch to ON position without fastening the driver's seat belt, the seat belt warning light illuminate to alert the driver to put on the seat belt.

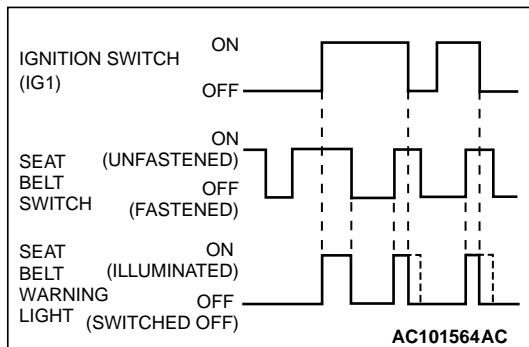

Door-ajar indicator light function

This indicator light warns the driver that door(s) are not closed. If a door switch is on, the ETACS-ECU operates the door-ajar indicator light on the combination meter.

CONFIGURATION FUNCTION

According to the configuration mode entry conditions of the input switch, the following functions can be disabled. The data on configuration will be memorized even if the battery is removed.

- Keyless entry system hazard answerback function
- Power window timer function
- Vehicle speed-dependent wiper function
- Headlight automatic-shutdown function
- Delayed light-off time of the dome light
- Interior light automatic-shutdown function
- Initialization of all functions (Returns to initial settings)

1. Conditions for entering the configuration mode

1. Set each switches to the following state:
 - Hazard light switch: OFF
 - Diagnosis control: ON (Connect the MUT-II/III or ground number 1 terminal of the diagnosis connector.)
 - Key reminder switch: OFF (Insert the ignition key)
 - Ignition switch: "LOCK" (OFF) position

- Driver's door switch: OFF (driver's door closed)
2. When the windshield washer switch is ON for more than ten seconds, the tone alarm in the ETACS-ECU sounds for three seconds, and the configuration mode will be set.
 2. Conditions for exiting the configuration mode
 - Diagnosis control: OFF (Disconnect the MUT-II/III or ground of Pin 1 of the diagnosis connector.)
 - Key reminder switch: ON (Remove the ignition key)
 - Ignition switch: Turn to any position other than "LOCK" (OFF) position
 - Driver's door switch: ON (driver's door opened)
 - Three minutes pass without configurations performed
 - Another warning tone alarm output is generated
 3. Configurations of various functions

FUNCTION	CONFIGURATION PROCEDURE
Keyless entry system hazard answerback function	When the lock switch of the transmitter is pressed twice continuously within two seconds, the hazard answerback function during the lock state will be switched between available and unavailable. <ul style="list-style-type: none"> • Function available: Tone alarm sounds once. (Initial state) • Function not available: Tone alarm sounds twice. When the unlock switch of the transmitter is pressed twice continuously within two seconds, the hazard answerback function during the unlock state will be switched between available and unavailable. <ul style="list-style-type: none"> • Function available: Tone alarm sounds once. (Initial state) • Function not available: Tone alarm sounds twice.
Power window timer function	When one of the power window main switch turns ON twice within two seconds (however there must be an interval of more than 0.3 seconds,) the power window timer function will be switched between available and unavailable. <ul style="list-style-type: none"> • Function available: Tone alarm sounds twice. (Initial state) • Function not available: Tone alarm sounds five times.
Vehicle speed-dependent wiper function	When the windshield wiper mist switch is turned ON for more than two seconds, the vehicle speed-dependent wiper function is switched between available and unavailable. <ul style="list-style-type: none"> • Function available: Tone alarm sounds once. (Initial state) • Function not available: Tone alarm sounds twice.

FUNCTION	CONFIGURATION PROCEDURE
Headlight automatic-shutdown function	<p>When the passing switch is turned ON for more than two seconds with the auto-light switch ON and the turn signal light switch turned to RH, the headlight automatic-shutdown function is switched between available and unavailable.</p> <ul style="list-style-type: none"> • Function not available: Tone alarm sounds twice. • Function available: (when the taillight illuminates with the ignition switch turned to the "LOCK" (OFF) position, it is not automatically turned off): Tone alarm sounds three times. (Initial state)
Delayed light-off time of the dome light	<p>When the turn signal light switch is set in the order of RH to LH to RH to LH within three seconds from the LH position, the delayed light-off time is changed as follows:</p> <ol style="list-style-type: none"> a. 30 seconds: Tone alarm sounds once. (Initial state) b. 10 seconds: Tone alarm sounds twice. c. 0 seconds (No delay time): Tone alarm sounds three times. d. 15 seconds: Tone alarm sounds four times. e. 7.5 seconds: Tone alarm sounds five times. f. Returns to a after e, and repeats from a in order.
Interior light automatic-shutdown function	<p>When the hazard light switch is turned ON for more than two seconds, the interior light cut-off function is changed as follows: (a and b switches alternately)</p> <ol style="list-style-type: none"> a. Function available: Tone alarm sounds once. (Initial state) b. Function not available: Tone alarm sounds twice.
Initialization of all functions (Return to initial settings)	<p>When the windshield washer switch is ON for more than 20 seconds continuously, the tone alarm sounds twice, and all functions will be initialized. (Settings are returned to their initial states.) The configuration mode entry tone alarm sounds after 10 seconds. However, to initialize all functions, the windshield washer switch must stay ON for 20 seconds. When the windshield washer switch is ON for more than 20 seconds continuously without the configuration mode set, the configuration mode will be set after 10 seconds without the initialization of all functions.</p>