

HI7000/4 Series

(HI7000/4 V.2.02, HI7700/4 V.2.02, and HI7750/4 V.2.02)

User's Manual

Renesas Microcomputer Development Environment System

User's Manual

Keep safety first in your circuit designs!

1. Renesas Technology Corp. puts the maximum effort into making semiconductor products better and more reliable, but there is always the possibility that trouble may occur with them. Trouble with semiconductors may lead to personal injury, fire or property damage.
Remember to give due consideration to safety when making your circuit designs, with appropriate measures such as (i) placement of substitutive, auxiliary circuits, (ii) use of nonflammable material or (iii) prevention against any malfunction or mishap.

Notes regarding these materials

1. These materials are intended as a reference to assist our customers in the selection of the Renesas Technology Corp. product best suited to the customer's application; they do not convey any license under any intellectual property rights, or any other rights, belonging to Renesas Technology Corp. or a third party.
2. Renesas Technology Corp. assumes no responsibility for any damage, or infringement of any third-party's rights, originating in the use of any product data, diagrams, charts, programs, algorithms, or circuit application examples contained in these materials.
3. All information contained in these materials, including product data, diagrams, charts, programs and algorithms represents information on products at the time of publication of these materials, and are subject to change by Renesas Technology Corp. without notice due to product improvements or other reasons. It is therefore recommended that customers contact Renesas Technology Corp. or an authorized Renesas Technology Corp. product distributor for the latest product information before purchasing a product listed herein.
The information described here may contain technical inaccuracies or typographical errors. Renesas Technology Corp. assumes no responsibility for any damage, liability, or other loss rising from these inaccuracies or errors.
Please also pay attention to information published by Renesas Technology Corp. by various means, including the Renesas Technology Corp. Semiconductor home page (<http://www.renesas.com>).
4. When using any or all of the information contained in these materials, including product data, diagrams, charts, programs, and algorithms, please be sure to evaluate all information as a total system before making a final decision on the applicability of the information and products. Renesas Technology Corp. assumes no responsibility for any damage, liability or other loss resulting from the information contained herein.
5. Renesas Technology Corp. semiconductors are not designed or manufactured for use in a device or system that is used under circumstances in which human life is potentially at stake. Please contact Renesas Technology Corp. or an authorized Renesas Technology Corp. product distributor when considering the use of a product contained herein for any specific purposes, such as apparatus or systems for transportation, vehicular, medical, aerospace, nuclear, or undersea repeater use.
6. The prior written approval of Renesas Technology Corp. is necessary to reprint or reproduce in whole or in part these materials.
7. If these products or technologies are subject to the Japanese export control restrictions, they must be exported under a license from the Japanese government and cannot be imported into a country other than the approved destination.
Any diversion or reexport contrary to the export control laws and regulations of Japan and/or the country of destination is prohibited.
8. Please contact Renesas Technology Corp. for further details on these materials or the products contained therein.

1. TRON is an acronym of "The Realtime Operating system Nucleus", ITRON is an acronym of the "Industrial TRON", and μ ITRON is an acronym of the "Micro Industrial TRON".
2. TRON, ITRON, and μ ITRON are the names of computer specifications and do not indicate a specific group of the commodity or the commodity.
3. The μ ITRON4.0 specification is open realtime-kernel specification defined by the TRON association. The specification of μ ITRON4.0 can be downloaded from the TRON association homepage (<http://www.assoc.tron.org>).
4. The copyright of the μ ITRON specification belongs to the TRON association.
5. Microsoft® Windows® 98, Microsoft® Windows® Millennium Edition (Windows® Me) operating system, Microsoft® Windows NT® operating system, Microsoft® Windows® 2000 operating system, and Microsoft® Windows® XP operating system are registered trademarks of Microsoft Corporation in the United States and/or other countries.
6. SuperH™ is a trademark of Renesas Technology Corp.
7. All other product names are trademarks or registered trademarks of the respective holders.

Preface

This manual describes how to configure systems using the HI7000/4, HI7700/4, and HI7750/4 (hereinafter collectively referred to as the HI7000/4 series) embedded realtime multitasking operating systems based on μ ITRON4.0 specifications.

Please read this manual and the related manuals listed below before using the HI7000/4 series to fully understand the operating system.

This user's manual contains the following five sections and appendixes:

Section 1	Introduction to HI7000/4 series: general description of HI7000/4 series systems
Section 2	Kernel: overview of HI7000/4 series kernel functions.
Section 3	System calls: overview of HI7000/4 series kernel system calls.
Section 4	Applications: creating applications in C using sample programs
Section 5	System configuration method: configuring the system using the configurator
Appendixes	List of service call function codes, error references, user and kernel work area calculations, timer drivers, optional functions of HI7700/4 (optimized timer driver and DSP standby control function), note on FPU, and modified functions in the new version of the product.

The other relevant manuals are listed below:

- Release Notes provided for the product
- Manuals provided for the SuperH™ RISC engine C/C++ compiler package
- The hardware manual and programming manual of the SuperH™ microcomputer in use

Renesas Technology Homepage:

Various support information is available on the Renesas Technology homepage:

<http://www.renesas.com/en/tools/>

Abbreviations of products

Product Name	Description
HI7000/4 series	Abbreviation of HI7000/4, HI7700/4, and HI7750/4
DX	Abbreviation of Debugging Extension
HEW	Abbreviation of High-performance Embedded Workshop, which is an integrated development tool.

Symbols used in this manual have the following meanings:

- H' and D': For hexadecimal integers, prefix H' is attached. For decimal integers, prefix D' is attached. If no prefix is attached, a decimal integer is assumed.
- nnnn***: Bold-faced-italic ***nnnn*** is the CPU name used for the sample file name.
Example: The timer driver file name is ***nnnn***_tmrdrv.c in this manual, but the actual timer driver file for SH7708 is 7708_tmrdrv.c.
- ???: ??? is used for the file name in the HI7700/4 and HI7750/4. For big endian and little endian, big and little are used instead of ???, respectively.
- CFG_MAXTSKID: A variable name beginning with CFG_ is specified for the configurator by the user to use the configurator. For details, refer to section 5.4.6, Configurator Settings, and the configurator on-line help.

Contents

Section 1	Introduction	1
1.1	Overview	1
1.2	Features	1
1.3	Operating Environment	3
1.4	Installation	3
1.5	Target Product of This Manual	4
Section 2	Kernel	5
2.1	Overview	5
2.2	Functions	5
2.3	Processing Units and Precedence	6
2.4	System State	7
2.4.1	Task Context State and Non-Task Context State	8
2.4.2	Dispatch-Disabled State/Dispatch-Enabled State	8
2.4.3	CPU-Locked State/CPU-Unlocked State	9
2.5	Objects	9
2.6	Tasks	9
2.6.1	Task State and Transition	11
2.6.2	Task Creation	13
2.6.3	Task Initiation	13
2.6.4	Task Scheduling	14
2.6.5	Task Termination and Deletion	15
2.6.6	Task Stack	15
2.6.7	Shared Stack Function	16
2.6.8	Task Execution Mode	18
2.6.9	Exclusive Control	18
2.6.10	Task Event Flags	19
2.7	Task Exception Processing	20
2.8	Semaphore	22
2.9	Event Flag	24
2.10	Data Queue	26
2.11	Mailbox	28
2.12	Mutex	30
2.13	Message Buffer	32
2.14	Fixed-Size Memory Pool	35
2.15	Variable-Size Memory Pool	37
2.15.1	Overview	37
2.15.2	Controlling Fragmentation of Free Space	40
2.15.3	Management of Variable-Size Memory Pool	42
2.16	Time Management	43
2.16.1	Cyclic Handler	44
2.16.2	Alarm Handler	46
2.16.3	Overrun Handler	47
2.16.4	Notes on Time Management	48
2.17	System State Management	49
2.17.1	System Down	49
2.17.2	Service Call Trace Function	50

2.18	Interrupt Management and System Configuration Management	52
2.18.1	Resetting the CPU and Initiating the Kernel.....	53
2.18.2	Interrupt Handlers.....	54
2.18.3	Disabling Interrupts.....	55
2.18.4	Kernel Interrupt Mask Level (CFG_KNLMSKLVL):	57
2.18.5	CPU Exception.....	58
2.19	Service Call Management	59
2.20	Cache Support (only for HI7700/4 and HI7750/4)	60
2.21	Kernel Idling	62
2.22	Pre-fetch Function (only for HI7700/4 and HI7750/4)	62
2.23	Optimized Timer Driver (only for HI7700/4)	62
2.24	DSP Standby Control Function (only for HI7700/4)	62
Section 3	Service Calls	63
3.1	Overview	63
3.2	Service Call Interface	64
3.2.1	C Language API	64
3.2.2	Assembly Language API	66
3.2.3	Guarantee of Register Contents after Issuing Service Call.....	67
3.2.4	Return Value of Service Call and Error Code.....	69
3.2.5	System State and Service Calls.....	69
3.2.6	Service Calls not in the μ TRON4.0 Specification.....	72
3.3	Service Call Description Form.....	73
3.4	Task Management	74
3.4.1	Create Task	76
3.4.2	Delete Task (del_tsk).....	80
3.4.3	Initiate Task (act_tsk, iact_tsk).....	81
3.4.4	Cancel Task Initiation Request (can_act, ican_act)	82
3.4.5	Start Task (Start Code Specified) (sta_tsk, ista_tsk).....	83
3.4.6	Exit Current Task, Exit and Delete Current Task (ext_tsk), (exd_tsk).....	84
3.4.7	Terminate Task (ter_tsk).....	86
3.4.8	Change Task Priority (chg_pri, ichg_pri)	87
3.4.9	Refer to Task Priority (get_pri, iget_pri)	88
3.4.10	Refer to Task State (ref_tsk, iref_tsk).....	89
3.4.11	Refer to Task State (Simple Version) (ref_tst, iref_tst).....	93
3.4.12	Change Task Execution Mode (vchg_tmd).....	95
3.5	Task Synchronization.....	96
3.5.1	Sleep Task (slp_tsk, tslp_tsk)	98
3.5.2	Wakeup Task (wup_tsk, iwup_tsk)	99
3.5.3	Cancel Wakeup Task (can_wup, ican_wup)	100
3.5.4	Release WAITING State Forcibly (rel_wai, irel_wai).....	101
3.5.5	Suspend Task (sus_tsk, isus_tsk).....	102
3.5.6	Resume Task Force, Task to Resume (rsm_tsk, irsm_tsk, frsm_tsk, ifrsm_tsk).....	103
3.5.7	Delay Task (dly_tsk).....	104
3.5.8	Set Task Event Flag (vset_tfl, ivset_tfl).....	105
3.5.9	Clear Task Event Flag (vclr_tfl, ivclr_tfl).....	106
3.5.10	Wait Task Event Flag (vwai_tfl, vpol_tfl, vtwai_tfl)	107
3.6	Task Exception Processing Functions.....	109
3.6.1	Define Task Exception Processing Routine (def_tex, ideof_tex).....	111
3.6.2	Request Task Exception Processing (ras_tex, iras_tex)	113
3.6.3	Disable Task Exception Processing (dis_tex)	114
3.6.4	Enable Task Exception Processing (ena_tex)	115
3.6.5	Refer To Task Exception Processing Disabled State (sns_tex).....	116

3.6.6	Refer to Task Exception Processing State (ref_tex, iref_tex)	117
3.7	Synchronization and Communication (Semaphore)	118
3.7.1	Create Semaphore	119
3.7.2	Delete Semaphore (del_sem).....	121
3.7.3	Returns Semaphore Resource (sig_sem, isig_sem)	122
3.7.4	Wait on Semaphore (wai_sem, pol_sem, ipol_sem, twai_sem).....	123
3.7.5	Refer to Semaphore State (ref_sem, iref_sem).....	125
3.8	Synchronization and Communication (Event Flag)	126
3.8.1	Create Event Flag	128
3.8.2	Delete Event Flag (del_flg).....	130
3.8.3	Set Event Flag (set_flg, iset_flg).....	131
3.8.4	Clear Event Flag (clr_flg, iclr_flg).....	132
3.8.5	Wait for Event Flag Setting (wai_flg, pol_flg, ipol_flg, twai_flg).....	133
3.8.6	Refer to Event Flag State (ref_flg, iref_flg)	135
3.9	Synchronization and Communication (Data Queue)	136
3.9.1	Create Data Queue	138
3.9.2	Delete Data Queue (del_dtq).....	140
3.9.3	Send Data to Data Queue (snd_dtq, psnd_dtq, ipsnd_dtq, tsnd_dtq, fsnd_dtq, ifsnd_dtq)	141
3.9.4	Receive Data from Data Queue (rcv_dtq, prcv_dtq, trcv_dtq)	143
3.9.5	Refer to Data Queue State (ref_dtq, iref_dtq)	145
3.10	Synchronization and Communication (Mailbox)	146
3.10.1	Create Mailbox.....	147
3.10.2	Delete Mailbox (del_mbx)	149
3.10.3	Send Message to Mailbox (snd_mbx, isnd_mbx).....	150
3.10.4	Receive Message from Mailbox (rcv_mbx, prcv_mbx, iprcv_mbx, trcv_mbx)	152
3.10.5	Refer to Mailbox State (ref_mbx, iref_mbx).....	154
3.11	Synchronization and Communication (Mutex)	156
3.11.1	Create Mutex (cre_mtx) (acre_mtx: Assign Mutex ID Automatically).....	157
3.11.2	Delete Mutex (del_mtx)	159
3.11.3	Lock Mutex (loc_mtx, ploc_mtx, tloc_mtx).....	160
3.11.4	Unlock Mutex (unl_mtx).....	162
3.11.5	Refer to Mutex State (ref_mtx)	163
3.12	Extended Synchronization and Communication (Message Buffer).....	164
3.12.1	Create Message Buffer	166
3.12.2	Delete Message Buffer (del_mbf)	169
3.12.3	Send Message to Message Buffer (snd_mbf, psnd_mbf, ipsnd_mbf, tsnd_mbf).....	170
3.12.4	Receive Message from Message Buffer (rcv_mbf, prcv_mbf, trcv_mbf).....	172
3.12.5	Refer to Message Buffer State (ref_mbf, iref_mbf).....	174
3.13	Memory Pool Management (Fixed-Size Memory Pool)	175
3.13.1	Create Fixed-Size Memory Pool	176
3.13.2	Delete Fixed-Size Memory Pool (del_mpf)	179
3.13.3	Get Fixed-Size Memory Block (get_mpf, pget_mpf, ipget_mpf, tget_mpf)	180
3.13.4	Release Fixed-Size Memory Block (rel_mpf, irel_mpf)	182
3.13.5	Refer to Fixed-Size Memory Pool State (ref_mpf, iref_mpf).....	183
3.14	Memory Pool Management (Variable-Size Memory Pool).....	184
3.14.1	Create Variable-Size Memory Pool	186
3.14.2	Delete Variable-Size Memory Pool (del_mpl)	190
3.14.3	Get Variable-Size Memory Block (get_mpl, pget_mpl, ipget_mpl, tget_mpl).....	191
3.14.4	Release Variable-Size Memory Block (rel_mpl, irel_mpl).....	193
3.14.5	Refer to Variable-Size Memory Pool State (ref_mpl, iref_mpl).....	194
3.15	Time Management (System Clock).....	195
3.15.1	Set System Clock (set_tim, iset_tim)	197
3.15.2	Get System Clock (get_tim, iget_tim).....	198

3.15.3	Supply Time Tick (isig_tim).....	199
3.16	Time Management (Cyclic Handler).....	200
3.16.1	Create Cyclic Handler	201
3.16.2	Delete Cyclic Handler (del_cyc)	203
3.16.3	Start Cyclic Handler (sta_cyc, ista_cyc).....	204
3.16.4	Stop Cyclic Handler (stp_cyc, istp_cyc).....	205
3.16.5	Refer to Cyclic Handler State (ref_cyc, iref_cyc).....	206
3.17	Time Management (Alarm Handler).....	207
3.17.1	Create Alarm Handler.....	208
3.17.2	Delete Alarm Handler (del_alm)	210
3.17.3	Start Alarm Handler (sta_alm, ista_alm)	211
3.17.4	Stop Alarm Handler (stp_alm, istp_alm).....	212
3.17.5	Refer to Alarm Handler State (ref_alm, iref_alm).....	213
3.18	Time Management (Overrun Handler).....	214
3.18.1	Define Overrun Handler (def_ovr)	215
3.18.2	Start Overrun Handler (sta_ovr, ista_ovr).....	216
3.18.3	Stop Overrun Handler Operation (stp_ovr, istp_ovr).....	217
3.18.4	Refer to Overrun Handler State (ref_ovr, iref_ovr)	218
3.19	System State Management	219
3.19.1	Rotate Ready Queue (rot_rdq, irot_rdq).....	220
3.19.2	Get Task ID in RUNNING State (get_tid, iget_tid).....	221
3.19.3	Lock CPU (loc_cpu, iloc_cpu)	222
3.19.4	Unlock CPU (unl_cpu, iunl_cpu)	224
3.19.5	Disable Dispatch (dis_dsp).....	225
3.19.6	Enable Dispatch (ena_dsp).....	226
3.19.7	Refer to Context (sns_ctx).....	227
3.19.8	Refer to CPU-Locked State (sns_loc).....	228
3.19.9	Refer to Dispatch-disabled State (sns_dsp)	229
3.19.10	Refer to Dispatch-Pended State (sns_dpn)	230
3.19.11	Start Kernel (vsta_knl, ivsta_knl).....	231
3.19.12	System Down (vsys_dwn, ivsys_dwn)	232
3.19.13	Acquire Trace Information (vget_trc, ivget_trc).....	233
3.19.14	Acquire Start of Interrupt Handler as Trace Information (ivbgn_int).....	234
3.19.15	Acquire End of Interrupt Handler as Trace Information (ivend_int)	235
3.20	Interrupt Management.....	236
3.20.1	Define Interrupt Handler (def_inh, ideof_inh).....	237
3.20.2	Change Interrupt Mask (chg_ims, ichg_ims).....	240
3.20.3	Refer to Interrupt Mask (get_ims, iget_ims).....	241
3.21	Service Call Management.....	242
3.21.1	Define Extended Service Call (def_svc, ideof_svc)	243
3.21.2	Call Service Call (cal_svc, ical_svc).....	244
3.22	System Configuration Management.....	245
3.22.1	Define CPU Exception Handler (def_exc, ideof_exc).....	246
3.22.2	Define CPU Exception (TRAPA Instruction Exception) Handler (vdef_trp, ideof_trp).....	248
3.22.3	Refer to Configuration Information (ref_cfg, iref_cfg)	250
3.22.4	Refer to Version Information (ref_ver, iref_ver).....	252
3.23	Cache Support Function (HI7700/4: for SH-3 and SH3-DSP)	254
3.23.1	Initialize Cache (vini_cac, ivini_cac)	256
3.23.2	Clear Cache (vclr_cac, ivclr_cac).....	258
3.23.3	Flush Cache (vfls_cac, ivfls_cac).....	259
3.23.4	Invalidate Cache (vinv_cac, ivinv_cac)	260
3.24	Cache Support Function (HI7750/4: for SH-4).....	261
3.24.1	Initialize Cache (vini_cac, ivini_cac)	263

3.24.2	Clear Operand Cache (vclr_cac, ivclr_cac)	264
3.24.3	Flush Operand Cache (vfls_cac, ivfls_cac)	265
3.24.4	Invalidate Operand Cache (vinv_cac, ivinv_cac)	266
3.25	Cache Support Function (HI7700/4: for SH4AL-DSP without Extended Function, HI7750/4: for SH-4A without Extended Function)	267
3.25.1	Initialize Cache (vini_cac, ivini_cac)	269
3.25.2	Clear Instruction/Operand Cache (vclr_cac, ivclr_cac)	271
3.25.3	Flush Operand Cache (vfls_cac, ivfls_cac)	273
3.25.4	Invalidate Instruction/Operand Cache (vinv_cac, ivinv_cac)	275
3.26	Cache Support Function (HI7700/4: for SH4AL-DSP with Extended Function, HI7750/4: for SH-4A with Extended Function)	277
3.26.1	Initialize Cache (vini_cac, ivini_cac)	279
3.26.2	Clear Instruction/Operand Cache (vclr_cac, ivclr_cac)	282
3.26.3	Flush Operand Cache (vfls_cac, ivfls_cac)	284
3.26.4	Invalidate Instruction/Operand Cache (vinv_cac, ivinv_cac)	286
Section 4 Application Program Creation		289
4.1	Header Files	289
4.1.1	Header Files for C/C++ Language	289
4.1.2	Header Files for Assembly Language	292
4.2	Handling the CPU Resources	293
4.2.1	SR Register	293
4.2.2	Cache Lock Function (SH-3, SH3-DSP)	294
4.2.3	VBR Register	295
4.2.4	MMU (SH-3, SH3-DSP, SH4AL-DSP, SH-4, SH-4A)	295
4.2.5	Acceptance of NMI while SR.BL = 1 (SH-3, SH3-DSP, SH4AL-DSP, SH-4, SH-4A)	295
4.2.6	Nesting the Interrupts (SH-3, SH3-DSP, SH4AL-DSP, SH-4, SH-4A)	295
4.2.7	32-Bit Address Extension Mode (SH-4A)	295
4.2.8	TBR Register (SH-2A, SH2A-FPU)	295
4.2.9	Register Banks (SH-2A, SH2A-FPU)	296
4.3	Using SH2A-FPU, SH-4, or SH-4A	296
4.4	System Reserve	297
4.4.1	Reserved Name	297
4.4.2	Reserved TRAP (Only in HI7000/4)	297
4.5	Tasks	297
4.6	Task Exception Processing Routines	302
4.7	Extended Service Call Routines	306
4.8	Interrupt Handlers	307
4.8.1	Normal Interrupt Handler	307
4.8.2	Direct Interrupt Handler (HI7000/4)	312
4.9	CPU Exception Handler (Including TRAPA Instruction Exception)	323
4.10	Time Event Handlers and Initialization Routine	329
4.11	CPU Initialization Routines	335
4.11.1	Creating CPU Initialization Routines in C language	335
4.11.2	Defining CPU Initialization Routines in HI7000/4	335
4.11.3	Defining CPU Initialization Routines in HI7700/4 and HI7750/4	336
4.12	System Down Routines	336
4.13	Using the DSP in Programs (for HI7000/4 and HI7700/4 only)	337
4.13.1	Initializing DSR	337
4.13.2	Using DSP in Handlers	338

Section 5	Configuration	341
5.1	Read First	341
5.1.1	Whole Linkage and Separate Linkage	341
5.2	Folder Structure	344
5.2.1	hhead Folder	344
5.2.2	hisys Folder	344
5.2.3	hilib Folder	344
5.2.4	kn1 Folder	344
5.2.5	samples\shmmn Folder	344
5.3	Operating Procedure	349
5.4	Configurator	350
5.4.1	Overview	350
5.4.2	Configurator Construction	351
5.4.3	File Operation	352
5.4.4	Configuration Files	352
5.4.5	Separate Linkage	354
5.4.6	Configurator Settings	355
5.5	When Optimized Timer Driver is Used (HI7700/4)	364
5.6	When DSP Standby Control Function is Used (HI7700/4)	364
5.7	When Cache Support Function is Used on SH4AL-DSP (HI7700/4) or SH-4A (HI7750/4)	364
5.8	HEW Workspace and Projects	365
5.9	Kernel Libraries	367
5.9.1	HI7000/4	367
5.9.2	HI7700/4	367
5.9.3	HI7750/4	370
5.10	Section Configuration	371
5.11	Settings Common to All Projects	373
5.11.1	CPU Options for the Compiler and Assembler	373
5.11.2	GBR Option of Compiler (Compiler Package V.7.1 or Later)	373
5.11.3	PACK Option and #pragma pack of Compiler (Compiler Package V.8 or Later)	374
5.11.4	Include Directory for Compiler and Assembler	374
5.11.5	When SH2A-FPU or SH-4 or SH-4A is Used	374
5.11.6	TBR Option of Compiler (Compiler Package V.9 or Later)	374
5.12	Build for Whole Linkage (mix)	375
5.12.1	Adding Files to a Project	375
5.12.2	Defining Endian	375
5.12.3	Setting Optimized Linkage Editor Options	376
5.12.4	Executing a Build	379
5.13	Build for Separate Linkage: Kernel Side (def)	380
5.13.1	Adding Files to a Project	380
5.13.2	Defining Endian (HI7700/4 and HI7750/4)	380
5.13.3	Setting Optimized Linkage Editor Options	381
5.13.4	Executing a Build	384
5.14	Build at Separate Linkage: Kernel Environment Side (cfg)	385
5.14.1	Adding Files to a Project	385
5.14.2	Defining Endian (HI7700/4 and HI7750/4)	385
5.14.3	Setting Optimized Linkage Editor Options	386
5.14.4	Executing a Build	388
5.15	Application Load Module Creation	388

Appendix A	Service Call List	389
Appendix B	Error List.....	401
B.1	Service Call Error Code List	401
B.2	Information during System Down	402
B.3	Error during Compiling	403
B.3.1	Error when Files are for a Different HI7000/4 Series.....	403
B.3.2	Errors to Do with the Optimized Timer Driver (HI7700/4).....	403
B.3.3	Errors to Do with the DSP-Standby Control Function (HI7700/4)	404
Appendix C	Calculation of Work Area Size.....	405
C.1	Work Areas	405
C.2	Stack Types	406
C.3	Stack Size Calculation Procedure.....	407
C.4	Calculation of Stack Size for Each Function	408
C.5	Stack Size Considering Programming Nesting.....	409
C.6	Task Stacks.....	411
C.6.1	Stack Size Used by Each Task.....	411
C.6.2	Stack Area Acquisition.....	412
C.7	Interrupt Handler Stacks.....	413
C.7.1	Stack Size Used by an Interrupt Handler.....	413
C.7.2	Stack Area Allocation	414
C.8	Stack Size Used by a Time Event Handler and Timer Interrupt Routine	415
C.9	Initialization Routine Stacks.....	417
C.10	Timer Initialization Routine Stack	418
Appendix D	Timer Driver	419
D.1	Overview	419
D.2	Standard Timer Driver.....	419
D.2.1	Installing the Time Management Function.....	419
D.2.2	Sample Timer Driver.....	421
Appendix E	Optimized Timer Driver (HI7700/4).....	423
E.1	Overview	423
E.2	Operation.....	423
E.3	Applicable MCUs.....	425
E.4	Hardware Initialization.....	425
E.5	Differences with the Standard Timer Driver	425
E.6	Ways to Include Optimized Timer Driver	426
E.6.1	Overview	426
E.6.2	Creating the kernel_def_opttmr_set.h Definition File	426
E.6.3	Notes on the Configurator	427
E.6.4	Modifying kernel_sys.h.....	428
E.7	Kernel Libraries to be Used.....	428
Appendix F	DSP Standby Control (HI7700/4).....	429
F.1	Overview	429
F.2	Applicable MCUs.....	431
F.3	Module-Standby State when Initiating Programs.....	431

F.4	Service Call for Changing the TA_COP0 Attribute (vchg_cop).....	432
F.5	Ways to Include DSP Standby Control Function.....	433
F.5.1	Overview.....	433
F.5.2	Creating the kernel_def_dspstby_set.h Definition File.....	433
F.5.3	Modifying kernel_sys.h.....	435
F.6	Kernel Libraries to be Used.....	435
F.7	Notes.....	435
Appendix G Notes on FPU of SH2A-FPU, SH-4, SH4A		437
G.1	Task and Task Exception Processing Routine.....	437
G.1.1	Initialization of FPSCR.....	437
G.1.2	Attributes TA_COP1 and TA_COP2.....	438
G.2	Non-Task Context (Normal Interrupt Handler, Direct Interrupt Handler, CPU Exception Handler, Time Event Handler, Initialization Routine).....	438
G.2.1	Overview.....	438
G.2.2	SH-4, SH-4A.....	439
G.2.3	SH2A-FPU.....	441
G.3	Extended Service Call Routine.....	441
G.3.1	Compiler Options.....	441
G.3.2	Called from Task Context.....	442
G.3.3	Called from Non-Task Context.....	442
G.4	Information for Reference.....	443
G.4.1	States on the Initiation of Tasks and Handlers.....	443
G.4.2	FPSCR Structure.....	444
G.4.3	Handling by the Compiler.....	445
Appendix H New Functions of HI7000/4 V.2.....		447
H.1	Support of SH-2A and SH2A-FPU.....	447
H.1.1	FPU (SH2A-FPU) (V.2.00 Release 00).....	447
H.1.2	TBR Register (V.2.00 Release 00).....	447
H.1.3	Register Banks (V.2.00 Release 00, V.2.01 Release 00 and V.2.02 Release 00).....	448
H.2	Specifying Address of Task Stack, Fixed-Size Memory Pool, and Variable- Size Memory Pool (V.2.00 Release 00).....	448
H.3	Management Method of Fixed-Size Memory Pool (V.2.00 Release 00).....	449
H.4	Direct Interrupt Handler (V.2.00 Release 00 and V.2.02 Release 00).....	450
H.5	Macros for Calculating Size (V.2.00 Release 00).....	450
H.6	Extension of Maximum Vector Number (V.2.00 Release 00).....	450
H.7	ID Name (V.2.00 Release 00).....	451
H.8	Support of Little Endian in SH-2 (V.2.00 Release 01).....	451
H.9	Improvement of Variable-Size Memory Pool (V.2.01 Release 00).....	451
H.10	Initial Value of DSR (V.2.01 Release 00).....	452
H.11	Initial Value of SR in Task Exception Processing Routine (V.2.01 Release 00).....	452
H.12	Handling of Vector Numbers 16 to 31 (V.2.01 Release 00).....	452
H.13	Lifting of Restriction concerning Structure Alignment (V.2.01 Release 00).....	453
H.14	[Open the file used last time] Command for the Configurator (V.2.02 Release 00).....	453
Appendix I New Functions of HI7700/4 V.2.....		455
I.1	Support of SH4AL-DSP (with Extended Function) (V.2.01 Release 00).....	455

I.2	Specifying Address of Task Stack, Fixed-Size Memory Pool, and Variable-Size Memory Pool (V.2.01 Release 00)	455
I.3	Management Method of Fixed-Size Memory Pool (V.2.01 Release 00)	455
I.4	Improvement of Variable-Size Memory Pool (V.2.01 Release 00).....	457
I.5	Macros for Calculating Size (V.2.01 Release 00)	458
I.6	Initial Value of DSR (V.2.01 Release 00)	458
I.7	Initial Value of SR in Task Exception Processing Routine (V.2.01 Release 00)	459
I.8	Extension of Maximum Exception Code (CFG_MAXVCTNO) (V.2.01 Release 00)	459
I.9	Handling of TRAPA #16 to #31 (V.2.01 Release 00)	459
I.10	Release of Restriction concerning Structure Alignment (V.2.01 Release 00).....	459
I.11	ID Name (V.2.01 Release 00)	460
I.12	[Open the file used last time] Command for the Configurator (V.2.02 Release 00)	460
Appendix J New Functions of HI7750/4 V.2.....		461
J.1	Support of SH-4A (with Extended Function) (V.2.01 Release 00)	461
J.2	Specifying Address of Task Stack, Fixed-Size Memory Pool, and Variable-Size Memory Pool (V.2.01 Release 00)	461
J.3	Management Method of Fixed-Size Memory Pool (V.2.01 Release 00)	461
J.4	Improvement of Variable-Size Memory Pool (V.2.01 Release 00).....	463
J.5	Macros for Calculating Size (V.2.01 Release 00)	464
J.6	Initial Value of SR in Task Exception Processing Routine (V.2.01 Release 00 or Later).....	464
J.7	Extension of Maximum Exception Code (CFG_MAXVCTNO) (V.2.01 Release 00)	464
J.8	Handling of TRAPA #16 to #31 (V.2.01 Release 00)	465
J.9	Release of Restriction concerning Structure Alignment (V.2.01 Release 00).....	465
J.10	ID Name (V.2.01 Release 00)	465
J.11	[Open the file used last time] Command for the Configurator (V.2.02 Release 00)	465

Section 1 Introduction

1.1 Overview

Operating systems (OSs) for system development have grown with the ever-increasing use of microcomputer systems in a wide variety of fields. In particular, realtime OSs have gained wide acceptance for use in industrial measurement and control systems.

1.2 Features

The HI7000/4 series kernel is based on the μ ITRON4.0 specifications. Features of the kernel are outlined below.

- Comprehensive functions for realtime and multitasking processing
- Priority-based task scheduling
- Task management, including the creation, deletion, initiation, and termination of tasks
- Task synchronization, including suspension and resumption of tasks, and task event flags
- Task exception processing functions, including the definition, request, enabling, and disabling of task exception processing
- Extended inter-task synchronization and communication using semaphores, event flags, data queues, and mailboxes
- Inter-task synchronization and communication using mutexes and message buffers
- Memory pool management, including control over the allocation and return of memory blocks
- Control over timing, such as setting and referring to the system clock, and controlling the cyclic handler, alarm handler, and overrun handler
- System management
- Interrupt management
- Service call management, including the definition and issue
- System configuration management, including the definition of CPU exception handlers
- Support of DSP and FPU (note that the HI7000/4 does not support the FPU in the SH-2E processor)
- Cache support function (only for HI7700/4 and HI7750/4)
- Optimized timer driver and DSP standby control function for low-power consumption (only for HI7700/4)
- A compact kernel with optional selection of kernel functions

The size of the kernel program and size of its work area are reduced to minimize the ROM and RAM size required by the user system. The kernel optimized for the user system can be configured by selecting the kernel functions to be used by the user system.

- Sample programs

The following sample source programs are provided. By modifying the programs as required, the user system can easily be created and customized for the user.

Section1 Introduction

- System down routine
- Timer driver for on-chip timers of SuperH™ microcomputer series
- CPU initialization routine
- Section initialization and definition file

- Configurator

The configurator is supported to ease kernel configuration.

- Debugging extension (option)

The debugging extension which adds a multitasking debugging function to HEW3 or later versions of HEW is prepared. The debugging extension supports the following functions.

- Refer to the status of objects, such as a task
- Operate to objects, such as starting task, or set event flag
- Display service call history

The debugging extension can be downloaded free of charge from our homepage.

1.3 Operating Environment

The operating environment is shown in table 1.1.

Table 1.1 Operating Environment

Product Name	Files Included	Operating Environment
HI7000/4	Kernel	All SuperH™ microcomputers incorporating SH-1, SH-2, SH2-DSP, SH-2A, or SH2A-FPU
	Sample program	Some SuperH™ microcomputers incorporating SH-1, SH-2, SH2-DSP, SH-2A, or SH2A-FPU
	Sample HEW workspace and project	HEW version 1.2 or later (SuperH™ RISC engine C/C++ compiler package version 6.0C or later)
	Configurator	Windows® 98, Windows® Millennium Edition (Windows® Me), WindowsNT® 4.0, Windows® 2000, and Windows® XP
HI7700/4	Kernel	All SuperH™ microcomputers incorporating SH-3, SH3-DSP, or SH4AL-DSP
	Sample program	Some SuperH™ microcomputers incorporating SH-3, SH3-DSP, or SH4AL-DSP
	Sample HEW workspace and project	HEW version 1.2 or later (SuperH™ RISC engine C/C++ compiler package version 6.0C or later)
	Configurator	Windows® 98, Windows® Millennium Edition (Windows® Me), WindowsNT® 4.0, Windows® 2000, and Windows® XP
HI7750/4	Kernel	All SuperH™ microcomputers incorporating SH-4 or SH-4A
	Sample program	Some SuperH™ microcomputers incorporating SH-4 or SH-4A
	Sample HEW workspace and project	HEW version 1.2 or later (SuperH™ RISC engine C/C++ compiler package version 6.0C or later)
	Configurator	Windows® 98, Windows® Millennium Edition (Windows® Me), WindowsNT® 4.0, Windows® 2000, and Windows® XP

1.4 Installation

Refer to release notes attached to the product.

1.5 Target Product of This Manual

- HI7000/4: V.2.02 Release 00 or later
- HI7700/4: V.2.02 Release 00 or later
- HI7750/4: V.2.02 Release 00 or later

Section 2 Kernel

2.1 Overview

The kernel, which is the nucleus of the operating system, enables realtime multitasking. It has three major roles.

- **Response to events**
Recognizes events generated asynchronously, and immediately executes a task to process the event.
- **Task scheduling**
Schedules task execution on a priority basis.
- **Service call execution**
Accepts various requests for processing (service calls) from tasks and performs the appropriate processing.

2.2 Functions

An application program can issue service calls to almost any kernel function.

Task Management: When a task is executed, the CPU is allocated to the task. The kernel controls the order of CPU allocation, and of the start and end of tasks. Multiple tasks can share one stack by using the shared-stack function.

Task Synchronization Management: Performs basic synchronous processing for tasks, such as suspension of task execution, resumption, and task event flag processing.

Synchronization and Communication Management: Uses event flags, semaphores, data queues, and mailboxes for inter-task synchronization and communication.

Extended Synchronization and Communication Management: Uses mutex and message buffers for inter-task synchronization and communication.

Memory Pool Management: Manages unused memory in the user system as a memory pool. A task dynamically acquires blocks from or returns them to the memory pool. The size of the memory pool can be fixed or variable.

Time Management: Manages time-related information for the system and monitors task execution times for control purposes.

System State Management: Performs system state management functions, such as modifying or referencing the context or system states.

Interrupt Management: Initiates the appropriate interrupt handlers in response to external interrupts. The interrupt handler performs appropriate interrupt processing, and notifies tasks of interrupts.

Service Call Management: Defines or calls an extended service call.

System Configuration Management: Performs system configuration management functions, such as defining the CPU exception handlers and reading the kernel version number.

DSP/FPU Support: Supports the DSP and FPU in its multitasking environment. Each task can use special registers to execute DSP/FPU instructions.

2.3 Processing Units and Precedence

An application program is executed in the following processing units.

Task: A task is a unit controlled by multitasking.

Task Exception Processing Routine: A task exception processing routine is executed when a task exception processing is requested by a task in the `ras_tex` service call.

Interrupt Handler: An interrupt handler is executed when an interrupt occurs.

CPU Exception Handler: A CPU exception handler is executed when a CPU exception occurs.

Time Event Handler (Cyclic Handler, Alarm Handler, and Overrun Handler):

A time event handler is executed when a specified cycle or time has been reached.

Extended Service Call: An extended service call is used to call a module that is not linked. When this extended service call is issued, the corresponding extended service call routine is called.

Each processing unit is processed with the following precedence.

- (1) Interrupt handlers, time event handlers and CPU exception handlers
- (2) Dispatcher (part of kernel processing)
- (3) Tasks

The dispatcher is a kernel processing that switches a task to be executed.

The precedence of an interrupt handler becomes higher when an interrupt level is higher.

The precedence of a time event handler is the same as a timer interrupt level (`CFG_TIMINTLVL`).

The precedence of a CPU exception handler is higher than that of the processing where the CPU exception occurred and of the dispatcher. The precedence of a CPU exception handler is also lower than that of other processings which have the higher precedence than those where the CPU exception occurred.

The precedence between tasks depends on the priority of these tasks.

The precedence of an extended service call routine is higher than that of the processing where the extended service call was called. The precedence of an extended service call routine is also lower than that of other processings which have the higher precedence than those where the extended service call was called.

The precedence of a task's exception processing routine is higher than that of the task and lower than that of other higher-level tasks.

When the following service calls are called, the precedence which does not apply above can be temporarily generated:

- (a) When `dis_dsp` is called, the precedence will be the middle of (1) and (2) above. The state returns to former state by calling `dis_dsp`.
- (b) When `loc_cpu` or `iloc_cpu` is called, the precedence will be the same as that of the interrupt handler of which interrupt level is the same as `CFG_KNLMSKLVL`. The state returns to former state by calling `unl_cpu` or `iunl_cpu`.
- (c) While the interrupt mask level is changed to other than 0 by `chg_ims`, the precedence is the same as an interrupt handler which has the same level.

2.4 System State

The system state is classified into the following orthogonal states.

- Task context state/non-task context state
- Dispatch-disabled state/dispatch-enabled state
- CPU-locked state/CPU-unlocked state

The system operations and available service calls are determined based on the above system states.

2.4.1 Task Context State and Non-Task Context State

The system is executed in either task context state or non-task context state. The difference between task and non-task context states is described in table 2.1.

Table 2.1 Task Context State and Non-Task Context State

Item	Task Context State	Non-Task Context State
Available service calls	Service calls that can be called from the task context	Service calls that can be called from the task context
Task scheduling	Refer to sections 2.4.2 and 2.4.3	Does not occur

The following processing is executed in non-task context.

- Interrupt handler
- CPU exception handler
- Time event handler (cyclic handler, alarm handler, and overrun handler)
- A part where the interrupt mask is changed to a value other than 0 by the `chg_ims` service call

Note that extended service calls initiated in the above processing state are also executed in non-task context.

2.4.2 Dispatch-Disabled State/Dispatch-Enabled State

The system is placed in either dispatch-disabled state or dispatch-enabled state. In dispatch-disabled state, task scheduling is not allowed and service calls that place a task in the WAITING state cannot be used.

Issuing the `dis_dsp` service call during task execution changes the system state to dispatch-disabled state. Issuing the `ena_dsp` service call will return the system state to the dispatch-enabled state. Issuing the `sns_dsp` service call will check whether the system state is in dispatch-disabled state or not.

2.4.3 CPU-Locked State/CPU-Unlocked State

The system is placed in either CPU-locked state or CPU-Unlocked state. In CPU-locked state, interrupts and task scheduling are not allowed. Note, however, that interrupts with interrupt mask levels higher than that specified in the kernel mask level (CFG_KNLMSKLVL) in configuration are allowed. In this state, service calls that place a task in the WAITING state cannot be used.

Issuing the `loc_cpu` or `iloc_cpu` service call during task execution changes the system state to CPU-locked state. Issuing an `unl_cpu` or `iunl_cpu` will return the system state to the CPU-unlocked state. In addition, issuing the `sns_loc` service call will check whether the system state is in CPU-locked state or not.

In the CPU-locked state, service calls than can be issued are restricted as described in 3.2.5, System State and Service Calls.

2.5 Objects

Objects such as tasks and semaphores are manipulated by service calls. Objects are identified by ID numbers or object numbers. The maximum number can be specified for almost all objects in configuration.

2.6 Tasks

In a realtime multitasking system, the user prepares an application program in terms of a set of tasks that can be processed independently and in parallel.

A task communicates with other tasks by using service calls. Such service calls can be used to have the kernel process events that are asynchronously generated by external devices or by the MCU.

Tables 2.2 and 2.3 list the service calls that operate tasks.

Table 2.2 Task-Management Service Calls

Service Call	Description
cre_tsk, icre_tsk	Creates task (using dynamic stack)
vscr_tsk, ivscr_tsk	Creates task (using static stack)
acre_tsk, iacre_tsk	Creates task (automatically assigns task ID)
del_tsk	Deletes task
act_tsk, iact_tsk	Starts task
can_act, ican_act	Cancel start task request
sta_tsk, ista_tsk	Starts task (specifies start task code)
ext_tsk;	Exits current task
exd_tsk	Exits current task and deletes it
ter_tsk	Forcibly terminates a task
chg_pri, ichg_pri	Changes task priority
get_pri, iget_pri	Refers to task priority
ref_tsk, iref_tsk	Refers to task state
ref_tst, iref_tst	Refers to task state (simple version)
vchg_tmd	Changes task execution mode

Table 2.3 Task Synchronization Service Calls

Service Call	Description
slp_tsk	Sleep task
tslp_tsk	Sleep task with timeout
wup_tsk, iwup_tsk	Wakeup task
can_wup, ican_wup	Cancel wakeup task
rel_wai, irel_wai	Release WAITING state forcibly
sus_tsk, isus_tsk	Suspend task
rsm_tsk, irsm_tsk	Resume task
frsm_tsk, ifrsm_tsk	Resume task forcibly
dly_tsk	Delay task

2.6.1 Task State and Transition

A task can be in any of the following seven states in the user system.

NON-EXISTENT State: A task has not been registered in the kernel and has been in a virtual state.

DORMANT State: A task has been registered in the kernel but has not yet been initiated, or has already been terminated.

READY (executable) State: An executable task is in the queue is waiting for CPU resource allocation because another higher priority task is currently running.

RUNNING State: The task is currently running. The kernel puts the READY task with the highest priority in the RUNNING state.

WAITING State: A task issues a service call such as `tslp_tsk` to put itself to sleep when it can no longer continue execution. The task is released (awakened) from the WAITING (sleep) state when the service call `wup_tsk` is issued, and it then makes the transition to the READY state.

SUSPENDED State: A task has been suspended by another task by `sus_tsk`.

WAITING-SUSPENDED State: This state is a combination of the WAITING state and SUSPENDED state.

Figure 2.1 shows the task-state transition diagram.

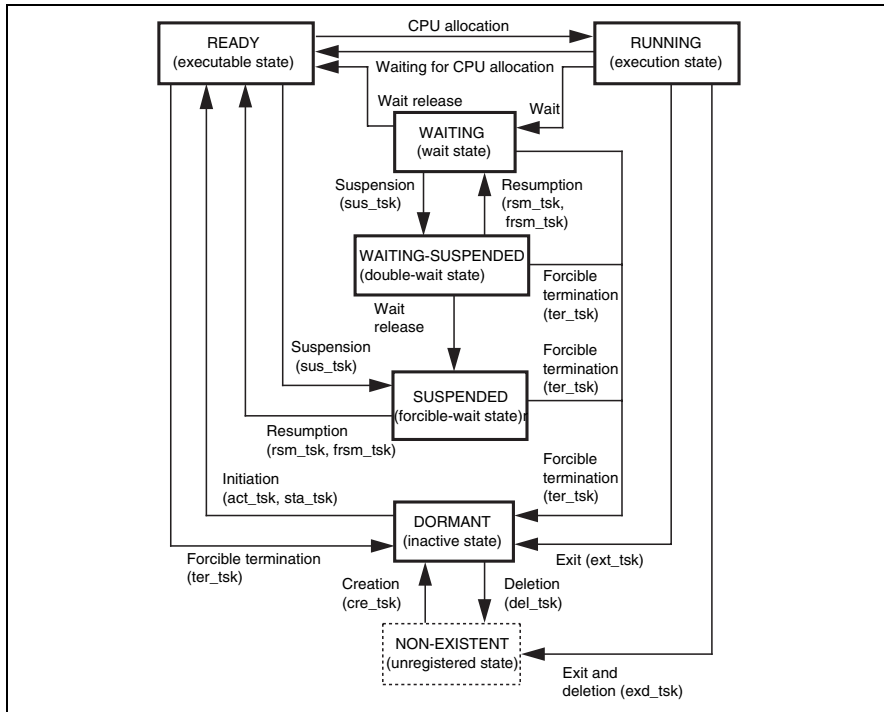

Figure 2.1 Task State Transition Diagram

2.6.2 Task Creation

Task creation means that a NON-EXISTENT task becomes DORMANT. The method of creating a task differs depending on the stack type used by the task to be created. For details, refer to section 0,

Task Stack. The methods of creating a task are shown in table 2.4.

Table 2.4 Task Creating Methods

Task Creating Method	Stack Type Used by Created Task		
	Static Stack	Dynamic Stack	Stack Allocated by Application
cre_tsk, acre_tsk service calls		✓	✓
vscr_tsk service call	✓		
Configurator	✓	✓	✓

2.6.3 Task Initiation

A task is initiated when it moves from the DORMANT state to become READY. A task can be initiated by one of two methods:

- By issuing the act_tsk or sta_tsk service calls for the target task
- By specifying TA_ACT as a task attribute when a task is created

The kernel performs the following processing at task initiation.

- Initialize the task base priority and current priority
- Clear the number of task wake-up requests
- Clear the number of nestings of task suspension requests
- Clear the pending task exception sources
- Set task exception processing to the disabled state
- Set the task event flag to 0

The following parameter is passed to the task.

- (1) When TA_ACT attribute is specified at task creation and when the task is started by act_tsk service call
The extended information (exinf) which is specified at task creation is passed to the task.
- (2) When the task is started by sta_tsk service call
The task start code (stacd) which is specified by sta_tsk service call is passed to the task.

2.6.4 Task Scheduling

Scheduling: For each task, a task priority is assigned to determine the priority of processing. A smaller value indicates a higher priority level and level 1 is the highest priority.

The kernel selects the highest-priority task from the READY tasks and puts it in the RUNNING state.

The same priority can be assigned for multiple tasks. When there are multiple READY tasks with the highest priority, the kernel selects the first task that became READY and puts it in the RUNNING state. To implement this behavior, the kernel has ready queues, which are READY task queues waiting for execution.

While execution is in a non-task context, no task is executed until the non-task context processing is completed.

Round-Robin Scheduling: The kernel also supports round-robin scheduling, where the CPU allocates equal time to tasks with a given priority by rotating the ready queue at specific intervals. The round-robin scheduling can be achieved by issuing the `rot_rdq` service call that manipulates the ready queues.

- Round-Robin Scheduling with `rot_rdq` Service call
By issuing `rot_rdq` at specific cycles, execution can be switched at specific intervals to a task that has the same priority as the executing task.

Limitations to Scheduling: When the system enters the dispatch-disabled state by the `dis_dsp` service call, task scheduling is disabled. Task scheduling is enabled when the system enters the dispatch-enabled state by the `ena_dsp` service call.

When the system enters the CPU-locked state by the `loc_cpu` service call, both task scheduling and all interrupts other than kernel management interrupts are disabled. Task scheduling and interrupts are enabled when the system enters the CPU-unlocked state by the `unl_cpu` service call.

2.6.5 Task Termination and Deletion

Task termination means that a task is finished and can enter the DORMANT or NON-EXISTENT state.

- ext_tsk is issued
- exd_tsk is issued
- ter_tsk is issued to the target task

When a task is terminated and then re-initiated, or when the number of initiation request queues specified in the act_tsk service call is other than 0, the task starts from the initial state.

When a task will no longer be used or when re-assigning the task ID to another task or, the exd_tsk service call is issued and the task is made NON-EXISTENT. The ID can now be assigned to another task. A task must release its resources before execution can be completed. Note that the mutex is unlocked when a task is terminated and deleted.

The kernel performs the following processing when a task is terminated:

- Unlock the mutex that is locked by the current task
- Clear the upper limit processor time

The kernel performs the following processing when a task is deleted:

- Release the task stack area

2.6.6 Task Stack

There are three methods of allocating stacks.

Static Stack: The static stack is defined for each task by the configurator when the system is configured. A shared stack function, which allows more than one task to use a single stack, is available for tasks that use the static stack.

Dynamic Stack: When a task is created, the kernel assigns a stack area to the task. The stack is allocated in the dynamic stack area (CFG_TSKSTKSZ). A shared stack function is not available for tasks that use a dynamic stack.

Stack Allocated by Application: The application allocates a stack area and specifies the address at task creation. A shared stack function is not available for tasks that use this type of stack.

The configurator specifies the maximum task ID (CFG_STSTKID), which represents the maximum ID of a task using the static stack, and the maximum task ID (CFG_MAXTSKID) in the system. Tasks with task IDs between 1 and CFG_STSTKID use the static stack, while tasks with task IDs between CFG_STSTKID + 1 and CFG_MAXTSKID use the dynamic stack or stack allocated by application. If CFG_STSTKID is specified as 0, no static stack is used. If CFG_STSTKID and CFG_MAXTSKID are specified as the same value, all tasks use the static stack.

2.6.7 Shared Stack Function

More than one task can share one static stack. This reduces the total stack area. The shared stack function is not defined in the μ ITRON4.0 specification.

Shared stack and static stack assignment is defined by the configurator. However, only one task in a task group that shares a stack can be executed at a time. When multiple tasks are initiated and share a stack, the task that was initiated first uses the stack first. The remaining tasks enter the shared-stack wait state. Tasks in the shared-stack wait state are managed as a first-in first-out (FIFO) queue, regardless of their priority. Tasks are sent to the shared-stack wait queue in the order in which they were initiated.

A shared stack is released from the task when the task becomes DORMANT. When tasks are waiting for the shared stack, the task at the head of the wait queue will use the stack, and enters the READY state.

Figure 2.2 shows the task-state transitions for the shared stack function.

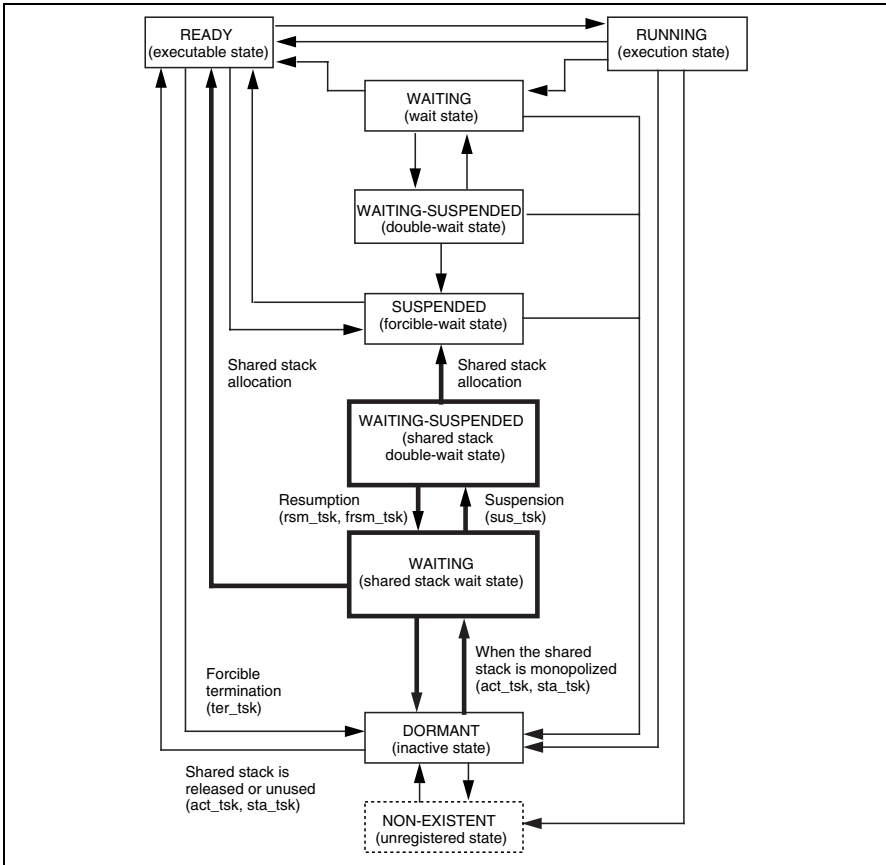

Figure 2.2 Task-State Transitions for the Shared Stack Function

2.6.8 Task Execution Mode

In some cases, one task may force another task to terminate (by issuing `ter_tsk`) before the other task releases the resources it has been using. In addition, one task may forcibly be terminated at an inappropriate time by issuing the `sus_tsk` service call.

To mask requests issued by `ter_tsk` or `sus_tsk` service calls, use the `vchg_tmd` service call.

2.6.9 Exclusive Control

In some cases, during execution of one task, the task may need to be executed exclusively with another program. For example, when task A and interrupt handler B refer to and modify the same global variable, reference and modification must be exclusive. The target program to control exclusivity can be an interrupt handler, specific task, or any other task.

Table 2.5 shows the way to ensure that tasks execute exclusively.

Table 2.5 Exclusive Control

Exclusive Control	Inhibited Interrupts	Task Scheduling
Enter the CPU-locked state by issuing <code>loc_cpu</code>	Equal to or lower than the kernel interrupt mask level (<code>CFG_KNLMSKLVL</code>)	None
Mask interrupts by issuing <code>chg_ims</code> service call (When the <code>chg_ims</code> service call is issued from the task context state, the execution becomes the non-task context state)	Equal to or lower than the specified mask level	None
Enter disabled-dispatch state by issuing <code>dis_dsp</code> service call	None	None
Exclusive control by semaphore	None	The kernel schedules tasks; however, in tasks using the same semaphore, the number of tasks entering the READY state simultaneously is limited to the semaphore initial count value.
Exclusive control by mutex	None	The kernel schedules tasks; however, tasks using the same mutex cannot enter the READY state simultaneously. In addition, in tasks using the same mutex, the task priority inversion will not occur.

2.6.10 Task Event Flags

Task event flags are a bit patterns for tasks. A task can wait for a specified bit to be set in the task event flag for the current task; that is, it can wait until the specified event occurs.

Task event flags are controlled by the service calls listed in table 2.6.

Table 2.6 Service Calls for Task Event Flag Control

Service Call Name	Description
vset_tfl, ivset_tfl	Sets task event flag
vclr_tfl, ivclr_tfl	Clears the event flag
vwai_tfl	Waits for event occurrence
vpoll_tfl	Polls for event occurrence
vtwai_tfl	Waits for event to occur, with timeout

Figure 2.3 shows an example of the using task event flags.

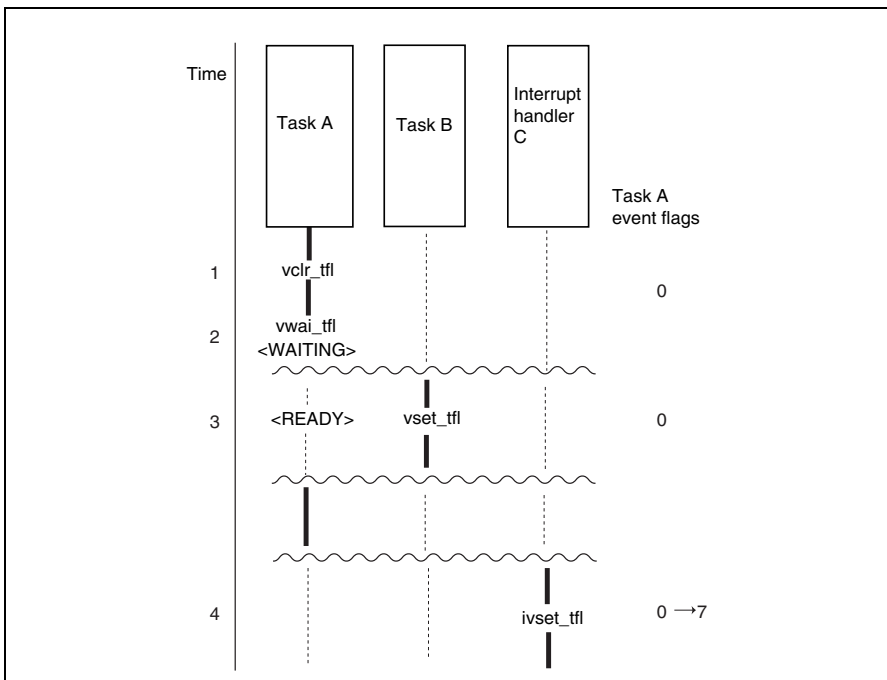

Figure 2.3 Example of Using Task Event Flag

Description:

The bold lines indicate executed processing, and the following describes the task event flag operation with respect to time.

1. Task A issues `vclr_tfl` to clear all bits in its task event flag.
2. Task A issues `vwai_tfl` (waiting pattern = `H'ffffff`) to wait for an event.
3. Task B issues `vset_tfl` (set pattern = 1) to task A. Since this set pattern is included in the waiting pattern specified in task A, the WAITING state of task A is cancelled and the task A event flags are cleared to 0.
4. Interrupt handler C issues `ivset_tfl` (set pattern = 7) to set event flags of the task A. In this case, however, task A does not wait for an event, therefore the task event flags are logically ORed with a pattern specified by `vset_tfl`.

2.7 Task Exception Processing

Task exception processing is performed when an exception occurs during task execution. Task exception processing is performed asynchronously with task processing and is similar to the function generally called "signal".

Task exception processing is controlled by the service calls listed in table 2.7.

Table 2.7 Service Calls for Task Exception Processing

Service Call Name	Function
<code>def_tex, idef_tex</code>	Defines a task exception processing routine
<code>ras_tex, iras_tex</code>	Requests task exception processing
<code>dis_tex</code>	Disables task exception processing
<code>ena_tex</code>	Enables task exception processing
<code>sns_tex</code>	Refers to the task exception disable state
<code>ref_tex, iref_tex</code>	Refers to the task exception processing state

Task exception processing routines can also be defined by the configurator. Figure 2.4 shows an example of task exception processing.

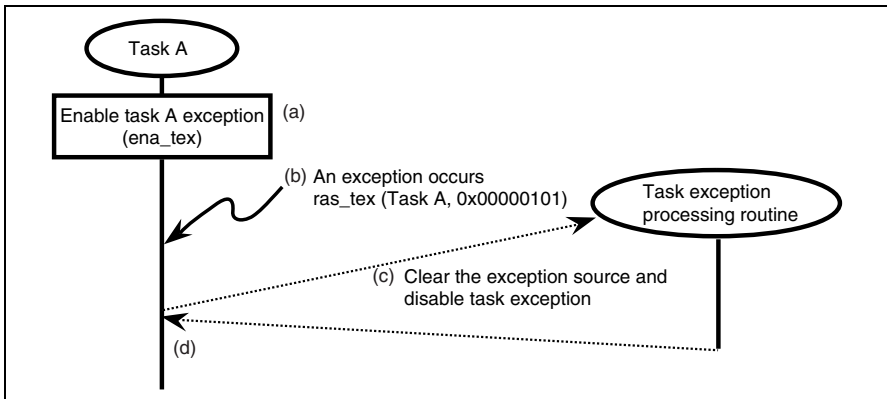

Figure 2.4 Example of Task Exception Processing

Description (Letters indicate the order of operation):

- (a) Task A enables a task exception.
- (b) An exception (exception factor = 00000101) is requested from task A via the ras_tex service call during task A execution.
- (c) When task A is scheduled to execute, task exception processing is initiated before the task A main routine is executed. During task exception processing, the task enters the task exception processing disabled state and the task exception source is cleared.
- (d) After returning from the task exception processing routine, the task A main routine is resumed.

2.8 Semaphore

The elements required for task execution are called resources. They include the memory shared between tasks and hardware, like I/O. A semaphore is an object, and provides exclusive control and a synchronization function by expressing the existence and the number of resources by a counter. In this case, tasks must be created in order to separate a region of a task that are to be exclusively accessed using `wai_sem` and `sig_sem` service calls. Usually, the number of resources that can be used is the number of resources initially defined.

The semaphores are controlled by the service calls listed in table 2.8.

Table 2.8 Service Calls for Semaphore Control

Service Call Name	Function
<code>cre_sem</code> , <code>icre_sem</code>	Creates a semaphore
<code>acre_sem</code> , <code>iacre_sem</code>	Creates a semaphore (automatically assigns ID)
<code>del_sem</code>	Deletes a semaphore
<code>sig_sem</code> , <code>isig_sem</code>	Releases a resource
<code>wai_sem</code>	Acquires a resource
<code>pol_sem</code> , <code>ipol_sem</code>	Polls and gets a resource
<code>twai_sem</code>	Requests resource allocation with timeout
<code>ref_sem</code> , <code>iref_sem</code>	Refers to the semaphore state

Semaphores can also be created by the configurator. Figure 2.5 shows an example of using semaphore.

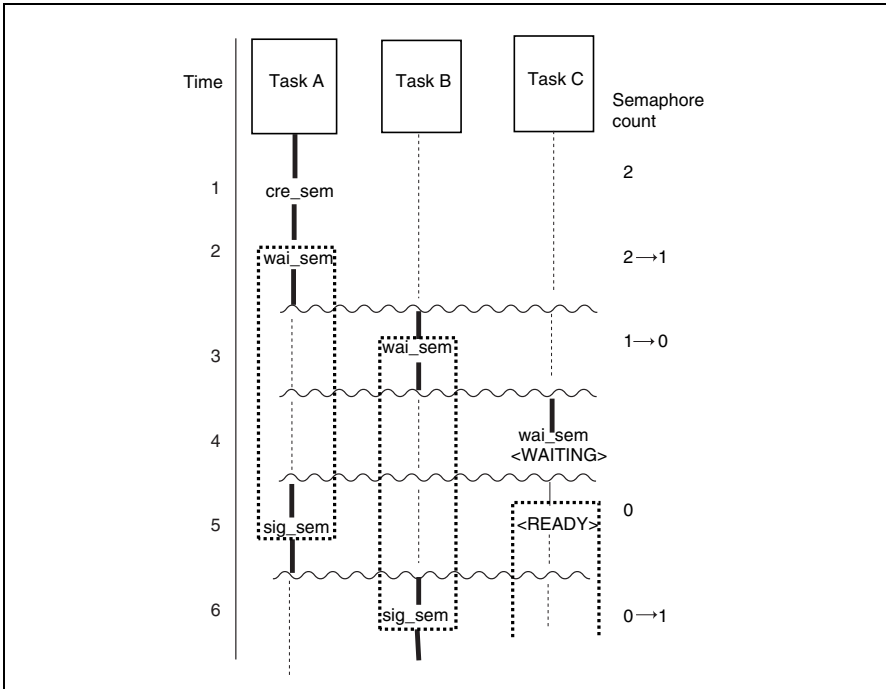

Figure 2.5 Example of Using Semaphore

Description:

Bold lines represent executed processing, and dotted lines represent the region where tasks can exclusively access resources. The following describes the semaphore operation with respect to time.

1. Task A creates semaphores by `cre_sem`. The initial value is 2 (semaphore counter = 2).
2. Task A issues `wai_sem` and gets a semaphore, decrementing the semaphore count by 1 (semaphore counter = 1). Task A continues execution.
3. Task B issues `wai_sem`.
4. Task C issues `wai_sem`, but cannot get a semaphore because the semaphore counter is 0, and it enters the `WAITING` state.
5. Task A releases a semaphore by issuing `sig_sem`. The released semaphore is allocated to task C, and task C is released from the `WAITING` state.
6. Task B releases a semaphore by issuing `sig_sem`. There is no task waiting for a semaphore, and so the semaphore counter is incremented by 1.

2.9 Event Flag

An event flag is a bit-group corresponding to events. One event corresponds to one bit. More than one task can wait for a specified bit to be set in an event flag, that is, tasks can wait until the specified event occurs.

Table 2.9 shows the service calls for event flag control.

Table 2.9 Service Calls for Event Flag Control

Service Call Name	Description
cre_flg, icre_flg	Creates an event flag
acre_flg, iacre_flg	Creates an event flag (automatically assigns ID)
del_flg	Deletes an event flag
set_flg, iset_flg	Sets an event flag
clr_flg, iclr_flg	Clears an event flag
wai_flg	Waits for event occurrence
pol_flg, ipol_flg	Waits for event occurrence (polling)
twai_flg	Waits for event occurrence with timeout
ref_flg, iref_flg	Refers to the event flag status

Event flags can also be created by the configurator. Figure 2.6 shows an example of using event flags.

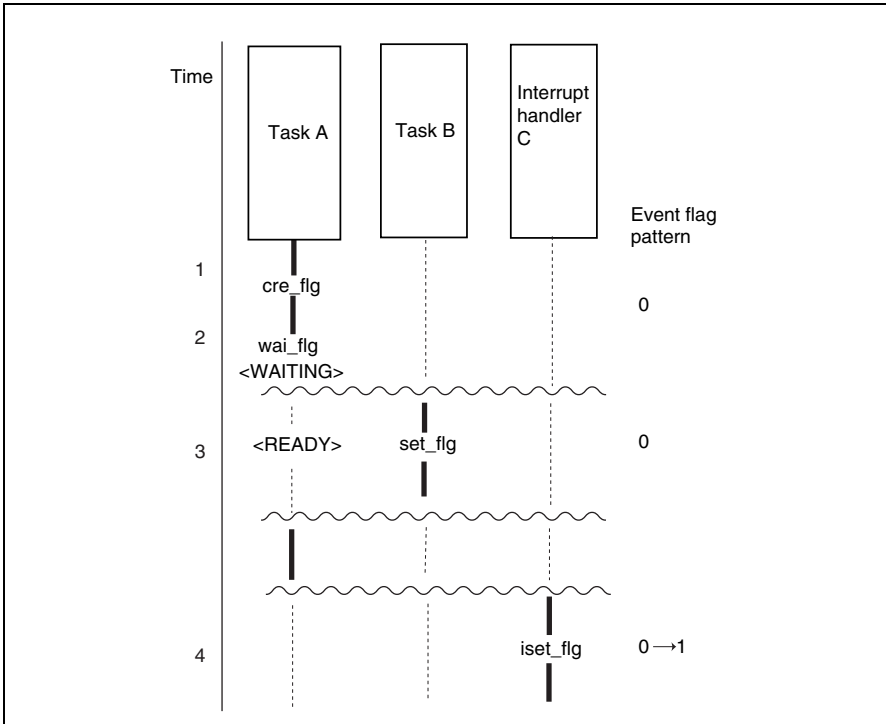

Figure 2.6 Example of Using an Event Flag

Description:

Bold lines represent executed processing. The following describes event flag operation with respect to time.

1. Task A issues `cre_flg` to create an event flag. The `TA_CLR` attribute (clear event flag to 0 when the WAITING state is released) is specified and the initial pattern is specified as 0.
2. Task A issues `wai_flg` (waiting pattern = 3, AND wait) to wait for an event.
3. Task B issues `set_flg` (set pattern = 7). Since all bits that task A was waiting for have been set, task A is released from the WAITING state. In addition, since the `TA_CLR` attribute has been specified, the event flag is cleared to 0.
4. Interrupt handler C sets the event flag by issuing `iset_flg` (set pattern = 1). In this case there is no task waiting for an event, and the event flag is ORed with the pattern specified by `iset_flg`.

2.10 Data Queue

A data queue is used to send or receive 1-word data (4-byte data) between tasks. High-speed data communication can be achieved using a data queue, as communication using a data queue copies 1-word data itself. In addition, pointers can also be specified as data.

The area of each data queue is allocated in the data queue area (CFG_DTQSZ) specified through the configurator.

The data queues are controlled by the service calls listed in table 2.10.

Table 2.10 Service Calls for Data Queue Control

Service Call Name	Function
cre_dtq, icre_dtq	Creates a data queue
acre_dtq, iacre_dtq	Creates a data queue (automatically assigns ID)
del_dtq	Deletes a data queue
snd_dtq	Sends data to a data queue
psnd_dtq, ipsnd_dtq	Sends data to a data queue (polling)
tsnd_dtq	Sends data to a data queue (with timeout)
fsnd_dtq, ifsnd_dtq	Forcibly sends data to a data queue
rcv_dtq	Receives data from a data queue
prcv_dtq	Receives data from a data queue (polling)
trcv_dtq	Receives data from a data queue (with timeout)
ref_dtq, iref_dtq	Refers to the data queue state

Data queues can also be created by the configurator. Figure 2.7 shows an example of using a data queue.

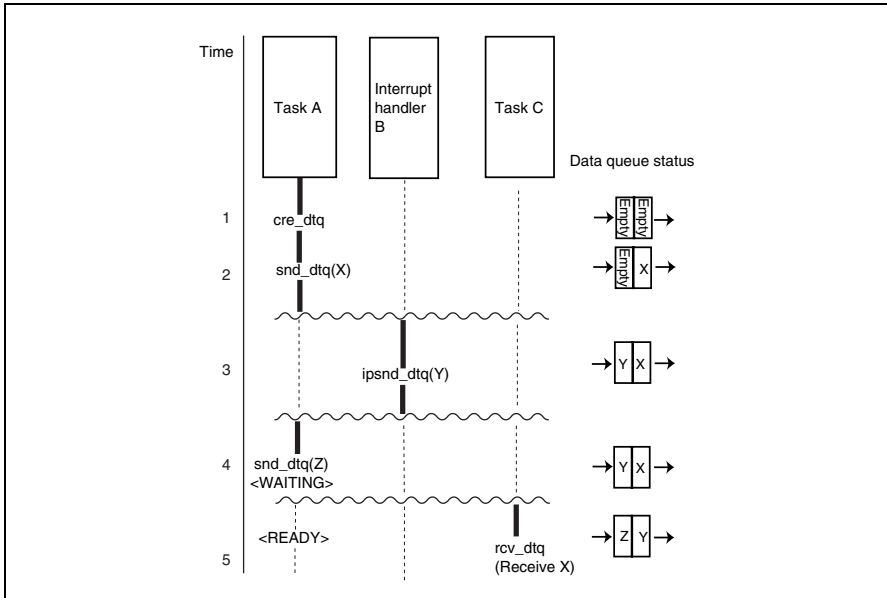

Figure 2.7 Example of Using Data Queue

Description:

Bold lines represent executed processing. The following describes the data queue operation with respect to time.

1. Task A issues `cre_dtq` to create a data queue with a size of two words.
2. Task A sends data X by issuing `snd_dtq`. Data X is copied to the data queue and task A continues execution.
3. Interrupt handler B sends data Y by issuing `ipsnd_dtq`.
4. Task A attempts to send data Z. At this time, since there is no empty entry in the data queue, task A enters the WAITING state.
5. Task C receives data from a data queue by issuing `rcv_dtq`. Task C gets data X, which is initially copied. At this time, since one entry in the data queue is released, data Z, which task A has attempted to send, is copied to a data queue, and task A is released from the WAITING state.

2.11 Mailbox

A mailbox is used to send or receive message data between tasks. Since the communication using a mailbox sends and receives the message start address, it is fast regardless of the message size.

The mailboxes are controlled by the service calls listed in table 2.11.

Table 2.11 Service Calls for Mailbox Control

Service Call Name	Function
cre_mbx, icre_mbx	Creates a mailbox
acre_mbx, iacre_mbx	Creates a mailbox (automatically assigns ID)
del_mbx	Deletes a mailbox
snd_mbx, isnd_mbx	Sends a message to a mailbox
rcv_mbx	Receives a message from a mailbox
prcv_mbx, iprcv_mbx	Receives a message from a mailbox (polling)
trcv_mbx	Receives a message from a mailbox (with timeout)
ref_mbx, iref_mbx	Refers to the mailbox status

Figure 2.8 shows an example of using mailbox.

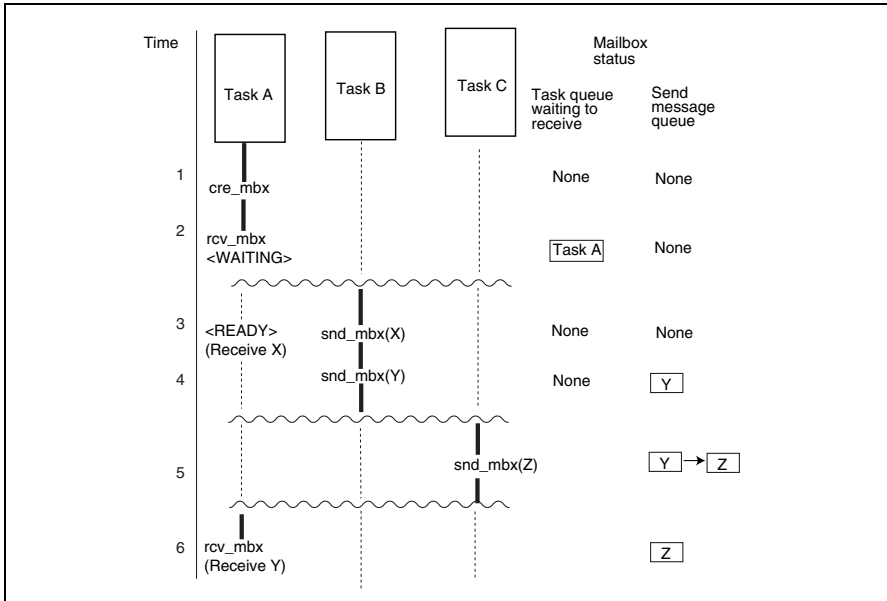

Figure 2.8 Example of Using Mailbox

Description:

Bold lines represent executed processing. The following describes the mailbox operation with respect to time.

1. Task A issues `cre_mbx` to create a mailbox. At this time, the `TA_TFIFO` attribute (tasks waiting to receive are queued in FIFO) and the `TA_MFIFO` attribute (sent messages are queued in FIFO) are specified.
2. Task A attempts to receive a message by using `rcv_mbx`. Since no message is stored in the mailbox, task A enters the `WAITING` state.
3. Task B sends message X to the mailbox using `snd_mbx`, and stores a message in the mailbox.
At this time, task A is released from the `WAITING` state, and task A receives the address of message X.
4. Task B sends message Y to the mailbox using `snd_mbx`.
At this time, since no tasks are waiting for a message, message Y is stored in a message queue.
5. Task C sends message Z to the mailbox using `snd_mbx`. In this case, message Z is also stored in a message queue (FIFO) because the `TA_MFIFO` attribute has been specified.
6. Task A issues `rcv_mbx`. At this time, task A receives the address of message Y, which is placed at the top of the message queue.

2.12 Mutex

A mutex is used to achieve exclusive control by providing a priority ceiling protocol to avoid priority inversion. In this protocol, the task that acquires a mutex is executed at a priority equal to the ceiling priority specified in the mutex.

The mutex is controlled by the service calls listed in table 2.12.

Table 2.12 Service Calls for Mutex Control

Service Call Name	Function
cre_mtx	Creates a mutex
acre_mtx	Creates a mutex (automatically assigns ID)
del_mtx	Deletes a mutex
loc_mtx	Locks a mutex
ploc_mtx	Locks a mutex (polling)
tloc_mtx	Locks a mutex (with timeout)
unl_mtx	Unlocks a mutex
ref_mtx	Refers to the mutex status

Mutexes can also be created by the configurator. Figure 2.9 shows an example of using mutex.

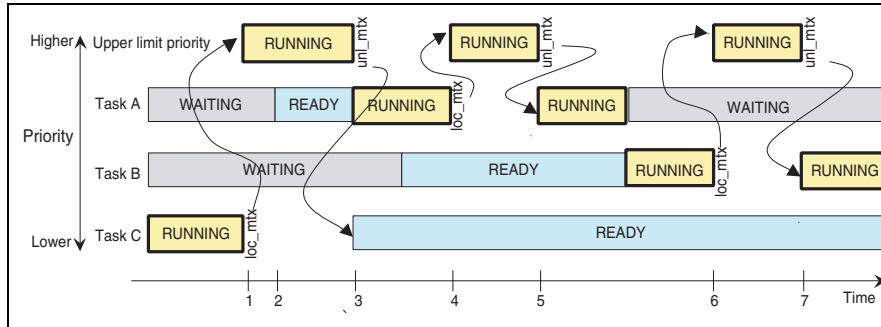

Figure 2.9 Example of Using Mutex

Description:

In figure 2.9, the priorities of tasks A, B, and C are defined as task A highest and task C lowest. Note that the ceiling priority specified by the mutex is specified as higher than the priority of the task that locks the mutex. The following describes the mutex operation with respect to time.

1. Task C locks a mutex by issuing `loc_mtx`. At this time, the priority of task C is pushed up to the ceiling priority specified by the mutex.
2. Task A enters the `READY` state while task C is executed at a priority equal to the ceiling priority specified by the mutex. Although the priority of task A is higher than that of task C at initial specification, task C now locks a mutex to be executed at the ceiling priority which is higher than task A and task A cannot enter the `RUNNING` state. In other words, while task C locks a mutex, task C continues execution even if the initial task priority of task A is higher than task C.
3. Task C unlocks the mutex by issuing `unl_mtx`. At this time, the priority of task C returns to the initial priority and task A enters the `RUNNING` state.
4. Task A issues `loc_mtx` to push its priority up to the ceiling priority specified in the mutex.
5. Task A issues `unl_mtx` to return its priority to the initial priority.
6. Task B issues `loc_mtx` to push its priority up to the ceiling priority specified in the mutex.
7. Task B issues `unl_mtx` to return its priority to the initial priority.

2.13 Message Buffer

A message buffer is used to send and receive data messages between tasks. Since a message itself is copied and transferred in communication using a message buffer, the message area becomes available immediately after the message has been sent regardless of whether a task has received the message or not.

The area of each message buffer is allocated in the message buffer area (CFG_MBFSZ) specified through the configurator.

The message buffers are controlled by the service calls listed in table 2.13.

Table 2.13 Service Calls for Message Buffer Control

Service Call Name	Function
cre_mbf, icre_mbf	Creates a message buffer
acre_mbf, iacre_mbf	Creates a message buffer (automatically assigns ID)
del_mbf	Deletes a message buffer
snd_mbf	Sends a message to a message buffer
psnd_mbf, ipsnd_mbf	Sends a message to a message buffer (polling)
tsnd_mbf	Sends a message to a message buffer (with timeout)
rcv_mbf	Receives a message from a message buffer
prcv_mbf	Receives a message from a message buffer (polling)
trcv_mbf	Receives a message from a message buffer (with timeout)
ref_mbf, iref_mbf	Refers to the message buffer status

Message buffers can also be created by the configurator. Figure 2.10 shows an example of using message buffer.

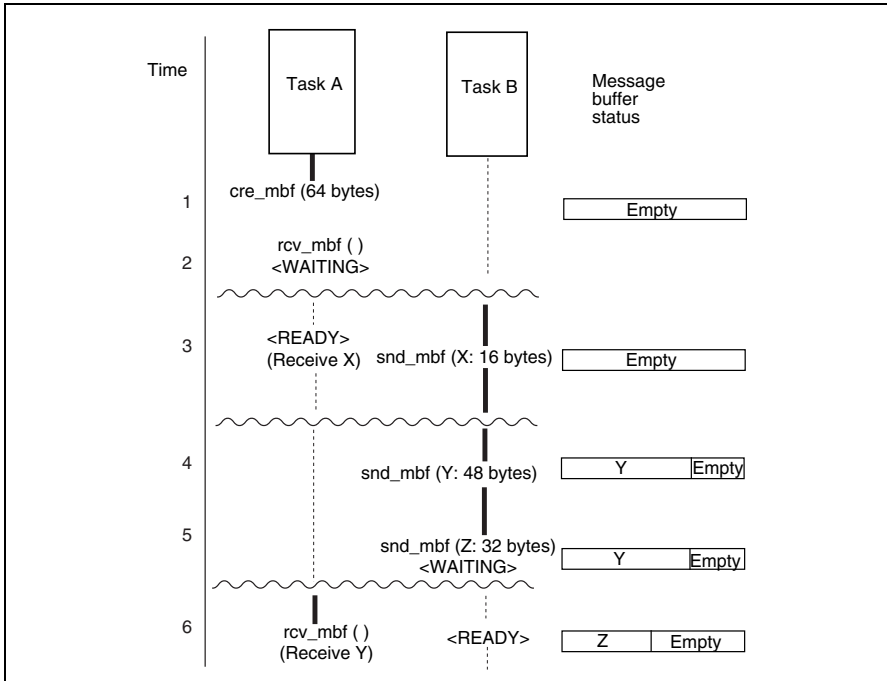

Figure 2.10 Example of Using Message Buffer

Description:

Bold lines represent executed processing. The following describes the message buffer operation with respect to time.

1. Task A creates a 64-byte message buffer, which deals the message where the maximum size is 48 bytes, by issuing `cre_mbf`.
2. Task A receives a message by preparing the 48-byte memory and issuing `rcv_mbf`. Task A is placed in the **WAITING** state since there are no messages in the message buffer.
3. Task B sends a 16-byte message X by issuing `snd_mbf`. At this time, task A is released from the **WAITING** state and message X is copied to the memory prepared by task A. Task A receives message size 16 as the return parameter.
4. Task B sends a 48-byte message Y by issuing `snd_mbf`. At this time, since there are no tasks waiting for a message, message Y is copied to the message buffer. In this case, the kernel uses 4-byte message buffer area to copy message Y to the message buffer, however this is not indicated in figure 2.10.

5. Task B attempts to send 32-byte message Z by issuing `snd_mbf`. At this time, since the message buffer is not large enough to store message Z, task B is placed in the WAITING state.
6. Task A prepares the 48-byte memory and issues `rcv_mbf` to receive a message, 48-byte message Y stored in the message buffer is copied to the memory prepared by task A. Task A receives message size 48 as the return parameter. At this time, since the message buffer has sufficient space to store message Z, task B is released from the WAITING state and message Z is copied to the message buffer.

2.14 Fixed-Size Memory Pool

A task can acquire and use a fixed-size memory block, whose fixed-size is determined for each memory pool, from the fixed-size memory pool. The size can be specified when the memory pool is created.

The area of each memory pool is allocated in the fixed-size memory pool area (CFG_MPF SZ) specified through the configurator.

An area allocated by the application can also be used as a fixed-size memory pool. In this case, the address of a memory pool area must be specified at creation.

The user can choose either of the following management methods through the configurator (CFG_MPFMANAGE).

(1) Conventional method (CFG_MPFMANAGE not selected)

The kernel places the kernel management tables adjacent to the memory blocks in the memory pool. This method is compatible with the previous versions (HI7000/4 V.1.0.05 or earlier, HI7700/4 V.1.03 Release 02 or earlier, and HI7750/4 V.1.1.00 or earlier versions).

(2) Extended method (CFG_MPFMANAGE selected)

The kernel places the kernel management tables outside of the memory pool.

In this method, the application must specify the address of the management tables at creation of the fixed-size memory pool.

The application must allocate the area for management tables.

The fixed-size memory pools are controlled by the service calls listed in table 2.14.

Table 2.14 Service Calls for Fixed-Size Memory Pool Control

Service Call Name	Function
cre_mpf, icre_mpf	Creates a fixed-size memory pool
acre_mpf, iacre_mpf	Creates a fixed-size memory pool (automatically assigns ID)
del_mpf	Deletes a fixed-size memory pool
get_mpf	Gets a fixed-size memory block
pget_mpf, ipget_mpf	Gets a fixed-size memory block (polling)
tget_mpf	Gets a fixed-size memory block (with timeout)
rel_mpf, irel_mpf	Returns a fixed-size memory block
ref_mpf, iref_mpf	Refers to the fixed-size memory pool status

A fixed-size memory pool can also be created by the configurator. Figure 2.11 shows an example of using fixed-size memory pool.

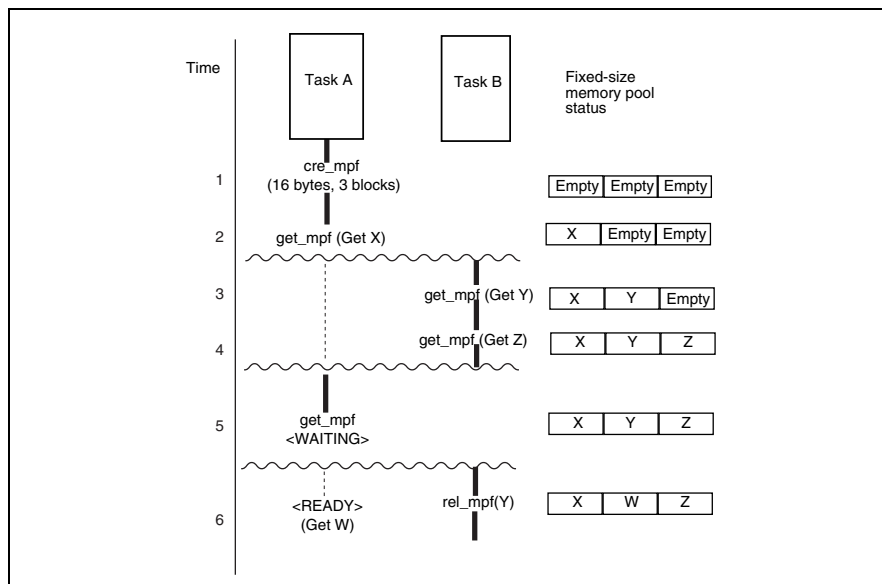

Figure 2.11 Example of Using Fixed-Size Memory Pool

Description:

Bold lines represent executed process. The following describes the fixed-size memory pool operation with respect to time.

1. Task A issues `cre_mpf` to create a fixed-size memory pool that has three 16-byte memory blocks.
2. Task A gets block X by issuing `get_mpf`.
3. Task B gets block Y by issuing `get_mpf`.
4. Task B gets block Z by issuing `get_mpf`.
5. Task A attempts to get a block by issuing `get_mpf`. At this time, no memory blocks are available and task A enters the WAITING state.
6. Task B returns block Y by issuing `rel_mpf`. At this time, task A is released from the WAITING state and the released block Y is allocated to task A.

2.15 Variable-Size Memory Pool

2.15.1 Overview

A task can acquire a variable-size memory block from the variable-size memory pool. Although the variable-size memory pool is more flexible than fixed-size memory pool, the overhead is large when acquiring or releasing variable-size memory block. Also, in a variable-size memory pool, there is a possibility of fragmentation. This means that even if there is enough total space to acquire a variable-size memory block, it cannot be acquired if the area is not contiguous.

The area of each memory pool is allocated in the variable-size memory pool area (CFG_MPLSZ) specified through the configurator.

An area allocated by the application can also be used as a variable-size memory pool. In this case, the address of a memory pool area must be specified at creation.

The user can choose either of the following management methods through the configurator (CFG_NEWMPL).

(1) Conventional method (CFG_NEWMPL not selected)

This method is compatible with the following previous versions

- HI7000/4 V.2.00 Release 02 or earlier
- HI7700/4 V.1.03 Release 02 or earlier
- HI7750/4 V.1.1.00 or earlier

(2) New method (CFG_NEWMPL selected)

This method has the following advantages over the conventional method.

- Acquisition and return of memory blocks are faster when a large number of memory blocks are used in the memory pool.
 - The VTA_UNFRAGMENT attribute can be used to reduce fragmentation of free space.
- When CFG_NEWMPL is selected, note that new members are added to the T_CMPL structure in comparison with the conventional method. For details, refer to section 3.14.1, Create Variable-Size Memory Pool.

The variable-size memory pools are controlled by the service calls listed in table 2.15.

Table 2.15 Service Calls for Variable-Size Memory Pool Control

Service Call Name	Function
cre_mpl, icre_mpl	Creates a variable-size memory pool
acre_mpl, iacre_mpl	Creates a variable-size memory pool (automatically assigns ID)
del_mpl	Deletes a variable-size memory pool
get_mpl	Gets a variable-size memory block
pget_mpl, ipget_mpl	Gets a variable-size memory block (polling)
tget_mpl	Gets a variable-size memory block (with timeout)
rel_mpl, irel_mpl	Returns a variable-size memory block
ref_mpl, iref_mpl	Refers to the variable-size memory pool status

A variable-size memory pool can also be created by the configurator.

Figure 2.12 shows an example of using variable-size memory pool.

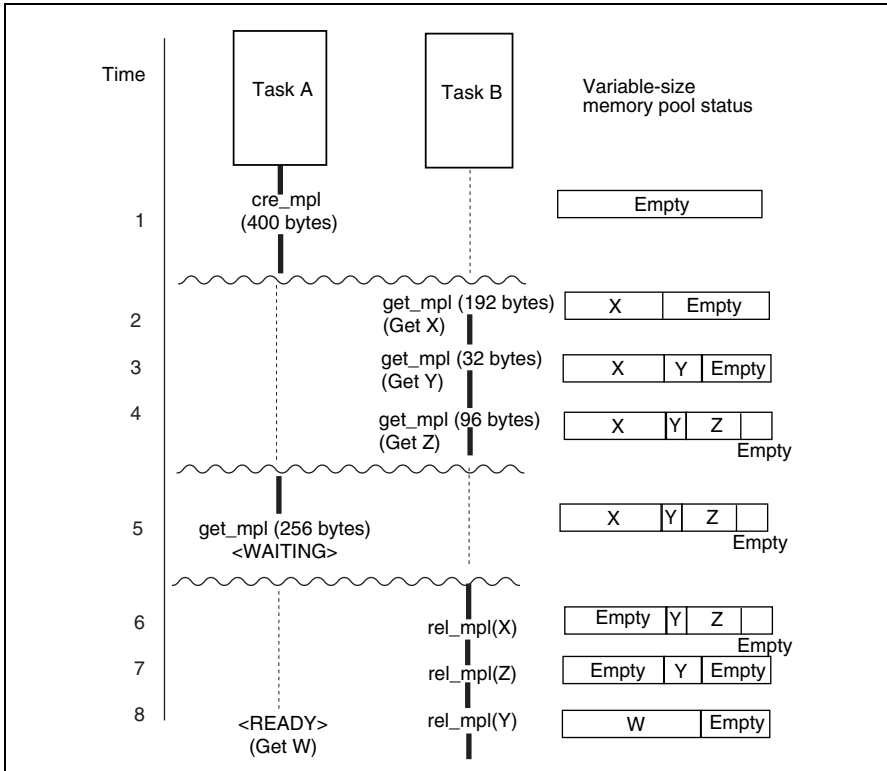

Figure 2.12 Example of Using Variable-Size Memory Pool

Description:

Bold lines represent executed process. The following describes the variable-size memory pool operation with respect to time.

1. Task A creates a 400-byte variable-size memory pool by issuing `cre_mpl`.
2. Task B acquires 192-byte memory block X by issuing `get_mpl`. At this time, the kernel uses 16 bytes in the memory pool. This is not indicated in figure 2.12.
3. Task B also acquires 32-byte memory block Y by issuing `get_mpl`.
4. Task B also acquires 96-byte memory block Z by issuing `get_mpl`.
5. Task A attempts to acquire a 256-byte memory block by issuing `get_mpl`. However, the available memory block is insufficient to assign a 256-byte memory block to task A, so task A enters the `WAITING` state.
6. Task B returns 192-byte memory block X by issuing `rel_mpl`. At this time, since there is not 256 bytes of contiguous memory in the memory pool, task A remains in the `WAITING` state.

7. Task B returns 96-byte memory block Z by issuing `rel_mpl`. At this time, the total available memory blocks is more than 256 bytes, however there is not 256 bytes of contiguous memory in the memory pool, so task A remains the WAITING state.
8. Task B returns 32-byte memory block Y by issuing `rel_mpl`. At this time, since there is more than 256 bytes of contiguous memory in the memory pool, task A is released from the WAITING state and 256-byte memory block W is assigned to task A.

2.15.2 Controlling Fragmentation of Free Space

Repeated acquisition and release of memory blocks in a variable-sized memory pool causes fragmentation of the available memory area. When the memory area is fragmented, even if the total amount of free space is sufficient for a required memory block, the non-contiguity of the available areas means that a large memory block cannot be acquired (figure 2.13).

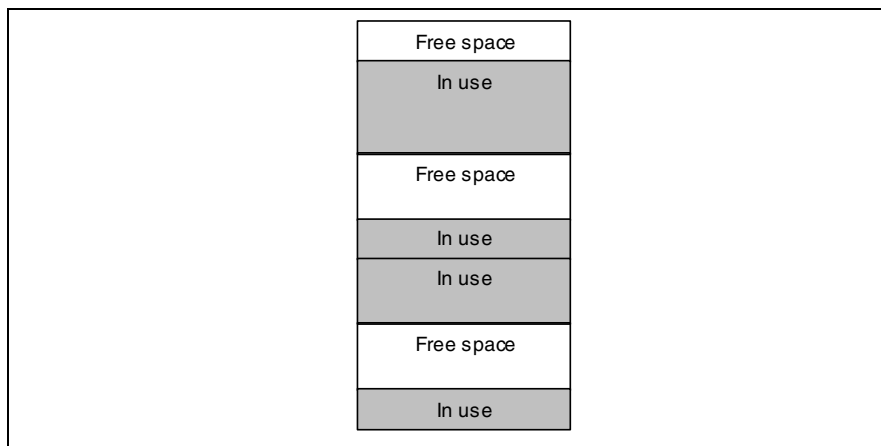

Figure 2.13 Fragmentation of Free Space

Selecting `CFG_NEWMPL` on the [Variable-Size Memory Pool] page of the configurator slightly reduces the degree of fragmentation. Specify the `VTA_UNFRAGMENT` attribute for variable-size memory pools to further reduce fragmentation. Although specification of the `VTA_UNFRAGMENT` attribute generally helps in reducing fragmentation, the degree of fragmentation will depend on how variable-size memory pools are used.

When `CFG_NEWMPL` is selected, parameters (minimum block size, number of sectors, and management table address) for the `VTA_UNFRAGMENT` attribute are added to the `T_CMPL` structure, which is specified at the time of variable-size memory pool creation.

When the `VTA_UNFRAGMENT` attribute is specified, the sector management method is applied to the variable-size memory pools. This method reduces fragmentation when a large number of small blocks and some large blocks are allocated in a large memory pool.

In this method, up to (minimum block size \times 8 bytes) is handled as a "small block" size. The size of each block acquisition request is rounded up as shown in table 2.16.

When a "small block" is requested, the kernel allocates a sector consisting of blocks each of which has the rounded request size. The sector size is always $\text{minblksz} \times 32$. This means that the number of blocks in a sector depends on the requested size.

Table 2.16 Small Block Control

Acquisition Request Size (blksz)*	Size after Rounding *	Number of Blocks in a Sector
$0 < \text{blksz} \leq \text{minblksz}$	minblksz	32
$\text{minblksz} < \text{blksz} \leq \text{minblksz} \times 2$	$\text{minblksz} \times 2$	16
$\text{minblksz} \times 2 < \text{blksz} \leq \text{minblksz} \times 4$	$\text{minblksz} \times 4$	8
$\text{minblksz} \times 4 < \text{blksz} \leq \text{minblksz} \times 8$	$\text{minblksz} \times 8$	4

Note: blksz: Requested size
minblksz: Minimum block size

Then the kernel assigns one of the memory blocks in the sector as the requested block. The remaining blocks in the sector are reserved for later requests for memory blocks with this size or a smaller size.

In this manner, small blocks are allocated contiguously so that a larger free space is left available.

Figure 2.14 shows an example of a variable-size memory pool when the minimum block size is 32.

First a 32-byte memory block is requested. Sector [A] with $32 \times 32 = 1024$ bytes is allocated and 32-byte area [A-1] in the sector is assigned for the requested block (figure 2.14 (1)). When a 16-byte memory block is then requested, 32-byte area [A-2] in sector A is assigned (figure 2.14 (2)).

Next, a 36-byte memory block is requested. Since the size of each block in sector A is 32 bytes, no block in sector A can be assigned for this request. To respond to this request, new sector [B] is allocated for 16 blocks \times 64 bytes (the requested size, 36, is rounded up to a multiple of the minimum block size) = 1024 bytes, and 64-byte area [B-1] is assigned for the requested block (figure 2.14 (3)).

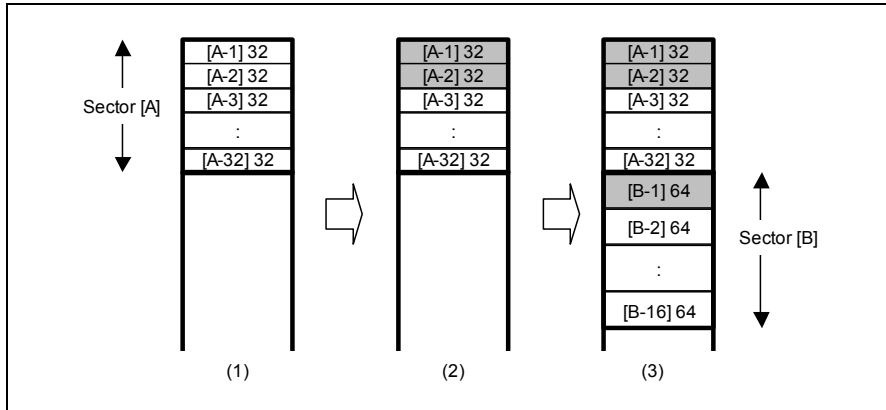

Figure 2.14 Example of Variable-Size Memory Pool

If the maximum number of sectors have already been used or contiguous free space is not sufficient to create a new sector, the requested size of the memory block is allocated without creating a sector. In this case, free space may be fragmented. If contiguous free space is not sufficient for the requested size, the memory block is allocated in a sector for a larger block size.

When all blocks in a sector are released, the sector itself is also released.

When a large block is requested (larger than $\text{minblksize} \times 8$), the kernel always allocates a block for the requested size without creating a sector.

2.15.3 Management of Variable-Size Memory Pool

The kernel creates a management table in a variable-size memory pool to manage the allocated memory blocks. When determining the variable-size memory pool, note that the variable-size memory pool area is used for the kernel management table area as well as the memory block area to be acquired by the application.

(1) When CFG_NEWMPL is not selected

The kernel creates a 16-byte management table when a memory block is acquired. This management table is released when the memory block is returned.

(2) When CFG_NEWMPL is selected

When the VTA_UNFRAGMENT attribute is specified, the kernel creates a 32-byte management table at creation of a sector. This management table is released when the sector is released.

The kernel also creates a 32-byte management table when a memory block is allocated outside of a sector while the VTA_UNFRAGMENT attribute is specified or when a memory block is allocated while the VTA_UNFRAGMENT attribute is not specified. This management table is released when the memory block is returned.

2.16 Time Management

The kernel provides the following functions related to time management:

- Reference to and setting of system clock
- Time event handler (cyclic handler, alarm handler, and overrun handler) execution control
- Task execution control such as timeout and time slicing

The kernel uses a counter called the system clock to perform the above functions. The unit of time used in the service calls is 1 ms. A time tick can be specified as a value other than 1 ms by specifying CFG_TICNUME (numerator of time tick cycle) and CFG_TICDENO (denominator of time tick cycle) by the configurator.

To use the time management function, it is necessary to incorporate a timer driver. There are two kinds of timer drivers, a standard timer driver and an optimization timer driver. However, an optimization timer driver is the function currently supported only by HI7700/4. For details, refer to Appendix D, Timer Driver.

The system clock is controlled by the service calls listed in table 2.17. Note that `isig_tim` is automatically executed according to the configurator specifications (CFG_TIMUSE).

Table 2.17 Service Calls for System Clock Control

Service Call Name	Function
<code>isig_tim</code>	Provides a time tick
<code>set_tim, iset_tim</code>	Sets system clock
<code>get_tim, iget_tim</code>	Refers to system clock

2.16.1 Cyclic Handler

The cyclic handler is a time event handler that can be initiated at a specific cycle time interval after the initiation phase has been passed.

Cyclic handlers are controlled by the service calls listed in table 2.18.

Table 2.18 Service Calls for Cyclic Handler Control

Service Call Name	Function
cre_cyc, icre_cyc	Creates a cyclic handler
acre_cyc, iacre_cyc	Creates a cyclic handler (automatically assigns ID)
del_cyc	Deletes a cyclic handler
sta_cyc, ista_cyc	Initiates a cyclic handler
stp_cyc, istp_cyc	Stops a cyclic handler
ref_cyc, iref_cyc	Refers to a cyclic handler status

The cyclic handler can also be created by the configurator. There are two methods to initiate the cyclic handler; storing the initiation phase, and not storing the initiation phase. In storing the initiation phase, the cyclic handler is initiated based on the timing when the cyclic handler is created. In not storing the initiation phase, the cyclic handler is initiated based on the timing when the cyclic handler is started.

Figure 2.15 shows an example of using cyclic handler.

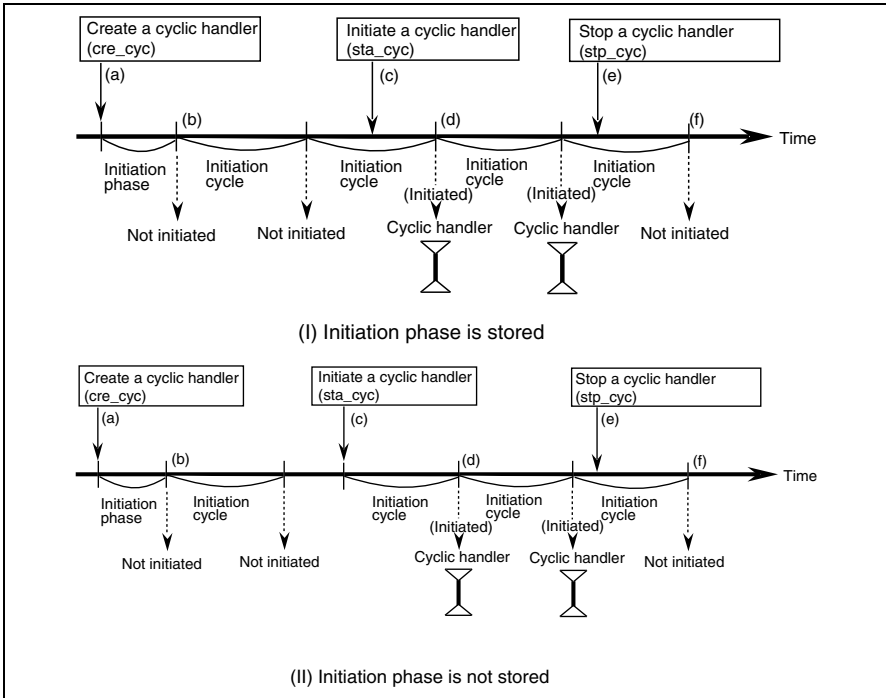

Figure 2.15 Example of Using Cyclic Handler

Description:

- (a) A cyclic handler (without TA_STA attribute specification) is created.
- (b) The cyclic handler is not initiated after cycle time has passed since the cyclic handler operation has not been initiated. The cyclic handler operation is initiated by issuing `sta_cyc`.
- (c) When the initiation phase is stored as shown in (I) in figure 2.15, the cyclic handler is initiated based on the initiation cycle after the cyclic handler has been created. When the initiation phase is not stored as shown in (II) in Figure 2.15, the cyclic handler is initiated based on the initiation cycle after the `sta_cyc` service call has been issued.
- (d) The cyclic handler is terminated by issuing the `stp_cyc` service call.
- (e) The cyclic handler is not initiated after cycle time has passed since the cyclic handler operation has been terminated.

2.16.2 Alarm Handler

The alarm handler is a time event handler that can be initiated once when the specified time has been reached. By using the alarm handler, processes can be done according to time.

Alarm handlers are controlled by the service calls listed in table 2.19.

Table 2.19 Service Calls for Alarm Handler Control

Service Call Name	Function
cre_alm, icre_alm	Creates an alarm handler
acre_alm, iacre_alm	Creates an alarm handler (automatically assigns ID)
del_alm	Deletes an alarm handler
sta_alm, ista_alm	Initiates an alarm handler
stp_alm, istp_alm	Stops an alarm handler
ref_alm, iref_alm	Refers to an alarm handler status

The alarm handler can also be created by the configurator. Figure 2.16 shows an example of using alarm handler.

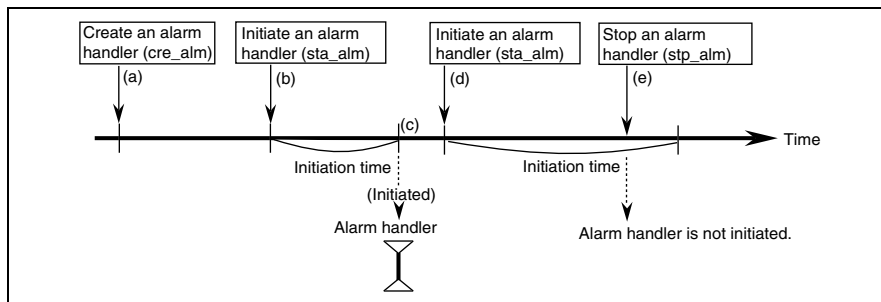

Figure 2.16 Example of Using Alarm Handler

Description:

- (a) An alarm handler is created.
- (b) The alarm handler operation is initiated by issuing sta_alm.
- (c) The alarm handler is initiated after the specified initiation time has passed.
- (d) If sta_alm is issued by specifying another initiation time, the alarm handler starts execution again.
- (e) Since stp_alm is issued before the initiation time has passed, the alarm handler is not initiated.

2.16.3 Overrun Handler

The overrun handler is a time event handler that is initiated when the specified time has been exceeded. Only one overrun handler can be defined in a single system.

The overrun handler is controlled by the service calls listed in table 2.20.

Table 2.20 Service Calls for Overrun Handler Control

Service Call Name	Function
def_ovr	Defines an overrun handler
sta_ovr, ista_ovr	Initiates an overrun handler
stp_ovr, istp_ovr	Stops an overrun handler
ref_ovr, iref_ovr	Refers to an overrun handler status

The overrun handler can also be created by the configurator. Figure 2.17 shows an example of using overrun handler.

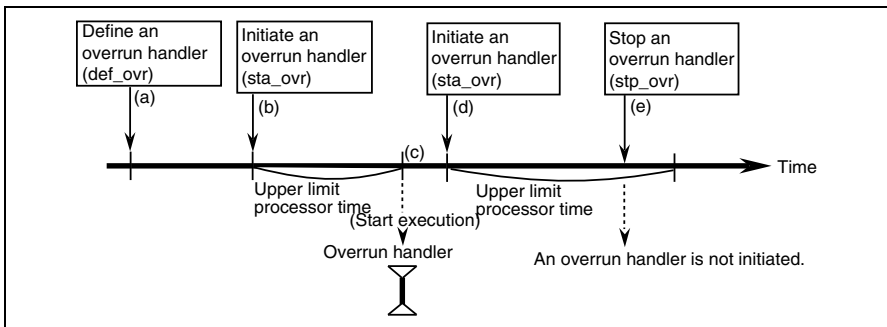

Figure 2.17 Example of Using Overrun Handler

Description:

- An overrun handler is defined.
- The upper-limit processor time for the task is specified by the `sta_ovr` service call. The overrun handler is initiated at this point.
- If a total processor time used by the task exceeds the upper-limit processor time, the overrun handler is initiated.
- If the upper-limit processor time is modified by the `sta_ovr` service call, the overrun handler is initiated again.
- If `stp_ovr` is issued before the total processor time has exceeded the upper-limit processor time, the overrun handler is terminated. In this case, the overrun handler is not initiated even if the upper-limit processor time has been exceeded.

2.16.4 Notes on Time Management

(1) Drawbacks due to the repeated use

The following is performed when a timer interrupt occurs:

- a. System clock is updated.
- b. All alarm handlers that reached the initiation time are initiated and executed.
- c. All cyclic handlers that reached the cycle time are initiated and executed.
- d. The overrun handler is initiated and executed when the total processor time used by the task has reached the specified upper limit processor time.
- e. Timeout processing is performed after service calls such as `tslp_tsk` with timeout function, have been issued and the specified timeout time has elapsed.

The processes from a to e are performed with the timer interrupt level masked. Among these processes, b, c, and e may overlap for multiple tasks and handlers. In that case, the processing time of the kernel becomes very long and results in the following defects.

- Delay of the response to interrupts
- Delay of system clocks

To avoid these problems, the following steps must be taken:

- The time event handler processing time must be as short as possible.
- The time event handler cycle and the timeout value specified by the timeout service call must be set to as large a value as possible. If the cycle time of a cyclic handler is 1 ms and the handler's processing time takes longer than 1 ms, that cyclic handler will be executed forever; and the system will hang.

(2) Time Watch Method

Time parameters specified in service calls are specified using relative time. For example, if the relative time is specified as 1 ms, the corresponding event processing is initiated at the time tick when 1 ms has elapsed since the service call was issued. If the relative time is specified as 0 ms, the corresponding event processing is initiated at the first time tick after the service call is issued.

The system clock can be changed by issuing the `set_tim` service call. Note, however, that the system clock for an event to which a time management request is issued before the `set_tim` service call is not affected.

2.17 System State Management

The service calls listed in table 2.21 can be used to control system state.

Table 2.21 Service Calls for System State Management

Service Call Name	Function
rot_rdq, irot_rdq	Rotates ready queue
get_tid, iget_tid	Refers to the task ID
loc_cpu, iloc_cpu	Enters CPU-locked state
unl_cpu, iunl_cpu	Releases CPU-locked state
dis_dsp	Disables dispatch
ena_dsp	Enables dispatch
sns_ctx	Refers to the context
sns_loc	Refers to the CPU-locked state
sns_dsp	Refers to the dispatch-disable state
sns_dpn	Refers to the dispatch-enable state
vsta_knl, ivsta_knl	Initiates the kernel
vsys_dwn, ivsys_dwn	System down
vget_trc, ivget_trc	Acquires user event trace information
ivbgn_int	Acquires trace information on interrupt handler initiation
ivend_int	Acquires trace information on interrupt handler termination

2.17.1 System Down

When an error occurs, control is passed to the system down routine. Errors can be classified into the following three types:

1. When the service call vsys_dwn or ivsys_dwn was issued from application.
2. When an error was detected inside the kernel.
3. When an undefined interrupt or exception occurred.

The user must create the system down routine. For details, refer to section 4.12, System Down Routines.

2.17.2 Service Call Trace Function

The service call trace function is used to acquire the history of the service calls that are issued. The debugging extension is used to visually refer to the acquired data.

The service call trace function automatically acquires task ID, PC, and service call parameters in the following timing.

- A service call is issued and returned
- A task is initiated and terminated
- A task exception processing routine is initiated and terminated

If the `ivbgn_int` and `ivend_int` service calls are described at the beginning and end of the interrupt handler, the trace information on interrupt handler initiation and termination can also be acquired. In addition, the `vget_trc` and `ivget_trc` service calls allow the user to acquire trace information on all timing.

Trace Information Storage Area: Trace information can be stored either in the target memory of debugger such as E6000 emulator or simulator. The former is called "target trace" and the latter is called "emulator trace" or "tool trace". Although the environment where emulator trace can be used is limited, there is the feature of hardly needing the domain for service call trace on a target memory. Refer to the manual or online help of the debugging extension for the environment where emulator trace (tool trace) can be used.

Preparation for Service Call Trace Function: The service call trace function is specified in the debugging function page of the configurator. At linkage, sections for trace such as `B_hitrcbuf` for target trace and `B_hitrceml` for emulator trace must be assigned to the appropriate addresses.

Note on Service Call Trace Function: The following must be noted when using the service call trace function:

a. Degradation of performance

When the service call trace function is used, the performance of the kernel is degraded a little.

b. Service call information not traced

Service calls for non-task context such as `ixxx_yyy` are all acquired as service calls for task context such as `xxx_yyy`.

Following service calls cannot be traced.

- `isig_tim`
- `cal_svc`, `ical_svc`
- `vsta_knl`, `ivsta_knl`
- `vsys_dwn`, `ivsys_dwn`
- `vini_cac`, `ivini_cac`

While using HI7700/4, the following service call also cannot be traced.

- `vchg_cop`

While using HI7750/4, the following service calls also cannot be traced.

- `vfls_cac`, `ivfls_cac`
- `vclr_cac`, `ivclr_cac`
- `vinv_cac`, `ivinv_cac`

2.18 Interrupt Management and System Configuration Management

In this kernel, interrupts and exceptions are classified as follows:

- Reset: CPU reset. A program executed at CPU reset is called the CPU initialization routine.
- Interrupt: An interrupt is generated from external interrupt pins and peripheral modules.
- CPU exception: A CPU exception is an exception such as an address error or divide-by-zero. A CPU exception also includes a trap generated by a TRAPA instruction. When a CPU exception occurs, a CPU exception handler is executed.

Interrupts and exceptions are controlled by the service calls listed in tables 2.22 and 2.23.

Table 2.22 Service Calls for Interrupt Control

Service Call Name	Function
def_inh, ideo_inh	Defines an interrupt handler
chg_ims, ichg_ims	Changes interrupt mask
get_ims, igo_ims	Refers to interrupt mask

Table 2.23 Service Calls for Exception Control

Service Call Name	Function
def_exc, ideo_exc	Defines a CPU exception handler
vdef_trp, ivdef_trp	Defines a CPU exception handler (for TRAPA instruction)
ref_cfg, iref_cfg	Refers to the configuration information
ref_ver, iref_ver	Refers to version information

Interrupt handlers and CPU exception handlers (including the CPU exception handler for the TRAPA instruction) can also be defined by the configurator. When an undefined interrupt or exception occurs, the system down routine will be initiated.

2.18.1 Resetting the CPU and Initiating the Kernel

To reset the CPU and initiate the kernel, refer to figure 2.18.

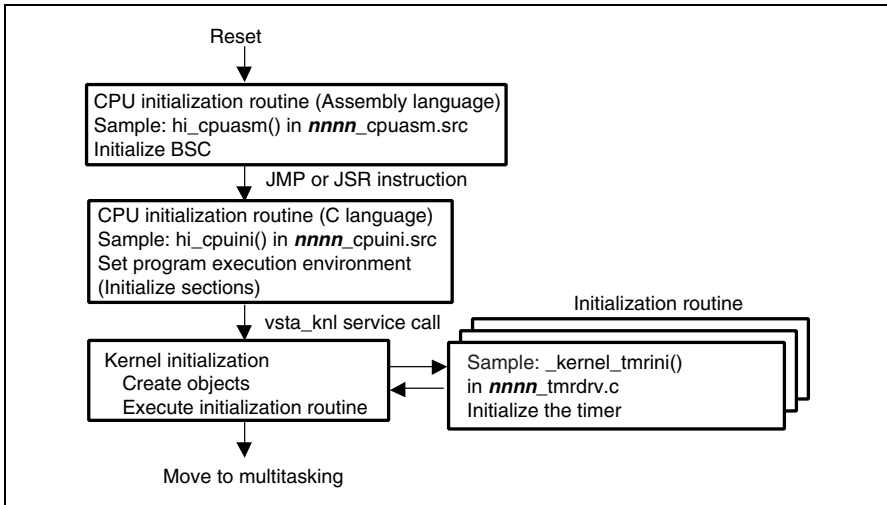

Figure 2.18 Flowchart from CPU Reset to Kernel Initiation

The CPU initialization routine should set the bus state controller (BSC) so that programs can correctly access memory. A C-language program accesses stacks; therefore, the stacks must be ready to be accessed before the C-language program is executed. The CPU initialization routine should also set the C program execution environment, such as initializing sections. For details, refer to the SuperH™ RISC engine C/C++ Compiler User's Manual.

Then, `vsta_knl` or `ivsta_knl` is called to initiate the kernel. When the kernel is initiated, control does not return to the caller of `vsta_knl` and `ivsta_knl`.

The following is performed by `vsta_knl` and `ivsta_knl`:

- All interrupts are disabled (SR.IMASK = 15 in the HI7000/4 or SR.BL = 1 in the HI7700/4 and HI7750/4).
- The VBR is initialized.
- SR.BL is cleared to 0 and SR.IMASK is set to 15 in the HI7700/4 and HI7750/4.
- The kernel work area is initialized.
- SR.IMASK is set to the kernel interrupt mask level. In the HI7700/4 and HI7750/4, SR.BL is cleared at this time.
- The initial defined objects specified in the configurator are created.

- g. The system initialization routine specified in the configurator is called.
- h. The multitasking environment is entered. All initial tasks are executed.

The program which issues the `vsta_knl` or `ivsta_knl` service call must normally be linked with the kernel. Note, however, that since the address of `vsta_knl` and `ivsta_knl` service call is equal to the start address of `P_hireset` section, `vsta_knl` can be issued only by specifying the `P_hireset` section start address without kernel linkage.

For details on creating a CPU initialization routine, refer to section 4.11, CPU Initialization Routines.

2.18.2 Interrupt Handlers

(1) Overview

When an interrupt occurs, an interrupt handler is initiated via kernel interrupt service routine. To improve the interrupt response time, the kernel can define the interrupt mask level at system configuration. The interrupt mask level is called the kernel interrupt mask level (`CFG_KNLMSKLVL`). Interrupt handlers with mask levels higher than the kernel interrupt mask level can be immediately accepted even when the kernel is executed. Note, however, that the service call must be issued by the interrupt handlers with the levels higher than the kernel interrupt mask level.

An interrupt handler is executed in the non-task context state. Tasks are scheduled after the interrupt handler has completed execution; tasks are not scheduled even when a task with high priority is in the `READY` state due to the service call issued while the interrupt handler was being executed.

The interrupt handler must not make the interrupt mask level (`IMASK` bits in the `SR` register) lower than the interrupt level.

(2) Direct interrupt handlers (only in the HI7000/4)

The HI7000/4 provides direct interrupt handlers, i.e. handlers that do not require a kernel interrupt service routine. A direct interrupt handler is directly recorded as a CPU interrupt vector, and the response is better than a normal interrupt handler. Direct interrupt handlers must have interrupt levels higher than the kernel interrupt mask level.

The difference between normal and direct interrupt handlers is shown in table 2.24.

Table 2.24 Normal Interrupt Handler and Direct Interrupt Handler

Item	Normal Interrupt Handler	Direct Interrupt Handler
Initiation method when an interrupt occurs	Initiated via kernel interrupt processing	Initiated without kernel intervention (a direct interrupt handler is defined by a CPU interrupt vector)
Service call issuing method	Service calls for non-task context are used. Note, however, that an interrupt handler with level higher than CFG_KNLMSKLVL must not issue a service call.	
Interrupt level	An interrupt with level higher than CFG_KNLMSKLVL must be defined as a direct interrupt handler.	
Definition method	def_inh or idef_inh service call Defined by the configurator	

(3) Register banks (SH-2A, SH2A-FPU)

Refer to section 4.2.9, Register Banks (SH-2A, SH2A-FPU).

2.18.3 Disabling Interrupts

Interrupts are prohibited in one of the following four ways.

- (a) `loc_cpu`, `iloc_cpu` service calls: Change the IMASK bits in the SR register to the kernel interrupt mask level.
- (b) `chg_ims`, `ichg_ims` service calls: Change IMASK bits in the SR register.
- (c) Change IMASK bits in the SR register without a service call
- (d) Change BL bit in the SR register without a service call (SH-3, SH3-DSP, SH4AL-DSP, SH-4, SH-4A)

Do not issue service calls when the level set by the IMASK bits in the SR register is higher than the kernel interrupt mask level (CFG_KNLMSKLVL) and the BL bit in the SR register is 1.

(a) `loc_cpu`, `iloc_cpu` service calls

These calls lock the CPU. When CPU is locked, interrupts with levels below the kernel interrupt mask level are masked. During this period, the service calls that can be issued are restricted to those described in 3.2.5, System State and Service Calls.

To cancel the CPU-locked state, issue `unl_cpu` or `iunl_cpu`. If an interrupt handler, CPU exception handler, or time-event handler locks the CPU, the state must be released within the same handler.

(b) `chg_ims`, `ichg_ims` service calls

The IMASK bits in the SR register are changed to the specified value. That is, interrupts below the specified level are masked. When the CPU is locked, a `chg_ims` or `ichg_ims` call leads to an error with the code `E_CTX`.

The context state is handled as a non-task context while the IMASK bits are changed to a value other than 0 by `chg_ims` or `ichg_ims`.

To cancel the masking of interrupts by these calls, call `ichg_ims` to restore the IMASK bits in the SR register to the value they had before the change.

However, when `chg_ims` has been called to mask interrupts by setting a value [A] for the IMASK bits in the task context, the IMASK bits in the SR register must be [A] for `ichg_ims` to be called to restore the IMASK bits. Otherwise, correct operation is not guaranteed. The following is a bad example:

```
/* At this point,      - Task context
                       - SR.I = 0      */
chg_ims(SR_IMS05); /* (1) Change SR.I to 5 */
set_imask(8);     /* (2) Change SR.I to 8 */
ichg_ims(SR_IMS00); /* (3) Change SR.I to 0 */
                  /* The IMASK bits are 8; it must be 5 */
                  /* for this call to work. */
```

To improve this example, add processing which returns IMASK bits to 5 before (3).

```
/* At this point,      - Task context
                       - SR.I = 0      */
chg_ims(SR_IMS05); /* (1) Change SR.I to 5 */
set_imask(8);     /* (2) Change SR.I to 8 */
set_imask(5);     /* (Add) Change SR.I to 5 */
ichg_ims(SR_IMS00); /* (3) Change SR.I to 0 */
```

(c) Change IMASK bits of the SR register without a service call

The IMASK bits in the SR register are changed by the LDC instruction. In the C language, the intrinsic functions `set_imask()` or `set_cr()`, which are supported by the compiler, are used for this purpose.

In the task context, the IMASK bits can only be changed to values greater than the kernel interrupt mask level by this method. If the value of the IMASK bits is changed to some other value, correct operation is not guaranteed. This restriction does not apply in non-task contexts.

To cancel the change to the interrupt mask, restore the IMASK bits to their values before the change.

(d) Change BL bit of the SR register without a service call (SH-3, SH3-DSP, SH4AL-DSP, SH-4, SH-4A)

The BL bit in the SR register is changed to 1 by the LDC instruction. In the C language, the intrinsic function `set_cr()`, which is supported by the compiler, is used for this purpose.

To cancel the interrupt mask, restore the pre-change value of the BL bit in the SR register.

2.18.4 Kernel Interrupt Mask Level (CFG_KNLMSKLVL):

The kernel interrupt mask level (CFG_KNLMSKLVL) specifies the interrupt level to mask interrupts during kernel execution. The kernel interrupt mask level can be specified by the configurator. However, interrupts having an interrupt level higher than the kernel interrupt mask level are immediately accepted even during kernel execution. Note that handlers for the interrupts having an interrupt level higher than the kernel interrupt mask level are not allowed to issue a service call. When the interrupt mask level is set higher than the kernel interrupt mask level, service calls cannot be issued, except when modifying the level of the interrupt mask equal to or lower than the kernel interrupt mask level by using `chg_ims`.

In the HI7000/4, interrupt handlers with interrupt levels higher than the kernel interrupt mask level must be defined as direct interrupt handlers.

2.18.5 CPU Exception

The CPU exception handler (including the TRAPA instruction) operates using the same context as that when an exception occurred. The CPU exception handler uses the same stack as that used by the exception source. Since the priority of the CPU exception handler is higher than that of the dispatcher, task switching cannot be performed during the CPU exception processing.

In CPU exception handler processing, system states such as task execution mode remain at the same state as when the exception occurred.

The CPU exception handler operates using the context at the time of the exception occurrence. Note that the CPU exception handler can call only the following service calls:

- sns_ctx
- sns_loc
- sns_dsp
- sns_dpn
- sns_tex
- get_tid, iget_tid
- ras_tex, iras_tex
- vsta_knl, ivsta_knl
- vsys_dwn, ivsys_dwn

2.19 Service Call Management

A service call processing routine can be created and defined in the kernel as an extended service call routine. If a process common to the system is created as an extended service call routine, the handler can be called without linking to the processing routine.

Extended service calls are controlled by the service calls listed in table 2.25.

Table 2.25 Service Calls for Extended Service Call Control

Service Call Name	Function
def_svc, ndef_svc	Defines an extended service call
cal_svc, ical_svc	Issues an extended service call

Figure 2.19 shows an example of an extended service call routine.

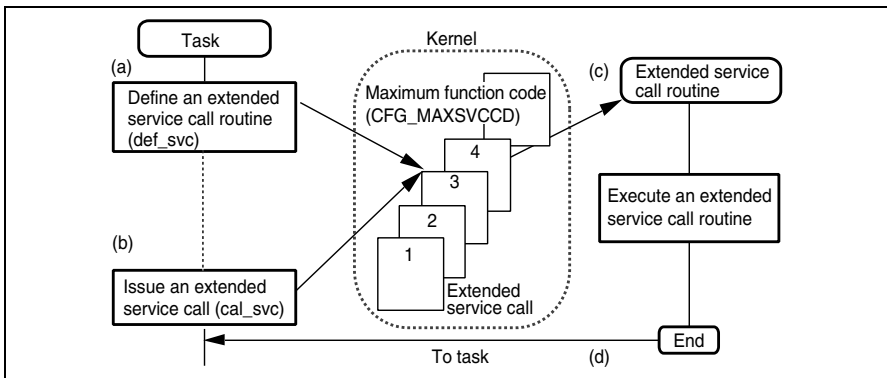

Figure 2.19 Example of Extended SVC Handler

Description:

- Defines an extended service call.
- Issues the service call `cal_svc` to call the defined extended service call routine.
- Initiates the extended service call routine by the service call `cal_svc` issued by a task.
- Returns the extended service call routine to the caller.

In an extended service call routine, the task execution mode of the task which calls the extended service call routine is retained. If the task calling the extended service call routine does not mask the task termination request (ter_tsk) or suspension request (sus_tsk), these requests can also be accepted immediately in the extended service call routine.

2.20 Cache Support (only for HI7700/4 and HI7750/4)

This function is used when it is necessary to establish coherence between the memory and cache, such as when transferring the memory contents of an application to the cache (DMA transfer).

The cache support is controlled by service calls listed in table 2.26.

Table 2.26 Service Calls for Cache Support Control

Service Call Name	Function
vini_cac, ivini_cac	Initializes cache
vclr_cac, ivclr_cac	Clears the cache
vfls_cac, ivfls_cac	Flushes the cache
vinv_cac, ivinv_cac	Invalidates the cache

Figure 2.20 shows an example of using a cache support.

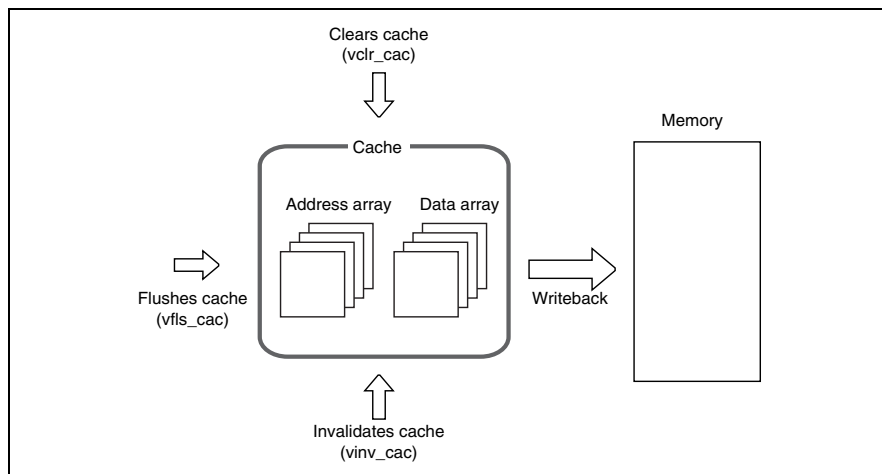

Figure 2.20 Example of Using a Cache Support

Flushing the Cache: By writing the contents of the cache to the memory, coherence of the cache and the memory is established. When a bus master such as the DMA reads memory updated by the CPU, the contents of the cache must be flushed. Note that when the cache is used in the write-through mode, data does not have to be flushed.

Clearing the Cache: The service call `vclr_cac` writes the contents of cache to the memory and invalidates the contents of the cache

Invalidating the Cache: When the CPU reads memory updated by a bus master such as the DMA, the contents of cache must be invalidated so that without fail the contents of the memory can be read by the CPU. If the contents of the cache are invalidated for write-back mode, they will not be written back to the memory even if data, not written back to the memory exists in the cache. Therefore, the cache contents must be written back to the memory before invalidating the cache.

The cache support function is used when it is necessary to establish coherence of the memory and the cache, such as when transferring the memory contents of an application (DMA transfer).

Initializing the Cache: Before using the cache support function, `vini_cac` or `ivini_cac` must be executed. `vini_cac` and `ivini_cac` can be called before kernel initiation.

2.21 Kernel Idling

When there is no executable task, the kernel enters the endless loop after handling the pre-fetch function described later, and waits for an interrupt.

To use the low-power consumption mode of the CPU, the lowest-priority task is normally used for transition to that mode.

2.22 Pre-fetch Function (only for HI7700/4 and HI7750/4)

The pre-fetch function allows an interrupt that occurs after the idle state to response quickly. When the kernel enters the idle state, the pre-fetch function executes the PREF instruction (cache pre-fetch instruction).

The area pre-fetched by the PREF instruction is specified by the configurator. Since the PREF instruction supported by the SH-3 and SH3-DSP uses the instruction/data mixed-cache, either program area or data area can be specified by the configurator. Since the PREF instruction supported by the SH4AL-DSP, SH-4, and SH-4A uses operand cache, only data area can be specified by the configurator.

2.23 Optimized Timer Driver (only for HI7700/4)

The HI7700/4 supports the optimized timer driver function whose purpose is low-power consumption. For details, refer to Appendix E, Optimized Timer Driver (HI7700/4).

2.24 DSP Standby Control Function (only for HI7700/4)

The HI7700/4 supports the DSP standby control function whose purpose is low-power consumption. For details, refer to Appendix F, DSP Standby Control.

Section 3 Service Calls

3.1 Overview

Service calls are classified as shown in table 3.1.

Table 3.1 Service Call Classification

Classification	Description
Task management function	Initiates and terminates tasks
Task synchronization function	Suspends and resumes task execution and task event flag
Task exception processing function	Registers task exception processing routine, and requests, enables, and disables task exception
Synchronization and communication function	Manages semaphores, event flags, data queues, and mailboxes
Extended synchronization and communication function	Manages mutexes and message buffers
Memory pool management function	Allocates memory dynamically
Time management function	Notifies the time to the kernel, sets and references the system clock, and defines the timer handler
System status management function	Shifts to the CPU-locked state or dispatch-disabled state
Interrupt management function	Defines the interrupt handler, and changes and references the interrupt mask
Service call management function	Defines and calls the extended service calls
System configuration management function	Defines CPU exception handler and references the configuration information
Cache support function (HI7700/4 and HI7750/4)	Flushes, clears, and invalidates cache

3.2 Service Call Interface

Service calls can be called from programs written in C or assembly language. This section describes how to issue service calls.

3.2.1 C Language API

(1) Header File

Header file `kernel.h` must be included. `kernel.h` can be found in the `hihead` folder. For details on the header file, refer to section 4.1, Header Files.

(2) Calling Form

All service calls are described in the following C language function call format.

```
#include "kernel.h"
/* ... */
ercd = act_tsk(1);
```

(3) Basic Data Type

The basic data type defined in the HI7000/4 series are shown in the table 3.2.

Table 3.2 Basic Data Type

No.	Data Type	Meaning	No.	Data Type	Meaning
1	B	8-bit signed integer	21	PRI	16-bit signed integer
2	H	16-bit signed integer	22	SIZE	32-bit unsigned integer
3	W	32-bit signed integer	23	TMO	32-bit signed integer
4	UB	8-bit unsigned integer	24	RELTIM	32-bit unsigned integer
5	UH	16-bit unsigned integer	25	SYSTEM	A structure which contains the following members
6	UW	32-bit unsigned integer			Upper: 16-bit unsigned integer
7	VB	8-bit signed integer *			Lower: 32-bit unsigned integer
8	VH	16-bit signed integer *	26	VP_INT	32-bit signed integer *
9	VW	32-bit signed integer *	27	ER_BOOL	32-bit signed integer
10	VP	pointer to void type	28	ER_ID	32-bit signed integer
11	FP	pointer to void type function	29	ER_UINT	32-bit signed integer
12	INT	32-bit signed integer	30	TEXPTN	32-bit unsigned integer
13	UINT	32-bit unsigned integer	31	FLGPTN	32-bit unsigned integer
14	BOOL	32-bit signed integer	32	RDVPTN	32-bit unsigned integer
15	FN	32-bit signed integer	33	RDVNO	32-bit unsigned integer
16	ER	32-bit signed integer	34	OVRTIM	32-bit unsigned integer
17	ID	16-bit signed integer	35	INHNO	32-bit unsigned integer
18	ATR	32-bit unsigned integer	36	EXCNO	32-bit unsigned integer
19	STAT	32-bit unsigned integer	37	IMASK	32-bit unsigned integer
20	MODE	32-bit unsigned integer			

Note: When the variable values of these data types are referred to or substituted, the type must be explicitly converted (casted).

3.2.2 Assembly Language API

In most cases, a service call can be called from an assembly-language program, as shown in figure 3.1. Offsets must be specified as #OFF_XXX_XXX, where XXX_XXX is the service call name in uppercase characters.

```

        .INCLUDE "kernel.inc" ----- (a)
        .IMPORT __kernel_cnfgtbl ----- (b)
_task:
; .....
        MOV.L  #OFF_ACT_TSK,R0 ----- (c)
        MOV.L  #__kernel_cnfgtbl,R1
        MOV.L  @(R0,R1),R0 ----- (d)
        MOV.L  #1,R4 ----- (e)
        JSR   @R0 ----- (f)
        NOP
        ; ----- (g)

```

Figure 3.1 Example of Service Call from an Assembly-Language Program

- (a) Standard header file kernel.inc is included.
- (b) Service call entry table of the kernel is externally referenced.
- (c) Offset value corresponding to the service call must be specified.
- (d) Entry address of the service call to be called must be found.
- (e) Parameters must be specified.
- (f) Service call function is called.
- (g) After service call processing, execution returns to the address specified by the PR register except for the service calls that do not return to the calling program. In this example, execution returns to this location. When execution returns, normal end (E_OK) or an error code is set in R0.

When using SH-2A or SH2A-FPU, you can choose "Only for service call" as CFG_TBR in the configurator. In this case, the TBR register is used for calling kernel. In most cases, a service call can be called using TBR register from an assembly-language program, as shown in. Displacement must be specified as #INDEX_XXX_XXX, where XXX_XXX is the service call name in uppercase characters.

```

        .INCLUDE "kernel.inc" ----- (a)
_task:
;.....
        MOV.L   #1, R4 ----- (b)
        JSR/N   @@(INDEX_ACT_TSK, TBR) -- (c)
        NOP
; ----- (d)

```

Figure 3.2 Example of Service Call using TBR Register (SH-2A, SH2A-FPU)

- (a) Standard header file kernel.inc is included.
- (b) Parameters must be specified.
- (c) Service call function is called.
- (d) After service call processing, execution returns to the address specified by the PR register except for the service calls that do not return to the calling program. In this example, execution returns to this location. When execution returns, normal end (E_OK) or an error code is set in R0.

3.2.3 Guarantee of Register Contents after Issuing Service Call

Some registers guarantee the contents after a service call is issued but the others do not. This rule is based on that of the Renesas C compiler. The details are shown below.

Table 3.3 Guarantee of Register Contents after Issuing Service Call

Register	Register State after Service Call Returned
SR, R8 to R15, PR, GBR, MACH, MACL	The register contents will be guaranteed. IMASK bits in the SR register are updated when a service call chg_ims, ichg_ims, loc_cpu, iloc_cpu, unl_cpu, or iunl_cpu is called.
R0	Normal end (E_OK) or an error code is set.
R1 to R7	The register contents will be guaranteed only when a service call is clearly shown as a return parameter.
For SH2-DSP and SH3-DSP and SH4AL-DSP: DSR, RS, RE, MOD, A0, A0G, A1, A1G, M0, M1, X0, X1, Y0, Y1	The register contents will be guaranteed in the following situation. <ul style="list-style-type: none"> • A service call is issued from a task with TA_COP0 attribute or task exception processing routine • A service call is issued in a state mentioned in the note on the following page
For SH-4 and SH-4A: FPSCR	The register contents will be guaranteed.

Table 3.3 Guarantee of Register Contents after Issuing Service Call (cont)

Register	Register State after Service Call Returned
For SH-4 and SH-4A: FR0 to FR11 (DR0 to DR10, FV0 to FV8)	The register contents will not be guaranteed.
For SH-4 and SH-4A: FR12 to FR15 (DR12 to DR14, FV12), FPUL	The register contents will be guaranteed in the following situation. <ol style="list-style-type: none"> (1) When FR in the FPSCR register = 0 <ul style="list-style-type: none"> • A service call is issued from a task with TA_COP1 attribute or task exception processing routine • A service call is issued in a state mentioned in the note below (2) When FR in the FPSCR register = 1 <ul style="list-style-type: none"> • A service call is issued from a task with TA_COP2 attribute or task exception processing routine • A service call is issued in a state mentioned in the note below
For SH-4 and SH-4A: XF0 to XF15 (XD0 to XD14, XMTRX)	The register contents will be guaranteed in the following situation. <ol style="list-style-type: none"> (1) When FR in the FPSCR register = 0 <ul style="list-style-type: none"> • A service call is issued from a task with TA_COP2 attribute or task exception processing routine • A service call is issued in a state mentioned in the note below (2) When FR in the FPSCR register = 1 <ul style="list-style-type: none"> • A service call is issued from a task with TA_COP1 attribute or task exception processing routine • A service call is issued in a state mentioned in the note below
For SH-2A and SH2A-FPU: TBR	If "Use for only service call" or "Task context" is selected as CFG_TBR, the TBR is guaranteed. Refer to section 4.2.8, TBR Register (SH-2A, SH2A-FPU).
For SH2A-FPU: FR0 to FR11	The register contents will not be guaranteed.
For SH2A-FPU: FPSCR, FPUL, FR12 to FR15	The register contents will be guaranteed in the following situation. <ul style="list-style-type: none"> • A service call is issued from a task with TA_COP1 attribute or task exception processing routine • A service call is issued in a state mentioned in the note below

Note: Non-task context or dispatch-disabled state

For details on guarantee of the register contents when creating tasks and handlers, refer to section 4, Application Program Creation.

3.2.4 Return Value of Service Call and Error Code

For service calls that have return codes, a positive value or 0 (E_OK) indicates normal end, and a negative value indicates an error code. However, for service calls that have a BOOL-type return value, this is not the case. The meaning of the return value at normal end differs depending on the service call; however, only E_OK is returned at normal end for many service calls.

An error code consists of main error codes (lower 8 bits) and sub error codes (upper bits above lower 8 bits). The sub error code of this kernel is always set to -1.

The following macros are defined in the standard header `itron.h`. The `SERCD` macro of this kernel always returns -1 except for normal end.

- `ER mercd = MERCD(ER ercd)`; returns the main error code from the error code
- `ER sercd = SERCD(ER ercd)`; returns the sub error code from the error code

If a service call is issued while it is not selected through the configurator, error `E_NOSPT` is returned regardless of the return value type of the service call.

3.2.5 System State and Service Calls

Whether a service call can be called or not depends on the system state (refer to section 2.4, System State).

(1) Task Context and Non-Task Context

Service calls can be classified as dedicated to task context, dedicated to the non-task context, and service calls that can be called from all contexts.

- (a) The names of service calls that can be called from non-task context start with "i".
- (b) Following service calls can be called from all context.

- `sns_tex`
- `sns_ctx`
- `sns_loc`
- `sns_dsp`
- `sns_dpn`
- `vsta_knl, ivsta_knl *`
- `vsys_dwn, ivsys_dwn *`
- `vini_cac, ivini_cac *`
- `vclr_cac, ivclr_cac *`
- `vfls_cac, ivfls_cac *`
- `vinv_cac, ivinv_cac *`

* Although the names of these service calls start with “i”, these service calls can be called from task context.

(c) Service calls other than the above are service calls that are dedicated to task context. Normal system operation cannot be guaranteed when a service call is called from a context that differs from the above description. However, in special cases, for example when a service call that shifts to the WAITING state is called from non-task context, an E_CTX error is returned.

(2) Dispatch-disabled/-enabled State

All service calls can be called from dispatch-enabled state. Some service calls that shift to WAITING state cannot be called from dispatch-disabled state. When those service calls are called from dispatch-disabled state, an E_CTX error is returned.

(3) CPU-locked/-unlocked State

All service calls can be called from the CPU-unlocked state. Service calls that can be called from the CPU-locked state are listed below. Normal system operation cannot be guaranteed when service calls other than these are called from the CPU-locked state. When service calls that shift to the WAITING state are called, an E_CTX error is returned.

- ext_tsk
- exd_tsk
- sns_tex
- loc_cpu, iloc_cpu
- unl_cpu, iunl_cpu
- sns_ctx
- sns_loc
- sns_dsp
- sns_dpn
- vsta_knl, ivsta_knl
- vsys_dwn, ivsys_dwn

(4) CPU Exception Handler

Service calls that can be called from the CPU exception handler are listed below. Normal system operation cannot be guaranteed when service calls other than these are called from the CPU exception handler. When service calls that shift to the WAITING state are called, an E_CTX error is returned.

- sns_tex
- sns_ctx
- sns_loc
- sns_dsp
- sns_dpn
- get_tid, iget_tid
- ras_tex, iras_tex
- vsta_knl, ivsta_knl
- vsys_dwn, ivsys_dwn

(5) Before Kernel Activation

The following service calls can be called even before kernel activation (vsta_knl service call).

- vsta_knl, ivsta_knl
- vsys_dwn, ivsys_dwn
- vini_cac, ivini_cac
- HI7700/4: vclr_cac, ivclr_cac
- HI7700/4: vfls_cac, ivfls_cac
- HI7700/4: vinv_cac, ivinv_cac

3.2.6 Service Calls not in the μ ITRON4.0 Specification

Service calls whose name start with “v” or “iv”, such as vscr_tsk and ivbgn_int, are service calls that are not defined in the μ ITRON4.0 specification.

The following "ixxx_yyy"-format service calls (starting with "i") are not defined in the μ ITRON4.0 specification. They are provided to enable the "xxx_yyy"-format service calls corresponding to the following service calls to be issued in a non-task context because the "xxx_yyy"-format service calls are defined to be issued only in a task context in the μ ITRON4.0 specification.

icre_tsk, iacre_tsk, ista_tsk, ichg_pri, iget_pri, iref_tsk, iref_tst, isus_tsk, irsm_tsk, frsm_tsk, ideo_tsk, iref_tsk, icre_sem, iacre_sem, ipol_sem, iref_sem, icre_flg, iacre_flg, iclr_flg, ipol_flg, iref_flg, icre_dtq, iacre_dtq, iref_dtq, icre_mbx, iacre_mbx, isnd_mbx, iprcv_mbx, iref_mbx, icre_mbf, iacre_mbf, ipsnd_mbf, iref_mbf, icre_mpf, iacre_mpf, ipget_mpf, iref_mpf, icre_mpl, iacre_mpl, ipget_mpl, iref_mpl, iset_tim, iget_tim, icre_cyc, iacre_cyc, ista_cyc, istp_cyc, iref_cyc, iacre_alm, iacre_alm, ista_alm, istp_alm, iref_alm, ista_ovr, istp_ovr, iref_ovr, ideo_inh, ichg_ims, iget_ims, ideo_svc, ideo_exc, iref_cfg, iref_ver

3.3 Service Call Description Form

Service calls are described in details as shown below in this section.

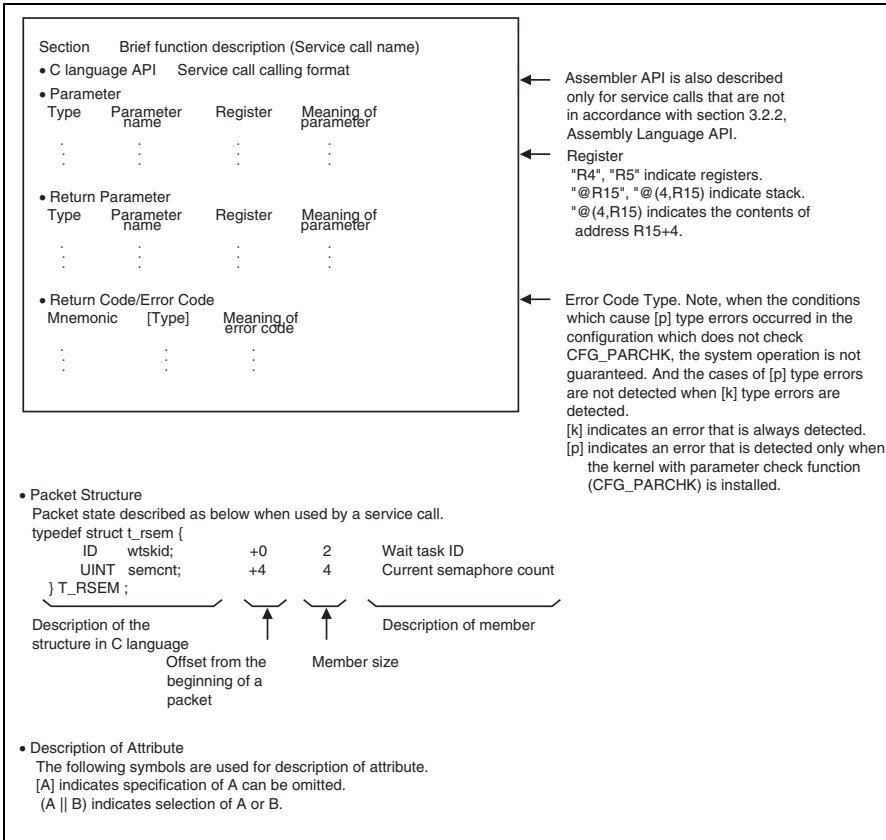

Figure 3.3 Service Call Description Form

3.4 Task Management

Task-Management Service Calls: Tasks are managed by the service calls listed in table 3.4.

Table 3.4 Service Calls for Task Management

Service Call ¹	Description	System State ²
		T/E/D/U/L/C
cre_tsk [s]	Creates task using dynamic stack	T/E/D/U
icre_tsk		N/E/D/U
vscr_tsk [s]	Creates task using static stack	T/E/D/U
ivscr_tsk		N/E/D/U
acre_tsk	Creates task and assigns task ID automatically	T/E/D/U
iacre_tsk		N/E/D/U
del_tsk	Deletes task	T/E/D/U
act_tsk [S]	Initiates task	T/E/D/U
iact_tsk [S]		N/E/D/U
can_act [S]	Cancel task initiation request	T/E/D/U
ican_act		N/E/D/U
sta_tsk	Initiates task and specifies start code	T/E/D/U
ista_tsk		N/E/D/U
ext_tsk [S]	Exits current task	T/E/D/U/L
exd_tsk [S]	Exits and deletes current task	T/E/D/U/L
ter_tsk [S]	Forcibly terminates a task	T/E/D/U
chg_pri [S]	Changes task priority	T/E/D/U
ichg_pri		N/E/D/U
get_pri [S]	Refers to task priority	T/E/D/U
iget_pri		N/E/D/U
ref_tsk	Refers to task state	T/E/D/U
iref_tsk		N/E/D/U
ref_tst	Refers to task state (simple version)	T/E/D/U
iref_tst		N/E/D/U
vchg_tmd	Changes task execution mode	T/E/D/U

Notes: 1. [S]: Standard profile service calls

[s]: Service calls that are not standard profile service calls but are needed in order to use the standard profile function

2. T: Can be called from task context
 N: Can be called from non-task context
 E: Can be called from dispatch-enabled state
 D: Can be called from dispatch-disabled state
 U: Can be called from CPU-unlocked state
 L: Can be called from CPU-locked state
 C: Can be called from CPU exception handler

Task Management Specifications: Task management specifications are listed in table 3.5.

Table 3.5 Task Management Specifications

Item	Description
Task ID	1 to CFG_MAXTSKID (1023 max.)
Task priority	1 to CFG_MAXTSKPRI (255 max.)
Maximum count of task initiation request	15
Task attribute	TA_HLNG: The task is written in a high-level language TA_ASM: The task is written in assembly language TA_ACT: The task makes a transition to the READY state after the task has been created [HI7000/4, HI7700/4] TA_COP0: The task uses the DSP [HI7000/4] TA_COP1: The task uses the FPU [HI7750/4] TA_COP1: The task uses bank 0 in the FPU TA_COP2: The task uses bank 1 in the FPU

Note: This value is the same as TMAX_TPRI defined in kernel_macro.h.

3.4.1 Create Task

<Using Dynamic Stack>

(cre_tsk, icre_tsk)

(acre_tsk, iacre_tsk: Assign Task ID Automatically)

<Using Static Stack>

(vscr_tsk, ivscr_tsk)

C-Language API:

```
ER ercd = cre_tsk(ID tskid, T_CTSK *pk_ctsk);
ER ercd = icre_tsk(ID tskid, T_CTSK *pk_ctsk);
ER_ID tskid = acre_tsk(T_CTSK *pk_ctsk);
ER_ID tskid = iacre_tsk(T_CTSK *pk_ctsk);
ER ercd = vscr_tsk(ID tskid, T_CTSK *pk_ctsk);
ER ercd = ivscr_tsk(ID tskid, T_CTSK *pk_ctsk);
```

Parameters:

```
<cre_tsk, icre_tsk, vscr_tsk, ivscr_tsk>
ID          tskid          R4   Task ID
T_CTSK      *pk_ctsk      R5   Pointer to the packet where task creation
                                information is stored

<acre_tsk, iacre_tsk>
T_CTSK      *pk_ctsk      R4   Pointer to the packet where task creation
                                information is stored
```

Return Parameters:

```
<cre_tsk, icre_tsk, vscr_tsk, ivscr_tsk>
ER          ercd          R0   Normal end (E_OK) or error code

< acre_tsk, iacre_tsk >
ER_ID      tskid         R0   Created task ID (a positive value) or error
                                code
```

Packet Structure:

```
typedef struct t_ctsk{
    ATR      tskatr;      0    4    Task attribute
    VP_INT   exinf;      +4   4    Extended information
    FP       task;       +8   4    Task start address
    PRI      itskpri;    +12  2    Priority at task initiation
    SIZE     stksz;     +16  4    Task stack size
    VP       stk;       +20  4    Start address of task stack area
}T_CTSK;
```

Error Codes:

E_NOMEM	[k]	Insufficient memory (Task stack area cannot be allocated in the memory)
E_RSATR	[p]	Invalid attribute (tskatr is invalid)
E_PAR	[p]	Parameter error (pk_ctsk is other than a multiple of four, task is an odd address, stksz is other than a multiple of four, stksz = 0, stksz ≥ H'80000000, itskpri ≤ 0, itskpri > CFG_MAXTSKPRI, or stk is other than a multiple of four if stk is not NULL)
E_ID	[p]	Invalid ID number (tskid ≤ 0, tskid > CFG_MAXTSKID (cre_tsk or icre_tsk), tskid ≤ CFG_STSTKID (cre_tsk or icre_tsk), or tskid > CFG_STSTKID (vscre_tsk or ivscre_tsk))
E_OBJ	[k]	The object state is invalid (The task specified by tskid is not in the DORMANT state or the current task is specified)
E_NOID	[k]	No ID available

Function:

The service calls cre_tsk, icre_tsk, acre_tsk, and iacre_tsk create tasks that use dynamic stacks and service calls vscre_tsk and ivscre_tsk create tasks that use static stacks. The created tasks make a transition to the DORMANT state when the TA_ACT attribute is not specified, or to the READY state when the TA_ACT attribute is specified.

The processing that is performed at task creation is listed in table 3.6.

Table 3.6 Processing to be Performed at Task Creation**Contents**

Clears the number of task initiation request queues
Sets the state for which the task exception routine is not defined
Sets the state for which the upper-limit processor time is not specified
Assigns the stack (for cre_tsk and acre_tsk)

The following describes the meaning of the parameters.

tskid: The service calls `vscr_tsk` and `ivscr_tsk` create tasks that use static stacks. 1 to `CFG_STSTKID` can be specified for `tskid`. The service calls `cre_tsk` and `icre_tsk` create tasks that use dynamic stacks. `CFG_STSTKID + 1` to `CFG_MAXTSKID` can be specified for `tskid`. The service calls `acre_tsk` and `iacre_tsk` detect an undefined task ID and create a task for the task ID with the contents specified by `pk_ctsk` and return the ID as a return parameter. The service calls `acre_tsk` and `iacre_tsk` create tasks that use dynamic stacks. The task ID range to be detected is `CFG_STSTKID + 1` to `CFG_MAXTSKID`.

tskatr: The parameter `tskatr` specifies the coprocessor and language in which the task was written in the following format. See table 3.7 for details.

```
tskatr:= ( (TA_HLNG || TA_ASM) [ | TA_ACT] [ | TA_COP0] [ | TA_COP1] [ |
TA_COP2] )
```

Table 3.7 Task Attributes (tskatr)

tskatr	Code	Description
TA_HLNG	H'00000000	The task is written in a high-level language
TA_ASM	H'00000001	The task is written in assembly language
TA_ACT	H'00000002	The task makes a transition to the READY state after the task has been created
TA_COP0	H'00000100	The task uses the DSP (HI7000/4, HI7700/4)
TA_COP1	H'00000200	The task uses the FPU (HI7000/4) The task uses bank 0 in the FPU (HI7750/4) *
TA_COP2	H'00000400	The task uses bank 1 in the FPU (HI7750/4) *

Note The initial value of the FPSCR register is H'00040001 (bank 0).

When `TA_ACT` attribute is specified, extended information (`exinf`) is passed to the task as a parameter.

By specifying `TA_COPn` attribute, the registers of the selected coprocessor can be saved as task context. Note that the `TA_COPn` attribute is not in the μ ITRON4.0 specification.

exinf: The parameter `exinf` can be widely used by the user, for example, to set information concerning tasks to be created.

task: Specify the task start address.

itskpri: Specify 1 to `CFG_MAXTSKPRI` as the task priority at initiation.

stksz: Parameter stksz is valid only for service calls cre_tsk, icre_tsk, acre_tsk, and iacre_tsk and specifies the stack size of the task to be created. A multiple of four can be specified for the stack size.

Note that stksz has no meaning to service calls vschr_tsk and ivschr_tsk because each service call creates a task that uses the static stack. The parameter stksz is ignored in kernel processing.

stk: stk is effective in cre_tsk, icre_tsk, acre_tsk, and iacre_tsk service calls.

When NULL is specified as stk, the kernel allocates a stack in the dynamic stack area (CFG_TSKSTKSZ). After the task has been created, the dynamic stack area size will decrease by an amount given by the following expression:

$$\text{Decrease in size} = \text{stksz} + 16 \text{ bytes}$$

The stack area address allocated by application can be specified as stk. In this case, allocate a stack area for the size specified by stksz and specify the start address of the area.

The service calls vschr_tsk and ivschr_tsk are functions original to the HI7000/4 series.

3.4.2 Delete Task (del_tsk)

C-Language API:

```
ER ercd = del_tsk(ID tskid);
```

Parameters:

ID	tskid	R4	Task ID
----	-------	----	---------

Return Parameters:

ER	ercd	R0	Normal end (E_OK) or error code
----	------	----	---------------------------------

Error Codes:

E_ID	[p]	Invalid ID number (tskid ≤ 0 or tskid > CFG_MAXTSKID)
E_NOEXS	[k]	Undefined (Task indicated by tskid does not exist)
E_OBJ	[k]	Object state is invalid (Task indicated by tskid is not in DORMANT state or the current task is specified)
E_CTX	[k]	Context error (Called from the disabled system state)

Function:

The service call del_tsk deletes the task indicated by the parameter tskid. The deleted task makes a transition to the NON-EXISTENT state.

If a dynamic stack is used by the task specified by tskid, the stack is returned to the dynamic stack area. As a result, the free dynamic stack area size increases by an amount given by the following expression:

Increase in size = (stksz specified at task creation) + 16 bytes

3.4.3 Initiate Task (act_tsk, iact_tsk)

C-Language API:

```
ER ercd = act_tsk(ID tskid);
ER ercd = iact_tsk(ID tskid);
```

Parameters:

ID	tskid	R4	Task ID
----	-------	----	---------

Return Parameters:

ER	ercd	R0	Normal end (E_OK) or error code
----	------	----	---------------------------------

Error Codes:

E_ID	[p]	Invalid ID number (tskid ≤ 0, tskid > MAXTSKID, or tskid = TSK_SELF(0) is specified in a non-task context)
E_NOEXS	[k]	Undefined (Task indicated by tskid does not exist)
E_QOVR	[k]	Queuing overflow (actcnt > 15)

Function:

Each service call initiates the task indicated by the parameter tskid. The initiated task makes a transition from the DORMANT state to the READY state.

The processing that is performed during task activation is listed in table 3.8.

Table 3.8 Processing to be Performed during Task Initiation

Contents

Initiates base priority and current priority of the task
Clears the number of start request queues
Clears the number of suspend request nestings
Clears reserved exception factors
Sets task exception processing disabled state
Clears flag patterns of the task event flag

By specifying tskid = TSK_SELF (0), the current task is specified.

Extended information of the task specified at task creation will be passed to the task as the parameter.

If the static stack of the task indicated by tskid is not being used by any task when the service calls act_tsk and iact_tsk are called (tskid = 1 to CFG_STSTKID), the task indicated by tskid occupies the shared stack and shifts to the READY state.

If the stack is being used by another task, the task indicated by tskid shifts to the WAITING state and is placed in the shared-stack wait queue since the stack area cannot be used. The wait queue is managed on a first-in first-out (FIFO) basis.

When the task is not in the DORMANT state, up to 15 task initiation requests from the service calls `act_tsk` and `iact_tsk` can be stored.

3.4.4 Cancel Task Initiation Request (`can_act`, `ican_act`)

C-Language API:

```
ER_UINT actcnt = can_act(ID tskid);  
ER_UINT actcnt = ican_act(ID tskid);
```

Parameters:

ID	tskid	R4	Task ID
----	-------	----	---------

Return Parameters:

ER_UINT	actcnt	R0	Number of cached initiation requests (positive value or 0), or error code
---------	--------	----	---------------------------------------------------------------------------

Error Codes:

E_ID	[p]	Invalid ID number (<code>tskid < 0</code> , <code>tskid > CFG_MAXTSKID</code> , or <code>tskid = TSK_SELF(0)</code> is specified in a non-task context)
E_NOEXS	[k]	Undefined (Task indicated by <code>tskid</code> is not created)

Function:

The number of initiation requests queued for the task specified by `tskid` is determined, the result is returned as the return parameter, and at the same time the initiation requests are all cancelled.

By specifying `tskid=TSK_SELF(0)`, the current task is specified.

A task in a DORMANT state can also be specified; in this case the return parameter is 0.

3.4.5 Start Task (Start Code Specified) (sta_tsk, ista_tsk)

C-Language API:

```
ER ercd = sta_tsk(ID tskid, VP_INT stacd);
ER ercd = ista_tsk(ID tskid, VP_INT stacd);
```

Parameters:

ID	tskid	R4	Task ID
VP_INT	stacd	R5	Task initiation code

Return Parameters:

ER	ercd	R0	Normal end (E_OK) or error code
----	------	----	---------------------------------

Error Codes:

E_ID	[p]	Invalid ID number (tskid ≤ 0, tskid > CFG_MAXTSKID)
E_NOEXS	[k]	Undefined (Task indicated by tskid does not exist)
E_OBJ	[k]	Object state is invalid (The task specified by tskid is not in the DORMANT state or the current task is specified)

Function:

Each service call initiates the task indicated by the parameter tskid. The initiated task makes a transition from the DORMANT state to the READY state. At this time, the processing to be performed during task initiation (table 3.8) is performed. The task initiation code indicated by the parameter stacd will be passed to the initiated task as the parameter.

If the static stack of the task indicated by tskid is not being used by any task when the service calls sta_tsk and ista_tsk are called, the task indicated by tskid occupies the shared stack and shifts to the READY state.

If the stack is being used by another task, the task indicated by tskid shifts to the WAITING state and is placed in the shared-stack wait queue since the stack area cannot be used. The wait queue is managed on a first-in first-out (FIFO) basis.

3.4.6 Exit Current Task, Exit and Delete Current Task (ext_tsk), (exd_tsk)

C-Language API:

```
void ext_tsk(void);  
void exd_tsk(void);
```

Parameters:

None

Return Parameters:

The service calls ext_tsk and exd_tsk do not return to the current task. However, if the service call ext_tsk or exd_tsk is called without being installed at system creation, error code E_RSFN is set in R0 and returned. In addition, the service calls ext_tsk and exd_tsk may generate the following error, and in this case, control is passed to the system down routine.

E_CTX	[k]	Context error (Called from disabled system state)
-------	-----	---------------------------------------------------

Function:

The service call ext_tsk exits the current task normally. After the execution of the service call ext_tsk, the current task makes a transition from the RUNNING state to the DORMANT state. When initiation request is queued, the service call ext_tsk exits the current task and then restarts the task.

The processing that is performed at task termination is listed in table 3.9.

Table 3.9 Processing to be Performed at Task Termination

Contents

Unlocks the mutex locked by the task

Releases upper-limit processor time

The service call exd_tsk exits the current task normally and deletes it. After the execution of the service call exd_tsk, the current task makes a transition from the RUNNING state to the NON-EXISTENT state.

Service calls ext_tsk and exd_tsk do not release resources other than mutexes (such as semaphores and memory blocks) acquired before the task is exited. Therefore, the user must call service calls to release resources before exiting the task.

If the task that issues the service calls `ext_tsk` and `exd_tsk` shares the stack with other tasks, the task at the head of the stack wait queue is removed and WAITING state is cancelled. At this time, the processing to be performed during task initiation (table 3.8) is performed for the task that is removed from the stack wait queue and the task makes a transition to the READY state.

If a dynamic stack is used by the task that called the service call `exd_tsk`, the stack is returned to the dynamic stack area. As a result, the free dynamic stack area size increases by an amount given by the following expression:

$$\text{Increase in size} = (\text{stksz which is specified at creation}) + 16 \text{ bytes}$$

Service calls `ext_tsk` and `exd_tsk` can be called while task dispatch is disabled or the CPU is locked. After either of the service calls is called, the dispatch-disabled state or CPU-locked state is cancelled.

Note that when the task returns from the start function, the same operation as for service call `ext_tsk` will be performed.

3.4.7 Terminate Task (ter_tsk)

C-Language API:

```
ER ercd = ter_tsk(ID tskid);
```

Parameters:

ID	tskid	R4	Task ID
----	-------	----	---------

Return Parameters:

ER	ercd	R0	Normal end (E_OK) or error code
----	------	----	---------------------------------

Error Codes:

E_ID	[p]	Invalid ID number ($tskid \leq 0$ or $tskid > CFG_MAXTSKID$)
E_NOEXS	[k]	Undefined (Task indicated by tskid does not exist)
E_OBJ	[k]	Object state is invalid (Task indicated by tskid is in the DORMANT state)
E_ILUSE	[k]	Illegal use of service call (The current task is specified as the object task)
E_CTX	[k]	Context error (Called from disabled system state)

Function:

The service call `ter_tsk` forces a task specified by `tskid` to terminate. The terminated task enters the DORMANT state. At this time, the processing shown in table 3.9 is performed.

When the initiation request is queued, the processing to be performed during task initiation is performed, and the target task enters the READY state.

A request from a task to force another task to terminate is delayed in the following cases:

- If the task specified by `tskid` is masking requests from other tasks to force tasks to terminate by calling service call `vchg_tmd`

The service call `ter_tsk` does not release resources other than the mutexes (such as semaphores and memory blocks) acquired before the task is terminated. Therefore, the user must call service calls to release resources before calling the service call `ter_tsk`.

If the task specified by `tskid` shares the stack with other tasks, the task at the head of the stack wait queue is removed and released from the WAITING state. At this time, the processing to be performed during task initiation (table 3.8) is performed for the task that is removed from the stack wait queue and the task makes a transition to the READY state.

3.4.8 Change Task Priority (chg_pri, ichg_pri)

C-Language API:

```
ER ercd = chg_pri(ID tskid, PRI tskpri);
ER ercd = ichg_pri(ID tskid, PRI tskpri);
```

Parameters:

ID	tskid	R4	Task ID
PRI	tskpri	R5	Base priority of task

Return Parameters:

ER	ercd	R0	Normal end (E_OK) or error code
----	------	----	---------------------------------

Error Codes:

E_PAR	[p]	Parameter error (tskpri < 0 or tskpri > CFG_MAXTSKPRI)
E_ID	[p]	Invalid ID number (tskpri < 0, tskid > CFG_MAXTSKID, or tskid = TSK_SELF(0) is specified in a non-task context)
E_NOEXS	[k]	Undefined (Task specified by tskid does not exist)
E_ILUSE	[k]	Illegal use of service call (Upper-limit priority is exceeded)
E_OBJ	[k]	Object state is invalid (Task is in the DORMANT state)

Function:

Each service call changes the base task priority specified by the parameter tskid to the value specified by the parameter tskpri. The current task priority is also changed. By specifying tskid = TSK_SELF (0), the current task can also be specified.

Specifying tskpri = TPRI_INI (0) returns the task priority to the initial priority that was specified at task creation.

A priority changed by the service calls is valid until the task is terminated or until the service calls are called again. When a task makes a transition to the DORMANT state, the task priority before termination becomes invalid and returns to the initial task priority specified at task creation.

If the task specified by tskid is in the WAITING state and TA_TPRI is specified for the object attribute, the wait queue can be changed by the service calls and as a result, the task at the head of the wait queue may be released from the WAITING state.

If the base priority specified in the parameter tskpri is higher than the upper-limit priority of one of the mutexes when the object task locks or waits to lock the mutexes with the TA_CEILING attribute, E_ILUSE is returned.

3.4.9 Refer to Task Priority (get_pri, iget_pri)

C-Language API:

```
ER ercd = get_pri(ID tskid, PRI *p_tskpri);
```

```
ER ercd = iget_pri(ID tskid, PRI *p_tskpri);
```

Parameters:

ID	tskid	R4	Task ID
PRI	*p_tskpri	R5	Pointer to the area where the current priority of the object task is to be returned

Return Parameters:

ER	ercd	R0	Normal end (E_OK) or error code
PRI	*p_tskpri	R5	Pointer to the area where the current priority of the object task is stored

Error Codes:

E_PAR	[p]	Parameter error (p_tskpri is not even)
E_ID	[p]	Invalid ID number (tskid < 0, tskid > CFG_MAXTSKID, or tskid = TSK_SELF(0) is specified in a non-task context)
E_NOEXS	[k]	Undefined (Task specified by tskid does not exist)
E_OBJ	[k]	Object status is invalid (Task is in the DORMANT state)

Function:

Each service call refers to the current priority of the task specified by the parameter tskid, and returns it to area indicated by parameter p_tskpri. By specifying tskid = TSK_SELF (0), the current task is specified.

3.4.10 Refer to Task State (ref_tsk, iref_tsk)

C-Language API:

```
ER ercd = ref_tsk(ID tskid , T_RTsk *pk_rtsk);
ER ercd = iref_tsk(ID tskid , T_RTsk *pk_rtsk);
```

Parameters:

ID	tskid	R4	Task ID
T_RTsk	*pk_rtsk	R5	Pointer to the packet where the task state is to be returned

Return Parameters:

ER	ercd	R0	Normal end (E_OK) or error code
T_RTsk	*pk_rtsk	R4	Pointer to the packet where the task state is stored

Packet Structure:

```
typedef struct t_rtsk {
    STAT  tskstat; +0  4  Task state
    PRI   tskpri;  +4  2  Current priority of the task
    PRI   tskbpri; +6  2  Base priority of the task
    STAT  tskwait; +8  4  Wait cause
    ID    wobjid;  +12 2  Wait object ID
    TMO   lefttmo; +16 4  Time to timeout
    UINT  actcnt;  +20 4  Number of queued initiation requests
    UINT  wupcnt;  +24 4  Number of queued wakeup requests
    UINT  suscnt;  +28 4  Suspend request nest count
    UINT  tskmode +32 4  Task execution mode
    UINT  tflptn;  +36 4  Current task event flag value
}T_RTsk;
```

Error Codes:

E_PAR	[p]	Parameter error (pk_rtsk is other than a multiple of four)
E_ID	[p]	Invalid ID number (tskid < 0, tskid > CFG_MAXTSKID, or tskid = TSK_SELF(0) is specified in a non-task context)
E_NOEXS	[k]	Undefined (Task indicated by tskid does not exist)

Function:

Each service call refers to the state of the task indicated by the parameter tskid, and then returns it to the area indicated by parameter pk_rtsk. By specifying tskid = TSK_SELF(0), the current task is specified.

The following values are returned to the area indicated by pk_rtsk. Note that data with an asterisk (*) is invalid when the task is in the DORMANT state. If referenced information is related to a function that is not installed, the referenced information will be undefined.

— tskstat

Indicates the current task state. The following values are returned.

Table 3.10 Current Task State (tskstat)

tskstat	Code	Description
TTS_RUN	H'00000001	RUNNING state
TTS_RDY	H'00000002	READY state
TTS_WAI	H'00000004	WAITING state
TTS_SUS	H'00000008	SUSPENDED state
TTS_WAS	H'0000000c	WAITING-SUSPENDED state
TTS_DMT	H'00000010	DORMANT state
TTS_STK	H'40000000	Shared-stack WAITING state

- tskpri
Indicates the current task priority. When the task is in the DORMANT state, the initial priority of the task is returned.
- tskbpri
Indicates the base priority of the task. When the task is in the DORMANT state, the initial priority of the task is returned.

— `tskwait*`

Valid only when `TTS_WAI` or `TTS_WAS` is returned to `tskstat` and the following values are returned.

Table 3.11 Cause of WAITING State (`tskwait`)

tskwait	Code	Description
<code>TTW_SLP</code>	H'00000001	Shifted to the WAITING state by <code>slp_tsk</code> or <code>tslp_tsk</code>
<code>TTW_DLY</code>	H'00000002	Shifted to the WAITING state by <code>dly_tsk</code>
<code>TTW_SEM</code>	H'00000004	Shifted to the WAITING state by <code>wai_sem</code> or <code>twai_sem</code>
<code>TTW_FLG</code>	H'00000008	Shifted to the WAITING state by <code>wai_flg</code> or <code>twai_flg</code>
<code>TTW_SDTQ</code>	H'00000010	Shifted to the WAITING state by <code>snd_dtq</code> or <code>tsnd_dtq</code>
<code>TTW_RDTQ</code>	H'00000020	Shifted to the WAITING state by <code>rcv_dtq</code> or <code>trcv_dtq</code>
<code>TTW_MBX</code>	H'00000040	Shifted to the WAITING state by <code>rcv_mbx</code> or <code>trcv_mbx</code>
<code>TTW_MTX</code>	H'00000080	Shifted to the WAITING state by <code>loc_mtx</code> or <code>tloc_mtx</code>
<code>TTW_SMBF</code>	H'00000100	Shifted to the WAITING state by <code>snd_mbf</code> or <code>tsnd_mbf</code>
<code>TTW_RMBF</code>	H'00000200	Shifted to the WAITING state by <code>rcv_mbf</code> or <code>trcv_mbf</code>
<code>TTW_MPF</code>	H'00002000	Shifted to the WAITING state by <code>get_mpf</code> or <code>tget_mpf</code>
<code>TTW_MPL</code>	H'00004000	Shifted to the WAITING state by <code>get_mpl</code> or <code>tget_mpl</code>
<code>TTW_TFL</code>	H'00008000	Shifted to the WAITING state by <code>vwai_tfl</code> or <code>vtwai_tfl</code>

— `wobjid*`

Valid only when `TTS_WAI` or `TTS_WAS` is returned to `tskstat` and the waiting target object ID is returned.

— `lefttmo*`

The time until the target task times out is returned. Note that when the target task is in the WAITING state according to the service call `dly_tsk`, the value is undefined.

— `actcnt*`

The current initiation request queue count is returned.

— `wupcnt*`

The current wakeup request queue count is returned.

— `suscnt*`

The current suspend request nesting count is returned.

— `tskmode*`

The task execution mode set in the service call `vchg_tmd`, and whether there is a request that is delayed by the service call `vchg_tmd`, are returned.

The following value is returned to `tskmode`.

Table 3.12 Task Execution Mode (`tskmode`)

tskmode	Code	Description
ECM_SUS	H'00000001	A suspend request is masked
ECM_TER	H'00000002	A forcible termination request is masked
PND_SUS	H'00000004	A suspend request is delayed
PND_TER	H'00000008	A forcible termination request is delayed

— `tflptn*`

The current task event flag value is returned. However, if the task event flag function was not installed at system creation, an undefined value is returned.

`tskmode` and `tflptn` are members not defined in the μ ITRON4.0 specification.

3.4.11 Refer to Task State (Simple Version) (ref_tst, iref_tst)**C-Language API:**

```
ER ercd = ref_tst(ID tskid , T_RTST *pk_rtst);
ER ercd = iref_tst(ID tskid , T_RTST *pk_rtst);
```

Parameters:

ID	tskid	R4	Task ID
T_RTST	*pk_rtst	R5	Start address of the packet where the task state is to be returned

Return Parameters:

ER	ercd	R0	Normal end (E_OK) or error code
T_RTST	*pk_rtst	R5	Start address of the packet where the task state is stored

Packet Structure:

```
typedef struct t_rtst {
    STAT tskstat; +0 4 Task state
    STAT tskwait; +4 4 Wait cause
}T_RTST;
```

Error Codes:

E_PAR	[p]	Parameter error (pk_rtsk is other than a multiple of four)
E_ID	[p]	Invalid ID number (tskid < 0, tskid > CFG_MAXTSKID, or tskid = TSK_SELF(0) is specified in a non-task context)
E_NOEXS	[k]	Undefined (Task indicated by tskid does not exist)

Function:

Each service call refers to the state and the case of WAITING state of the task indicated by the parameter tskid, and then returns it to the area indicated by parameter pk_rtst. By specifying tskid = TSK_SELF (0), the current task can be specified.

The following values are returned to the area indicated by pk_rtst. Note that data with an asterisk (*) is invalid when the task is in the DORMANT state. If referenced information is related to a function that is not installed, the referenced information will be undefined.

— `tskstat`

Indicates the current task state. The following values are returned.

Table 3.13 Current Task State (tskstat)

tskstat	Code	Description
TTS_RUN	H'00000001	RUNNING state
TTS_RDY	H'00000002	READY state
TTS_WAI	H'00000004	WAITING state
TTS_SUS	H'00000008	SUSPENDED state
TTS_WAS	H'0000000c	WAITING-SUSPENDED state
TTS_DMT	H'00000010	DORMANT state
TTS_STK	H'40000000	Shared-stack WAITING state

— `tskwait*`

Valid only when TTS_WAI or TTS_WAS is returned to `tskstat` and the following values are returned.

Table 3.14 Cause of WAITING State (tskwait)

tskwait	Code	Description
TTW_SLP	H'00000001	Shifted to the WAITING state by <code>slp_tsk</code> or <code>tslp_tsk</code>
TTW_DLY	H'00000002	Shifted to the WAITING state by <code>dly_tsk</code>
TTW_SEM	H'00000004	Shifted to the WAITING state by <code>wai_sem</code> or <code>twai_sem</code>
TTW_FLG	H'00000008	Shifted to the WAITING state by <code>wai_flg</code> or <code>twai_flg</code>
TTW_SDTQ	H'00000010	Shifted to the WAITING state by <code>snd_dtq</code> or <code>tsnd_dtq</code>
TTW_RDTQ	H'00000020	Shifted to the WAITING state by <code>rcv_dtq</code> or <code>trcv_dtq</code>
TTW_MBX	H'00000040	Shifted to the WAITING state by <code>rcv_mbx</code> or <code>trcv_mbx</code>
TTW_MTX	H'00000080	Shifted to the WAITING state by <code>loc_mtx</code> or <code>tloc_mtx</code>
TTW_SMBF	H'00000100	Shifted to the WAITING state by <code>snd_mbf</code> or <code>tsnd_mbf</code>
TTW_RMBF	H'00000200	Shifted to the WAITING state by <code>rcv_mbf</code> or <code>trcv_mbf</code>
TTW_MPF	H'00002000	Shifted to the WAITING state by <code>get_mpf</code> or <code>tget_mpf</code>
TTW_MPL	H'00004000	Shifted to the WAITING state by <code>get_mpl</code> or <code>tget_mpl</code>
TTW_TFL	H'00008000	Shifted to the WAITING state by <code>vwai_tfl</code> or <code>vtwai_tfl</code>

3.4.12 Change Task Execution Mode (vchg_tmd)

C-Language API:

```
ER ercd = vchg_tmd(UINT tmd);
```

Parameters:

```
UINT          tmd          R4    Task execution mode to change
```

Return Parameters:

```
ER          ercd          R0    Normal end (E_OK) or error code
```

Error Codes:

```
E_PAR          [p]    Parameter error (tmd is invalid)
E_CTX          [k]    Context error (Called from disabled system state)
```

Function:

The system call tmd changes the task execution mode. The execution mode can mask requests from other tasks as the task execution mode.

Table 3.15 Task Execution Mode (tmd)

tmd	Code	Description
ECM_SUS	H'00000001	A suspend request is masked
ECM_TER	H'00000002	A forcible termination request is masked

When the suspend request is masked, even if service calls sus_tsk and isus_tsk are called, their requests are delayed until the mask is cancelled (with tmd = 0 specified) by the service call vchg_tmd.

When the forced termination request is masked, even if the service call ter_tsk is called, its request is delayed until the mask is cancelled (with tmd = 0 specified) by the service call vchg_tmd.

In task execution mode, the state of the calling task is taken over as the task context in extended service call routines and task exception processing routines.

Delays of suspend requests and forced termination requests can be referenced through service calls ref_tsk and iref_tsk.

This service call is a function original to the HI7000/4 series.

3.5 Task Synchronization

Task Synchronization Service Calls: The service calls for task synchronization are listed in table 3.16.

Table 3.16 Task Synchronization Service Calls

Service Call ¹	Description	System State ²
		T/E/D/U/L/C
slp_tsk [S]	Shifts current task to the WAITING state	T/E/U
tslp_tsk [S]	Shifts current task to the WAITING state with timeout function	T/E/U
wup_tsk [S]	Wakes up task	T/E/D/U
iwup_tsk [S]		N/E/D/U
can_wup [S]	Cancels Wakeup Task	T/E/D/U
ican_wup		N/E/D/U
rel_wai [S]	Forcibly cancels the WAITING state	T/E/D/U
irel_wai [S]		N/E/D/U
sus_tsk [S]	Shifts the task to the SUSPENDED state	T/E/D/U
isus_tsk		N/E/D/U
rsm_tsk [S]	Resumes the execution of a task in the SUSPENDED state	T/E/D/U
irms_tsk		N/E/D/U
frsm_tsk [S]	Forcibly resumes the execution of a task in the SUSPENDED state	T/E/D/U
ifrm_tsk		N/E/D/U
dly_tsk [S]	Delays the current task	T/E/U
vset_tfl	Sets the task event flag	T/E/D/U
ivset_tfl		N/E/D/U
vclr_tfl	Clears the task event flag	T/E/D/U
ivclr_tfl		N/E/D/U
vwai_tfl	Waits for the task event flag	T/E/U
vpol_tfl	Polls and waits for the task event flag	T/E/D/U
vtwai_tfl	Waits for the task event flag with timeout function	T/E/U

Notes: 1. [S]: Standard profile service calls

[s]: Service calls that are not standard profile service calls but are needed in order to use the standard profile function

- 2. T: Can be called from task context
- N: Can be called from non-task context
- E: Can be called from dispatch-enabled state
- D: Can be called from dispatch-disabled state
- U: Can be called from CPU-unlocked state
- L: Can be called from CPU-locked state
- C: Can be called from CPU exception handler

Task Synchronization Specifications: The task synchronization specifications are listed in table 3.17.

Table 3.17 Task Synchronization Specifications

Item	Description
Maximum number of task wake-up request count	15
Maximum number of task suspend request nesting	15
Number of task event flag bits	32 bits (lower 16 bits are reserved for future expansion)
Initial value of task event flag	Initialized as 0 at task initiation
Wait condition of task event flag	Waits for a logical OR

3.5.1 Sleep Task (slp_tsk, tslp_tsk)

C-Language API:

```
ER ercd = slp_tsk(void);  
ER ercd = tslp_tsk(TMO tmout);
```

Parameters:

```
<tslp_tsk>  
TMO          tmout          R4  Timeout specification
```

Return Parameters:

```
ER          ercd          R0  Normal end (E_OK) or error code
```

Error Codes:

```
E_PAR      [p]  Parameter error (tmout ≤ -2)  
E_CTX      [k]  Context error (Called from disabled system state)  
E_TMOUT    [k]  Timeout  
E_RLWAI    [k]  WAITING state is forcibly cancelled  
              (rel_wai service call was issued in the WAITING state)
```

Function:

Each service call shifts the current task to the wake-up WAITING state. However, if wake-up requests are queued for the current task, the wake-up request count is decremented by one and task execution continues. The WAITING state is cancelled by the service calls wup_tsk and iwup_tsk.

The parameter tmout specified by service call tslp_tsk specifies the timeout period. If a positive value is specified for parameter tmout, the WAITING state is released and error code E_TMOUT is returned when the tmout period has passed without the wait release conditions being satisfied.

If tmout = TMO_POL (0) is specified, the task continues execution by decrementing the wake-up request count by one if the count is a positive value. If the wake-up request count is 0, error code E_TMOUT is returned.

If tmout = TMO_FEVR (-1) is specified, the same operation as for service call slp_tsk will be performed. In other words, timeout will not be monitored.

If a value larger than 1 is specified for CFG_TICDENO (the denominator for time tick cycles), the maximum value that can be specified for tmout is H'7ffffff/CFG_TICDENO. If a value larger than this is specified, operation is not guaranteed.

3.5.2 Wakeup Task (wup_tsk, iwup_tsk)

C-Language API:

```
ER ercd = wup_tsk(ID tskid);
ER ercd = iwup_tsk(ID tskid);
```

Parameters:

ID	tskid	R4	Task ID
----	-------	----	---------

Return Parameters:

ER	ercd	R0	Normal end (E_OK) or error code
----	------	----	---------------------------------

Error Codes:

E_ID	[p]	Invalid ID number (tskid < 0, tskid > CFG_MAXTSKID, or tskid = TSK_SELF(0) is specified in a non-task context)
E_NOEXS	[k]	Undefined (Task indicated by tskid does not exist)
E_OBJ	[k]	Object status is invalid (Task indicated by tskid is in the DORMANT state)
E_QOVR	[k]	Queuing overflow (wupcnt > 15)

Function:

Each service call releases a task from the WAITING state after the task was assigned to the WAITING state by calling the service call slp_tsk or tslp_tsk. If the target task did not enter the WAITING state by calling the service call slp_tsk or tslp_tsk, up to 15 requests to wake up a task can be stored.

By specifying tskid = TSK_SELF (0), the current task can be specified.

3.5.3 Cancel Wakeup Task (can_wup, ican_wup)

C-Language API:

```
ER_UINT wupcnt = can_wup(ID tskid);  
ER_UINT wupcnt = ican_wup(ID tskid);
```

Parameters:

ID	tskid	R4	Task ID
----	-------	----	---------

Return Parameters:

ER_UINT	wupcnt	R0	Number of queued task wake-up requests (0 or a positive value) or error code
---------	--------	----	------------------------------------------------------------------------------

Error Codes:

E_ID	[p]	Out of ID range (tskid < 0, tskid > CFG_MAXTSKID, or tskid = TSK_SELF(0) is specified in a non-task context)
E_NOEXS	[k]	Undefined (Task indicated by tskid is not created)
E_OBJ	[k]	Object status is invalid (Task indicated by tskid is in the DORMANT state)

Function:

Each service call calculates the number of wake-up requests queued for the task specified by tskid, then returns the result as a return parameter and invalidate all of those requests.

By specifying tskid = TSK_SELF (0), the current task can be specified.

3.5.4 Release WAITING State Forcibly (rel_wai, irel_wai)

C-Language API:

```
ER ercd = rel_wai(ID tskid);
ER ercd = irel_wai(ID tskid);
```

Parameters:

ID	tskid	R4	Task ID
----	-------	----	---------

Return Parameters:

ER_UINT	ercd	R0	Normal end (E_OK) or error code
---------	------	----	---------------------------------

Error Codes:

E_ID	[p]	Invalid ID number (tskid ≤ 0 or tskid > CFG_MAXTSKID)
E_NOEXS	[k]	Undefined (Task indicated by tskid is not created)
E_OBJ	[k]	Object status is invalid (Task indicated by tskid is in the DORMANT state or the current task is specified)

Function:

When the task specified by tskid is in some kind of WAITING state (not including a SUSPENDED state or shared-stack WAITING state), it is forcibly cancelled. E_RLWAI is returned as the error code for the task for which the WAITING state is cancelled by the service call rel_wai or irel_wai.

If the service calls rel_wai and irel_wai are called for a task in a WAITING-SUSPENDED state, the task enters the SUSPENDED state. Thereafter, if the service call rsm_tsk, irsm_tsk, frsm_tsk, or ifrsm_tsk is issued and the SUSPENDED state is cancelled, E_RLWAI is returned as the error code for the task.

To cancel the SUSPENDED state, rsm_tsk, irsm_tsk, frsm_tsk or ifrsm_tsk should be used.

Note that there is no service call to cancel shared-stack WAITING state.

3.5.5 Suspend Task (sus_tsk, isus_tsk)

C-Language API:

```
ER ercd = sus_tsk(ID tskid);  
ER ercd = isus_tsk(ID tskid);
```

Parameters:

ID	tskid	R4	Task ID
----	-------	----	---------

Return Parameters:

ER	ercd	R0	Normal end (E_OK) or error code
----	------	----	---------------------------------

Error Codes:

E_ID	[p]	Invalid ID number (tskid < 0, tskid > CFG_MAXTSKID, or tskid = TSK_SELF(0) is specified in a non-task context)
E_NOEXS	[k]	Undefined (Task indicated by tskid does not exist)
E_OBJ	[k]	Object status is invalid (Task specified by tskid is in the DORMANT state)
E_CTX	[k]	Context error (tskid=TSK_SELF(0) or the current task ID is specified in a task context while dispatch is disabled)
E_QOVR	[k]	Queuing overflow (suscnt > 15)

Function:

Each service call suspends execution of the task specified by tskid and shifts the task to the SUSPENDED state. If the specified task is in the WAITING state, the task shifts to the WAITING-SUSPENDED state.

By specifying tskid = TSK_SELF (0), the current task can be specified.

The SUSPENDED state can be cancelled by calling the service call rsm_tsk, irsm_tsk, frsm_tsk, or ifrsm_tsk.

Requests to suspend a task by calling the service calls sus_tsk and isus_tsk are nested. Up to 15 requests can be stored.

Requests to suspend a task by calling the service calls sus_tsk and isus_tsk are delayed in the following cases:

1. When the task specified by tskid masks the suspend request by calling the service call vchg_tmd, the task enters the SUSPENDED state immediately after the suspend request is cancelled by the service call vchg_tmd (by specifying tmd = 0).
2. When the task specified by tskid has called service call dis_dsp to disable task dispatch, the task enters the SUSPENDED state immediately after task execution resumes.

Delayed requests to suspend a task can be cancelled by calling service call rsm_tsk, irsm_tsk, frsm_tsk, or ifrsm_tsk. Therefore, tasks are suspended when there are one or more delayed suspend requests.

3.5.6 Resume Task Force, Task to Resume (rsm_tsk, irsm_tsk, frsm_tsk, ifrsm_tsk)

C-Language API:

```
ER ercd = rsm_tsk(ID tskid);
ER ercd = irsm_tsk(ID tskid);
ER ercd = frsm_tsk(ID tskid);
ER ercd = ifrsm_tsk(ID tskid);
```

Parameters:

ID	tskid	R4	Task ID
----	-------	----	---------

Return Parameters:

ER	ercd	R0	Normal end (E_OK) or error code
----	------	----	---------------------------------

Error Codes:

E_ID	[p]	Invalid ID number (tskid < 0 or tskid > CFG_MAXTSKID)
E_NOEXS	[k]	Undefined (Task indicated by tskid does not exist)
E_OBJ	[k]	Object status is invalid (Task indicated by tskid is not in the SUSPENDED state, task is in the DORMANT state, or the current task is specified)

Function:

Each service call releases the task specified by parameter tskid from the SUSPENDED state. Service calls rsm_tsk and irsm_tsk decrement, by one, the number of nested requests to suspend, and release the task from the SUSPENDED state when the number of the nested requests becomes 0. Service calls frsm_tsk and ifrsm_tsk modify the number of nested requests to 0, and release the task from the SUSPENDED state. When the task is in the WAITING-SUSPENDED state, the task is shifted to the WAITING state.

3.5.7 Delay Task (dly_tsk)

C-Language API:

```
ER ercd = dly_tsk(RELTIM dlytim);
```

Parameters:

RELTIM	dlytim	R4	Delayed time
--------	--------	----	--------------

Return Parameters:

ER	ercd	R0	Normal end (E_OK) or error code
----	------	----	---------------------------------

Error Codes:

E_CTX	[k]	Context error (Called from disabled system state)
E_RLWAI	[k]	WAITING state is forcibly cancelled (rel_wai service call was issued in the WAITING state)

Function:

The current task is transferred from the RUNNING state to a timed WAITING state, and waits until the time specified by dlytim has expired. When the time specified by dlytim has elapsed, the state of the current task is returned to the READY state. The current task is put into a WAITING state even if dlytim = 0 is specified.

If a value larger than 1 is specified for CFG_TICDENO (the denominator for time tick cycles), the maximum value that can be specified for dlytim is H'ffffffff/CFG_TICDENO. If a value larger than this is specified, operation is not guaranteed.

This service call differs from the service call tslp_tsk in that it terminates normally when execution is delayed by the amount of time specified by dlytim. Further, even if a service call wup_tsk or iwup_tsk is executed, the WAITING state is not cancelled. The WAITING state is cancelled before the delay time has elapsed only when a service call rel_wai, irel_wai, or ter_tsk is called.

For details on the time watch method, refer to section 2.16.4(2), Time Watch Method.

3.5.8 Set Task Event Flag (vset_tfl, ivset_tfl)

C-Language API:

```
ER ercd = vset_tfl(ID tskid, UINT setptn);
ER ercd = ivset_tfl(ID tskid, UINT setptn);
```

Parameters:

ID	tskid	R4	Task ID
UINT	setptn	R5	Bit pattern to set

Return Parameters:

ER	ercd	R0	Normal end (E_OK) or error code
----	------	----	---------------------------------

Error Codes:

E_ID	[p]	Out of ID range (tskid < 0, tskid > CFG_MAXTSKID, or tskid = TSK_SELF(0) is specified in a non-task context)
E_NOEXS	[k]	Undefined (Task indicated by tskid does not exist)
E_OBJ	[k]	Object status is invalid (Task specified by tskid is in the DORMANT state)

Function:

The task event flag of the task indicated by parameter tskid is ORed with the value indicated by the parameter setptn. Note that the lower 16 bits of the bit pattern to specify in parameter setptn must be set to 0 because the corresponding bits of the event flag are reserved for future expansion.

By specifying tskid = TSK_SELF (0), the current task can be specified.

When the logical sum of the waiting pattern and the updated pattern of the task event flag is not 0, the task is released from the WAITING state and the task event flag is cleared to 0.

The service calls vset_tfl and ivset_tfl are functions original to the HI7000/4 series.

3.5.9 Clear Task Event Flag (vclr_tfl, ivclr_tfl)

C-Language API:

```
ER ercd = vclr_tfl(ID tskid, UINT clrptn);
ER ercd = ivclr_tfl(ID tskid, UINT clrptn);
```

Parameters:

ID	tskid	R4	Task ID
UINT	clrptn	R5	Bit pattern to clear

Return Parameters:

ER	ercd	R0	Normal end (E_OK) or error code
----	------	----	---------------------------------

Error Codes:

E_ID	[p]	Out of ID range (tskid < 0, tskid > CFG_MAXTSKID, or tskid = TSK_SELF(0) is specified in a non-task context)
E_NOEXS	[p]	Undefined (Task indicated by tskid does not exist)
E_OBJ	[k]	Object status is invalid (Task specified by tskid is in the DORMANT state)

Function:

The task event flag of the task indicated by the parameter tskid are ANDed with the value indicated by parameter clrptn. Note that the lower 16 bits of the bit pattern to specify parameter clrptn must be set to H'ffff because the corresponding bits of the event flag are reserved for future expansion.

By specifying tskid = TSK_SELF (0), the current task can be specified.

The service calls vclr_tfl and ivclr_tfl are functions original to the HI7000/4 series.

3.5.10 Wait Task Event Flag (vwai_tfl, vpol_tfl, vtwai_tfl)

C-Language API:

```
ER ercd = vwai_tfl(UINT waiptn, UINT *p_tflptn);
ER ercd = vpol_tfl(UINT waiptn, UINT *p_tflptn);
ER ercd = vtwai_tfl(UINT waiptn, UINT *p_tflptn, TMO tmout);
```

Parameters:

UINT	waiptn	R4	Bit pattern to wait
UINT	*p_tflptn	R5	Pointer to the area where the bit pattern when releasing the WAITING state is to be returned
 <vtwai_tfl>			
TMO	tmout	R6	Timeout specification

Return Parameters:

ER	ercd	R0	Normal end (E_OK) or error code
UINT	*p_tflptn	R5	Pointer to the area where the bit pattern when releasing the WAITING state is stored

Error Codes:

E_PAR	[p]	Parameter error (p_tflptn is other than a multiple of four, waiptn = 0, or tmout ≤ -2)
E_CTX	[k]	Context error (Called from disabled system state)
E_TMOUT	[k]	Timeout
E_RLWAI	[k]	WAITING state is forcibly cancelled (rel_wai service call was called in the WAITING state)

Function:

Each service call waits for any bit of the task event flag specified by waiptn to be set. When the wait release condition is satisfied, the bit pattern of the task event flag is returned to the area indicated by parameter p_tflptn. At the same time, the task event flag value is cleared to 0.

Each service call immediately terminates if any bit specified by waiptn is already set when a service call is called. If no bit is set, the task that called service calls vwai_tfl or vtwai_tfl enters the WAITING state. With service call vpol_tfl, error code E_TMOUT is immediately returned in this case. Tasks are released from the WAITING state when any bits specified by waiptn are set by the service call vset_tfl.

The task event flag value is 0 at task initiation.

In service call vtwai_tfl, the parameter tmout specifies the timeout period.

Section3 Service Calls

If a positive value is specified for the parameter `tmout`, error code `E_TMOU`T is returned when `tmout` time has passed without the wait release condition being satisfied. If `tmout = TMO_POL` (0) is specified, the same operation as for the service call `vpol_tfl` will be performed. If `tmout = TMO_FEVR` (-1) is specified, the timeout monitoring is not performed. In other words, the same operation as for the service call `vwai_tfl` will be performed.

If a value larger than 1 is specified for `CFG_TICDENO` (the denominator for time tick cycles), the maximum value that can be specified for `tmout` is `H'7ffffff/CFG_TICDENO`. If a value larger than this is specified, operation is not guaranteed.

For details on the time watch method, refer to section 2.16.4(2), Time Watch Method.

The service calls `vwai_tfl`, `vpol_tfl`, and `vtwai_tfl` are functions original to the HI7000/4 series.

3.6 Task Exception Processing Functions

Task Exception Processing Service Calls: Task exception processing is controlled by the service calls listed in table 3.18.

Table 3.18 Service Calls for Task Exception Processing

Service Call ¹	Description	System State ²
		T/N/E/D/U/L/C
def_tex [s]	Defines the task exception processing routine	T/E/D/U
idef_tex		N/E/D/U
ras_tex [S]	Requests the task exception processing	T/E/D/U/C
iras_tex [S]		N/E/D/U/C
dis_tex [S]	Disables the task exception processing	T/E/D/U
ena_tex [S]	Enables the task exception processing	T/E/D/U
sns_tex [S]	Refers to the task exception processing disabled state	T/N/E/D/U/L/C
ref_tex	Refers to the task exception processing state	T/E/D/U
iref_tex		N/E/D/U

- Notes: 1. [S]: Standard profile service calls
[s]: Service calls that are not standard profile service calls but are needed in order to use the standard profile function
2. T: Can be called from task context
N: Can be called from non-task context
E: Can be called from dispatch-enabled state
D: Can be called from dispatch-disabled state
U: Can be called from CPU-unlocked state
L: Can be called from CPU-locked state
C: Can be called from CPU exception handler

Task Exception Specifications: The task exception specifications are listed in table 3.19.

Table 3.19 Task Exception Specifications

Item	Description
Exception factor	32 bits
Status at task initiation	<ul style="list-style-type: none">• Task exception processing disabled state• No pended exception factors
Attribute supported	TA_HLNG: The task is written in a high-level language TA_ASM: The task is written in assembly language [HI7000/4, HI7700/4] TA_COP0: The task uses the DSP [HI7000/4] TA_COP1: The task uses the FPU [HI7750/4] TA_COP1: The task uses bank 0 in the FPU TA_COP2: The task uses bank 1 in the FPU

The task exception routine is initiated as the task context when the following conditions are satisfied.

- Task exception processing enabled state
- Pended exception factor is not 0
- Task is in the RUNNING state
- Non-task context or the CPU exception handler is not executed

When the task returns from the task exception processing routine, the processing that is performed before the task exception processing routine was initiated is continued. At this time, the task enters the task exception enabled state. When the pended exception factor is not 0, the task exception processing routine is initiated again.

3.6.1 Define Task Exception Processing Routine (def_tex, ideof_tex)

C-Language API:

```
ER ercd = def_tex(ID tskid, T_DTEX *pk_dtex);
ER ercd = ideof_tex(ID tskid, T_DTEX *pk_dtex);
```

Parameters:

ID	tskid	R4	Task ID
T_DTEX	*pk_dtex	R5	Pointer to the packet where task exception-processing-routine definition information is stored

Return Parameters:

ER	ercd	R0	Normal end (E_OK) or error code
----	------	----	---------------------------------

Packet Structure

```
typedef struct t_dtex{
    ATR    texatr;    0    4    Task exception processing routine
                                attribute
    FP    texrtn;    +4    4    Task exception processing routine
                                initiation address
}T_DTEX;
```

Error Codes:

E_RSATR	[p]	Reserved attribute (texatr is invalid)
E_PAR	[p]	Parameter error (pk_dtex is other than a multiple of four or texrtn is an odd value)
E_ID	[p]	Out of ID range (tskid < 0, tskid > CFG_MAXTSKID, or tskid = TSK_SELF(0) is specified in a non-task context)
E_NOEXS	[k]	Undefined (Task indicated by tskid does not exist)

Function:

The task exception processing routine indicated by tskid is defined as specified by pk_dtex.

By specifying tskid = TSK_SELF(0), the current task can be specified.

The parameter texatr is specified in the following format. See table 3.20 for details.

```
texatr := ((TA_HLNG || TA_ASM) [[TA_COP0] [[TA_COP1] [[TA_COP2])
```

Table 3.20 Task Exception Routine Attribute (texatr)

texatr	Code	Description
TA_HLNG	H'00000000	The task is written in a high-level language
TA_ASM	H'00000001	The task is written in assembly language
TA_COP0	H'00000100	The task uses the DSP (HI7000/4, HI7700/4)
TA_COP1	H'00000200	Uses the FPU (HI7000/4) Uses bank 0 in the FPU (HI7750/4) *
TA_COP2	H'00000400	Uses bank 1 in the FPU (HI7750/4). *

Note The initial value of the FPSCR register is H'00040001 (bank 0).

Through specification of a TA_COPn attribute, the relevant coprocessor registers are also saved as the context of the task exception processing routine. Note that the TA_COPn attribute is not in the μ ITRON4.0 specifications.

texrtn specifies the start address of the task exception processing routine. When, in a service call def_tex or idef_tex, pk_dtex = NULL(0) is specified, the definition of the task exception processing routine for tskid is cancelled. At this time the task pended exception factor is cleared to 0, and the task is transferred to the task exception processing disabled state.

If a task exception processing routine has already been defined, the previous definition is cancelled and is replaced with the new definition. At this time, pended exception factors are not cleared and task exception processing is not disabled.

3.6.2 Request Task Exception Processing (ras_tex, iras_tex)

C-Language API:

```
ER ercd = ras_tex(ID tskid, TEXPTN rasptn);
ER ercd = iras_tex(ID tskid, TEXPTN rasptn);
```

Parameters:

ID	tskid	R4	Task ID
TEXPTN	rasptn	R5	Task exception factor of task exception processing to be requested

Return Parameters:

ER	ercd	R0	Normal end (E_OK) or error code
----	------	----	---------------------------------

Error Codes:

E_PAR	[p]	Parameter error (rasptn = 0)
E_ID	[p]	Out of ID range (tskid < 0, tskid > CFG_MAXTSKID, or tskid = TSK_SELF(0) is specified in a non-task context)
E_NOEXS	[k]	Undefined (Task indicated by tskid does not exist)
E_OBJ	[k]	Object status is invalid (Task indicated by tskid is in the DORMANT state or task exception processing routine is not defined)

Function:

Requests task exception processing by the task exception factor specified by rasptn, for the task specified by tskid. That is, the pending exception factor for the task is ORed with the value indicated by the parameter rasptn.

By specifying tskid = TSK_SELF(0), the current task can be specified.

When the conditions for starting task exception processing routine are satisfied, the task exception processing routine is initiated.

The service calls can also be called from the CPU exception handler.

3.6.3 Disable Task Exception Processing (dis_tex)

C-Language API:

```
ER ercd = dis_tex(void);
```

Parameters:

None

Return Parameters:

ER ercd R0 Normal end (E_OK) or error code

Error Codes:

E_OBJ	[k]	Object status is invalid (Task exception processing routine is not defined on the current task)
E_CTX	[k]	Context error (Called from disabled system state)

Function:

The current task is transferred to the task exception processing disabled state.

3.6.4 Enable Task Exception Processing (ena_tex)

C-Language API:

```
ER ercd = ena_tex(void);
```

Parameters:

None

Return Parameters:

ER ercd R0 Normal end (E_OK) or error code

Error Codes:

E_OBJ	[k]	Object status is invalid (Task exception processing routine is not defined on the current task)
E_CTX	[k]	Context error (Called from disabled system state)

Function:

The current task is transferred to the task exception enabled state.

When conditions for starting the task exception processing routine are satisfied through this service call, the task exception processing routine is initiated.

3.6.5 Refer To Task Exception Processing Disabled State (sns_tex)

C-Language API:

```
BOOL state= sns_tex(void);
```

Parameters:

None

Return Parameters:

BOOL state R0 Task exception processing disabled state

Error Codes:

None

Function:

When a task in the RUNNING state is in the task exception processing disabled state, TRUE is returned; when in the task exception processing enabled state, FALSE is returned. A task in the RUNNING state is the current task when called from the task context, and when called from a non-task context is the task which had been run immediately prior to the transition to the non-task context. When a task is called from a non-task context, and no task is in the RUNNING state, TRUE is returned.

Tasks for which no task exception processing routines are defined are held in the task exception processing disabled state, so that when no task exception processing routine has been defined for a task in the RUNNING state, this service call returns TRUE.

This service call can also be called in the CPU-locked state and from the CPU exception handler.

3.6.6 Refer to Task Exception Processing State (ref_tex, iref_tex)

C-Language API:

```
ER ercd = ref_tex(ID tskid, T_RTEX *pk_rtex);
ER ercd = iref_tex(ID tskid, T_RTEX *pk_rtex);
```

Parameters:

ID	tskid	R4	Task ID
T_RTEX	*pk_rtex	R5	Pointer to the packet where the task exception processing state is to be returned

Return Parameters:

ER	ercd	R0	Normal end (E_OK) or error code
T_RTEX	*pk_rtex	R5	Pointer to the packet where the task exception processing state is stored

Packet Structure:

```
typedef struct t_rtex{
    STAT  textstat;  0   4   Task exception processing state
    TEXPTN pndptn;  +4  4   Pended exception factor
}T_RTEX;
```

Error Codes:

E_PAR	[p]	Parameter error (pk_rtex is other than a multiple of four)
E_ID	[p]	Out of ID range (tskid < 0, tskid > CFG_MAXTSKID, or tskid = TSK_SELF(0) is specified in a non-task context)
E_NOEXS	[k]	Undefined (Task indicated by tskid does not exist)
E_OBJ	[k]	Object status is invalid (Task indicated by tskid is in the DORMANT state or task exception processing routine is not defined)

Function:

The state relating to task exception processing for the task specified by tskid is referenced, and the result is returned to the area indicated by pk_rtex.

One of the following values is returned for textstat, according to whether the target task is in a task exception enabled state or a task exception processing disabled state.

Table 3.21 Task Exception Processing State (textstat)

textstat	Code	Description
TTEX_ENA	H'00000000	Task exception processing enabled state
TTEX_DIS	H'00000001	Task exception processing disabled state

The pended exception factor for the target task is returned as pndptn. If there are no unprocessed exception processing requests, 0 is returned as pndptn.

By specifying tskid = TSK_SELF(0), the current task can be specified.

3.7 Synchronization and Communication (Semaphore)

Semaphore Service Calls: Semaphores are controlled by the service calls listed in table 3.22.

Table 3.22 Service Calls for Event Flag Control

Service Call ¹	Description	System State ²
		T/N/E/D/U/L/C
cre_sem [s]	Creates semaphore	T/E/D/U
icre_sem		N/E/D/U
acre_sem	Creates semaphore and assigns semaphore ID automatically	T/E/D/U
iacre_sem		N/E/D/U
del_sem	Deletes semaphore	T/E/D/U
sig_sem [S]	Returns semaphore resource	T/E/D/U
isig_sem [S]		N/E/D/U
wai_sem [S]	Waits on semaphore resource	T/E/U
pol_sem [S]	Polls and waits on semaphore resource	T/E/D/U
ipol_sem		N/E/D/U
twai_sem [S]	Waits on semaphore resource with timeout function	T/E/U
ref_sem	Refers to semaphore state	T/E/D/U
iref_sem		N/E/D/U

Notes: 1. [S]: Standard profile service calls
 [s]: Service calls that are not standard profile service calls but are needed in order to use the standard profile function

2. T: Can be called from task context
 N: Can be called from non-task context
 E: Can be called from dispatch-enabled state
 D: Can be called from dispatch-disabled state
 U: Can be called from CPU-unlocked state
 L: Can be called from CPU-locked state
 C: Can be called from CPU exception handler

Semaphore Specifications: The semaphore specifications are listed in table 3.23.

Table 3.23 Semaphore Specifications

Item	Description
Semaphore ID	1 to CFG_MAXSEMID (1023 max.)
Maximum semaphore count	65535
Attribute supported	TA_TFIFO: Task wait queue is managed on a FIFO basis TA_TPRI: Task wait queue is managed on priority

3.7.1 Create Semaphore**(cre_sem, icre_sem,)****(acre_sem, iacre_sem: Assign Semaphore ID Automatically)****C-Language API:**

```

ER ercd = cre_sem(ID semid, T_CSEM *pk_csem);
ER ercd = icre_sem(ID semid, T_CSEM *pk_csem);
ER_ID semid = acre_sem(T_CSEM *pk_csem);
ER_ID semid = iacre_sem(T_CSEM *pk_csem);

```

Parameters:

```

<cre_sem, icre_sem>
ID          semid      R4  Semaphore ID
T_CSEM      *pk_csem  R5  Pointer to the packet where semaphore
                           creation information is stored

<acre_sem, iacre_sem>
T_CSEM      *pk_csem  R4  Pointer to the packet where semaphore
                           creation information is stored

```

Return Parameters:

```

<cre_sem, icre_sem>
ER          ercd      R0  Normal end (E_OK) or error code

<acre_sem, iacre_sem>
ER_ID      semid     R0  ID of created semaphore (a positive
                           value) or error code

```

Packet Structure

```

typedef struct t_csem{
    ATR      sematr;   +0 4  Semaphore attribute
    UINT     isemcnt  +4 4  Initial value of semaphore resource count
    UINT     maxsem;  +8 4  Maximum number of semaphore resources
}T_CSEM;

```

Error Codes:

```

E_RSATR [p] Invalid attribute (sematr is invalid)
E_PAR   [p] Parameter error (pk_csem is other than a multiple of four,
                           maxsem = 0, maxsem > H'ffff, or isemcnt > maxsem)
E_ID    [p] Invalid ID number (semid ≤ 0 or semid > CFG_MAXSEMID)
E_OBJ   [k] Object status is invalid
                           (Semaphore indicated by semid already exists)
E_NOID  [k] No ID available

```

Function:

Service calls `cre_sem` and `icre_sem` create a semaphore with an ID indicated by `semid` using the contents specified by the parameter `pk_csem`.

The service calls `acre_sem` and `iacre_sem` search for an unused semaphore ID, create a semaphore that has this ID with the contents specified by the parameter `pk_csem`, and return the ID as a return parameter. The range for searching for an unused semaphore ID is 1 to `CFG_MAXSEMID`.

The parameter `sematr` is specified in the following format. See table 3.24 for details.

`sematr: = (TA_TFIFO || TA_TPRI)`

Table 3.24 Event Attributes (`sematr`)

sematr	Code	Description
TA_TFIFO	H'00000000	Task wait queue is managed on a FIFO basis
TA_TPRI	H'00000001	Task wait queue is managed on priority

The parameter `isemcnt` specifies the initial value of the semaphore to be created. It can range from 0 to `maxsem`.

The parameter `maxsem` specifies the maximum number of resources of the semaphore to be created. It can range from 1 to 65535.

A semaphore can also be created statically by the configurator.

3.7.2 Delete Semaphore (del_sem)

C-Language API:

```
ER ercd = del_sem(ID semid);
```

Parameters:

ID	semid	R4	Semaphore ID
----	-------	----	--------------

Return Parameters:

ER	ercd	R0	Normal end (E_OK) or error code
----	------	----	---------------------------------

Error Codes:

E_ID	[p]	Invalid ID number (semid ≤ 0 or semid > CFG_MAXSEMID)
E_NOEXS	[k]	Undefined (Semaphore indicated by semid does not exist)
E_CTX	[k]	Context error (Called from disabled system state)

Function:

The service call del_sem deletes the semaphore indicated by the parameter semid.

No error will occur even if there is a task waiting to acquire a resource with the semaphore indicated by semid. However, in that case, the task in the WAITING state will be released and error code E_DLT will be returned.

3.7.3 Returns Semaphore Resource (sig_sem, isig_sem)

C-Language API:

```
ER ercd = sig_sem(ID semid);  
ER ercd = isig_sem(ID semid);
```

Parameters:

ID	semid	R4	Semaphore ID
----	-------	----	--------------

Return Parameters:

ER	ercd	R0	Normal end (E_OK) or error code
----	------	----	---------------------------------

Error Codes:

E_ID	[p]	Invalid ID number (semid ≤ 0 or semid > CFG_MAXSEMID)
E_NOEXS	[k]	Undefined (Semaphore indicated by semid does not exist)
E_QOVR	[k]	Queuing overflow (semcnt > maxsem')

Note: maxsem: Maximum number of semaphore resources specified at semaphore creation

Function:

Each service call returns one resource to the semaphore indicated by semid. If there is a task waiting for the semaphore indicated by semid, the task at the head of the wait queue is released from the WAITING state, and the resource is assigned to the task. If there are no tasks in the wait queue, the semaphore count is incremented by one.

The maximum semaphore count is maxsem, which is specified at semaphore creation.

3.7.4 Wait on Semaphore (wai_sem, pol_sem, ipol_sem, twai_sem)

C-Language API:

```
ER ercd = wai_sem(ID semid);
ER ercd = pol_sem(ID semid);
ER ercd = ipol_sem(ID semid);
ER ercd = twai_sem(ID semid, TMO tmout);
```

Parameters:

ID	semid	R4	Semaphore ID
<twai_sem>			
TMO	tmout	R5	Timeout specification

Return Parameters:

ER	ercd	R0	Normal end (E_OK) or error code
----	------	----	---------------------------------

Error Codes:

E_PAR	[p]	Parameter error (tmout ≤ -2)
E_ID	[p]	Invalid ID number (semid ≤ 0 or semid > CFG_MAXSEMID)
E_NOEXS	[k]	Undefined (Semaphore indicated by semid does not exist)
E_CTX	[k]	Context error (Called from disabled system state)
E_DLT	[k]	Waiting object deleted (Target semaphore indicated by semid has been deleted while waiting)
E_RLWAI	[k]	WAITING state is forcibly cancelled (rel_wai service call was called in the WAITING state)
E_TMOUT	[k]	Polling failed or timeout

Function:

Each service call acquires one resource from the semaphore specified by semid.

Each service call decrements the number of resources of the target semaphore by one if the number of resources of the target semaphore is equal to or greater than 1, and the task calling the service call continues execution. If no resources exist, the task calling the service call wai_sem or twai_sem shifts to the WAITING state, and with service call pol_sem or ipol_sem, error code E_TMOUT is immediately returned. The wait queue is managed according to the attribute specified at creation.

The parameter tmout specified by service call twai_sem specifies the timeout period. If a positive value is specified for the parameter tmout, error code E_TMOUT is returned when the tmout period has passed without the wait release conditions being satisfied.

If tmout = TMO_POL (0) is specified, the same operation as for the service call pol_sem will be performed.

If tmout = TMO_FEVR (-1) is specified, the timeout monitoring is not performed. In this case, the same operation as for the service call wai_sem will be performed.

Section3 Service Calls

If a value larger than 1 is specified for CFG_TICDENO (the denominator for time tick cycles), the maximum value that can be specified for tmout is $H'7ffffff/CFG_TICDENO$. If a value larger than this is specified, operation is not guaranteed.

For detail of time watch method, refer to section 2.16.4(2), Time Watch Method.

3.7.5 Refer to Semaphore State (ref_sem, iref_sem)

C-Language API:

```
ER ercd = ref_sem(ID semid, T_RSEM *pk_rsem);
ER ercd = iref_sem(ID semid, T_RSEM *pk_rsem);
```

Parameters:

ID	semid	R4	Semaphore ID
T_RSEM	*pk_rsem	R5	Pointer to the area where the semaphore state is to be returned

Return Parameters:

ER	ercd	R0	Normal end (E_OK) or error code
T_RSEM	*pk_rsem	R5	Pointer to the area where the semaphore state is stored

Packet Structure:

```
typedef struct t_rsem{
    ID      wtskid;  +0  2  Wait task ID
    UINT    semcnt; +4  4  Current semaphore count value
}T_RSEM;
```

Error Codes:

E_PAR	[p]	Parameter error (pk_rsem is other than a multiple of four)
E_ID	[p]	Invalid ID number (semid ≤ 0 or semid > CFG_MAXSEMID)
E_NOEXS	[k]	Undefined (Semaphore indicated by semid does not exist)

Function:

Each service call refers to the state of the semaphore indicated by the parameter semid. Each service call returns the task ID at the head of the semaphore wait queue (wtskid) and the current semaphore count (semcnt), to the area specified by the parameter pk_rsem. If there is no task waiting for a semaphore, TSK_NONE (0) is returned as a wait task ID.

3.8 Synchronization and Communication (Event Flag)

Event Flag Service Calls: Event flags are controlled by the service calls listed in table 3.25.

Table 3.25 Service Calls for Event Flag Control

Service Call ¹	Description	System State ²
		T/E/D/U/L/C
cre_flg [s]	Creates event flag	T/E/D/U
icre_flg		N/E/D/U
acre_flg	Creates event flag and assigns event flag ID automatically	T/E/D/U
iacre_flg		N/E/D/U
del_flg	Deletes event flag	T/E/D/U
set_flg [S]	Sets event flag	T/E/D/U
iset_flg [S]		N/E/D/U
clr_flg [S]	Clears event flag	T/E/D/U
iclr_flg		N/E/D/U
wai_flg [S]	Waits for event flag	T/E/U
pol_flg [S]	Polls and waits for event flag	T/E/D/U
ipol_flg [S]		N/E/D/U
twai_flg [S]	Waits for event flag with timeout function	T/E/U
ref_flg	Refers to event flag state	T/E/D/U
iref_flg		N/E/D/U

- Notes: 1. [S]: Standard profile service calls
 [s]: Service calls that are not standard profile service calls but are needed in order to use the standard profile function
2. T: Can be called from task context
 N: Can be called from non-task context
 E: Can be called from dispatch-enabled state
 D: Can be called from dispatch-disabled state
 U: Can be called from CPU-unlocked state
 L: Can be called from CPU-locked state
 C: Can be called from CPU exception handler

Event Flag Specifications: The event flag specifications are listed in table 3.26.

Table 3.26 Event Flag Specifications

Item	Description
Event flag ID	1 to CFG_MAXFLGID (1023 max.)
Maximum flag pattern size	32 bits
Attribute supported	TA_TFIFO: Task wait queue is managed on a FIFO basis TA_TPRI: Task wait queue is managed on priority TA_WSGL: Does not permit multiple tasks to wait for the event flag TA_WMUL: Permits multiple tasks to wait for the event flag TA_CLR: An event flag is cleared at the time of waiting release

3.8.1 Create Event Flag

(cre_flg, icre_flg)

(acre_flg, iacre_flg: Assign Event Flag ID Automatically)

C-Language API:

```
ER ercd = cre_flg(ID flgid, T_CFLG *pk_cflg);
ER ercd = icre_flg(ID flgid, T_CFLG *pk_cflg);
ER_ID flgid = acre_flg(T_CFLG *pk_cflg);
ER_ID flgid = iacre_flg(T_CFLG *pk_cflg);
```

Parameters:

```
<cre_flg, icre_flg>
ID          flgid      R4    Event flag ID
T_CFLG     *pk_cflg   R5    Pointer to the packet where the event flag
      creation information is stored

<acre_flg, iacre_flg>
T_CFLG     *pk_cflg   R4    Pointer to the packet where the event flag
      creation information is stored
```

Return Parameters:

```
<cre_flg, icre_flg>
ER          ercd       R0    Normal end (E_OK) or error code

<acre_flg, iacre_flg>
ER_ID      flgid      R0    Created event flag ID (a positive value) or
      error code
```

Packet Structure:

```
typedef struct t_cflg{
    ATR      flgatr;   +0   4   Event flag attribute
    FLGPTN   iflgptn; +4   4   Initial value of event flag
}T_CFLG;
```

Error Codes:

E_RSATR	[p]	Invalid attribute (flgatr is invalid)
E_PAR	[p]	Parameter error (pk_cflg is other than a multiple of four)
E_ID	[p]	Invalid ID number (flgid ≤ 0 or flgid > CFG_MAXFLGID)
E_OBJ	[k]	Object status is invalid (Event flag indicated by flgid already exists)
E_NOID	[k]	No ID available

Function:

The service calls `cre_flg` and `icre_flg` create an event flag with an ID indicated by `flgid` with the contents indicated by `pk_cflg`.

The service calls `acre_flg` and `iacre_flg` search for an unused event flag ID and create an event flag that has this ID, with the contents specified by the parameter `pk_cflg`. The created event flag ID is returned as a return parameter. The range for searching for an unused event flag ID is 1 to `CFG_MAXFLGID`.

The parameter `flgatr` is specified in the following format. See table 3.27 for details.

$$\text{flgatr} := ((\text{TA_TFIFO} \parallel \text{TA_TPRI}) \mid (\text{TA_WSGL} \parallel \text{TA_WMUL})) \mid [\text{TA_CLR}]$$
Table 3.27 Event Flag Attribute (flgatr)

flgatr	Code	Description
TA_TFIFO	H'00000000	Task wait queue is managed on a FIFO basis
TA_TPRI	H'00000001	Task wait queue is managed on priority
TA_WSGL	H'00000000	Does not permit multiple tasks to wait for the event flag
TA_WMUL	H'00000002	Permits multiple tasks to wait for the event flag
TA_CLR	H'00000004	Clears event flag at the time of waiting release

If `TA_WSGL` attribute is specified for `flgatr`, only one task can wait for the created event flag. In this case, the event flag performs the same operation when either attribute `TA_TFIFO` or `TA_TPRI` is specified. On the other hand, multiple tasks can enter the `WAITING` state when the `TA_WMUL` attribute is specified. If `TA_CLR` attribute is specified for `flgatr`, all bits of the event flag bit pattern are cleared when the wait release condition is satisfied.

The parameter `iflgptn` specifies the initial value of the event flag.

An event flag can also be created statically by the configurator.

3.8.2 Delete Event Flag (del_flg)

C-Language API:

```
ER ercd = del_flg(ID flgid);
```

Parameters:

ID	flgid	R4	Event flag ID
----	-------	----	---------------

Return Parameters:

ER	ercd	R0	Normal end (E_OK) or error code
----	------	----	---------------------------------

Error Codes:

E_ID	[p]	Invalid ID number (flgid ≤ 0 or flgid > CFG_MAXFLGID)
E_NOEXS	[k]	Undefined (Event flag indicated by flgid does not exist)
E_CTX	[k]	Context error (Called from disabled system state)

Function:

The service call del_flg deletes the event flag indicated by the parameter flgid.

No error will occur even if there is a task waiting for the conditions to be met in the event flag indicated by flgid. However, in that case, the task in the WAITING state will be released and error code E_DLT will be returned.

3.8.3 Set Event Flag (set_flg, iset_flg)

C-Language API:

```
ER ercd = set_flg(ID flgid, FLGPTN setptn);
ER ercd = iset_flg(ID flgid, FLGPTN setptn);
```

Parameters:

ID	flgid	R4	Event flag ID
FLGPTN	setptn	R5	Bit pattern to set

Return Parameters:

ER	ercd	R0	Normal end (E_OK) or error code
----	------	----	---------------------------------

Error Codes:

E_ID	[p]	Invalid ID number (flgid ≤ 0 or flgid > CFG_MAXFLGID)
E_NOEXS	[k]	Undefined (Event flag indicated by flgid does not exist)

Function:

The event flag specified by flgid is ORed with the value indicated by the parameter setptn.

Each service call shifts a task to the READY state after the event flag value has been changed and when the wait release conditions of a task waiting for an event flag have been satisfied. Wait release conditions are checked in the queue order. All bits of the event flag bit pattern and service call are cleared when the TA_CLR attribute is set to the target event flag attribute.

When the TA_WMUL attribute is set to the event flag and the TA_CLR attribute is not specified, multiple wait tasks may be released when the service call set_flg is called only once. When multiple wait tasks are released, the tasks are released in the queue order of the event flag.

3.8.4 Clear Event Flag (clr_flg, iclr_flg)

C-Language API:

```
ER ercd = clr_flg(ID flgid, FLGPTN clrptn);  
ER ercd = iclr_flg(ID flgid, FLGPTN clrptn);
```

Parameters:

ID	flgid	R4	Event flag ID
FLGPTN	clrptn	R5	Bit pattern to clear

Return Parameters:

ER	ercd	R0	Normal end (E_OK) or error code
----	------	----	---------------------------------

Error Codes:

E_ID	[p]	Invalid ID number (flgid ≤ 0 or flgid > CFG_MAXFLGID)
E_NOEXS	[k]	Undefined (Event flag indicated by flgid does not exist)

Function:

The event-flag bits specified by flgid is ANDed with the value indicated by the parameter clrptn.

3.8.5 Wait for Event Flag Setting (wai_flg, pol_flg, ipol_flg, twai_flg)

C-Language API:

```
ER ercd = wai_flg(ID flgid , FLGPTN waiptn, MODE wfmode, FLGPTN *p_flgptn);
ER ercd = pol_flg(ID flgid , FLGPTN waiptn, MODE wfmode, FLGPTN *p_flgptn);
ER ercd = ipol_flg(ID flgid , FLGPTN waiptn, MODE wfmode, FLGPTN *p_flgptn);
ER ercd = twai_flg (ID flgid , FLGPTN waiptn, MODE wfmode, FLGPTN *p_flgptn,
TMO tmout);
```

Parameters:

ID	flgid	R4	Event flag ID
FLGPTN	waiptn	R5	Wait bit pattern
MODE	wfmode	R6	Wait mode
FLGPTN	*p_flgptn	R7	Pointer to the area where the bit pattern at waiting release is to be returned

<twai_flg>

TMO	tmout	@R15	Timeout value
-----	-------	------	---------------

Return Parameters:

ER	ercd	R0	Normal end (E_OK) or error code
FLGPTN	*p_flgptn	R7	Pointer to the area where the bit pattern at waiting release is stored

Error Codes:

E_PAR	[p]	Parameter error (p_flgptn is other than a multiple of four, waiptn = 0, wfmode is invalid, or tmout ≤ -2)
E_ID	[p]	Invalid ID (flgid ≤ 0, flgid > CFG_MAXFLGID)
E_NOEXS	[k]	Undefined (Event flag indicated by flgid does not exist)
E_ILUSE	[k]	Illegal use of service call (A task is already waiting for the event flag with TA_WSGL attribute)
E_CTX	[k]	Context error (Called from disabled system state)
E_DLT	[k]	Waiting object deleted (Event flag indicated by flgid has been deleted in the WAITING state)
E_TMOUT	[k]	Polling failed or timeout
E_RLWAI	[k]	WAITING state was forcibly cancelled (rel_wai service call was called in the WAITING state)

Function:

A task that has called one of these service calls waits until the event flag specified by the parameter `flgid` is set according to the waiting conditions indicated by the parameters `waitpn` and `wfmode`. Each service call returns the bit pattern of the event flag to the area indicated by `p_flgptn` when the wait release condition is satisfied.

If the attribute of the target event flag is `TA_WSGL` and another task is waiting for the event flag, error code `E_ILUSE` is returned.

If the wait release conditions are met before a task calls service call `wai_flg`, `pol_flg`, `ipol_flg`, or `twai_flg`, the service call will be completed immediately. If they are not met, the task will be sent to the wait queue when the service call `wai_flg` or `twai_flg` is called. With service call `pol_flg` or `ipol_flg`, error code `E_TMOUT` is immediately returned, then the task terminates.

The parameter `wfmode` is specified in the following format. See table 3.28 for details.

`wfmode:= ((TWF_ANDW || TWF_ORW))`

Table 3.28 Wait Modes (wfmode)

wfmode	Code	Description
<code>TWF_ANDW</code>	<code>H'00000000</code>	AND wait
<code>TWF_ORW</code>	<code>H'00000001</code>	OR wait

If `TWF_ANDW` is specified as `wfmode`, the task waits until all the bits specified by `waitpn` have been set. If `TWF_ORW` is specified as `wfmode`, the task waits until any one of the bits specified by `waitpn` has been set in the specified event flag.

The parameter `tmout` specified by service call `twai_flg` specifies the timeout period. If a positive value is specified for the parameter `tmout`, error code `E_TMOUT` is returned when the timeout period has passed without the waiting release conditions being satisfied.

If `tmout = TMO_POL (0)` is specified, the same operation as for the service call `pol_flg` will be performed.

If `tmout = TMO_FEVR (-1)` is specified, the timeout monitoring is not performed. In this case, the same operation as for service call `wai_flg` will be performed.

If a value larger than 1 is specified for `CFG_TICDENO` (the denominator for time tick cycles), the maximum value that can be specified for `tmout` is `H'7fffffff/CFG_TICDENO`. If a value larger than this is specified, operation is not guaranteed.

For detail of time watch method, refer to section 2.16.4(2), Time Watch Method.

3.8.6 Refer to Event Flag State (ref_flg, iref_flg)

C-Language API

```
ER ercd = ref_flg(ID flgid , T_RFLG *pk_rflg);
ER ercd = iref_flg(ID flgid , T_RFLG *pk_rflg);
```

Parameters:

ID	flgid	R4	Event flag ID
T_RFLG	*pk_rflg	R5	Pointer to the area where the event flag state is to be returned

Return Parameters:

ER	ercd	R0	Normal end (E_OK) or error code
T_RFLG	*pk_rflg	R5	Pointer to the packet where event flag state is stored

Packet Structure:

```
typedef struct t_rflg{
    ID      wtskid;    +0  2    Wait task ID
    FLGPTN  flgptn;   +4  4    Event flag bit pattern
}T_RFLG;
```

Error Codes:

E_PAR	[p]	Parameter error (pk_rflg is other than a multiple of four)
E_ID	[p]	Invalid ID number (flgid ≤ 0 or flgid > CFG_MAXFLGID)
E_NOEXS	[k]	Undefined (Event flag indicated by flgid does not exist)

Function:

Each service call refers to the state of the event flag indicated by the parameter flgid.

Each service call returns the task ID at the head of the event flag wait queue (wtskid) and the current event flag bit pattern (flgptn), to the area specified by the parameter pk_rflg.

If there is no task waiting for the specified event flag, TSK_NONE (0) is returned as a wait task ID.

3.9 Synchronization and Communication (Data Queue)

Data Queue Service Calls: Data queues are controlled by the service calls listed in table 3.29.

Table 3.29 Service Calls for Data Queue Control

Service Call ¹	Description	System State ²
		T/E/D/U/L/C
cre_dtq [s]	Creates data queue	T/E/D/U
icre_dtq		N/E/D/U
acre_dtq	Creates data queue and assigns data queue ID automatically	T/E/D/U
iacre_dtq		N/E/D/U
del_dtq	Deletes data queue	T/E/D/U
snd_dtq [S]	Sends data to data queue	T/E/U
psnd_dtq [S]	Polls and sends data to data queue	T/E/D/U
ipsnd_dtq [S]		N/E/D/U
tsnd_dtq [S]	Sends data to data queue with timeout function	T/E/U
fsnd_dtq [S]	Forcibly sends data to data queue	T/E/D/U
ifsnd_dtq [S]		N/E/D/U
rcv_dtq [S]	Receives data from data queue	T/E/U
prcv_dtq [S]	Polls and receives data from data queue	T/E/D/U
trcv_dtq [S]	Receives data from data queue with timeout function	T/E/U
ref_dtq	Refers to data queue state	T/E/D/U
iref_dtq		N/E/D/U

Notes: 1. [S]: Standard profile service calls

[s]: Service calls that are not standard profile service calls but are needed in order to use the standard profile function

2. T: Can be called from task context

N: Can be called from non-task context

E: Can be called from dispatch-enabled state

D: Can be called from dispatch-disabled state

U: Can be called from CPU-unlocked state

L: Can be called from CPU-locked state

C: Can be called from CPU exception handler

Data Queue Specifications: The data queue specifications are listed in table 3.30.

Table 3.30 Data Queue Specifications

Item	Description
Data queue ID	1 to CFG_MAXDTQID (1023 max.)
One word	32 bits
Attribute supported	TA_TFIFO: Task queue waiting for sending a message is managed on a FIFO basis TA_TPRI: Task queue waiting for sending a message is managed on priority

3.9.1 Create Data Queue

(cre_dtq, icre_dtq,)

(acre_dtq, iacre_dtq: Assign Data Queue ID Automatically)

C-Language API:

```
ER ercd = cre_dtq(ID dtqid, T_CDTQ *pk_cdtq);
ER ercd = icre_dtq (ID dtqid, T_CDTQ *pk_cdtq);
ER_ID dtqid = acre_dtq (T_CDTQ *pk_cdtq);
ER_ID dtqid = iacre_dtq (T_CDTQ *pk_cdtq);
```

Parameters:

<cre_dtq, icre_dtq>			
ID	dtqid	R4	Data queue ID
T_CDTQ	*pk_cdtq	R5	Pointer to the packet where the data queue creation information is stored
<acre_dtq, iacre_dtq>			
T_CDTQ	*pk_cdtq	R4	Pointer to the packet where the data queue creation information is stored

Return Parameters:

<cre_dtq, icre_dtq>			
ER	ercd	R0	Normal end (E_OK) or error code
<acre_dtq, iacre_dtq>			
ER_ID	dtqid	R0	Created data queue ID (a positive value) or error code

Packet Structure:

```
typedef struct t_cdtq{
    ATR dtqatr;    +0 4    Data queue attribute
    UINT dtqcnt;  +4 4    Size of data queue area (the number of
                        data)
    VP dtq;      +8 4    Start address of data queue area
}T_CDTQ;
```

Error Codes:

E_NOMEM	[k]	Insufficient memory (Data queue area cannot be allocated in the memory)
E_RSATR	[p]	Invalid attribute (dtqatr is invalid)
E_PAR	[p]	Parameter error (pk_cdtq is other than a multiple of four)
	[k]	(dtqcnt × data queue size (4 bytes) exceeds 32-bit area)
E_ID	[p]	Invalid ID number (dtqid ≤ 0 or dtqid > CFG_MAXDTQID)
E_OBJ	[k]	Object status is invalid
		(Data queue indicated by dtqid already exists)
E_NOID	[k]	No ID available

Function:

The service calls `cre_dtq` and `icre_dtq` create a data queue with the ID specified by `dtqid` and with the contents specified by `pk_cdtq`.

The service calls `acre_dtq` and `iacre_dtq` search for an unused data queue ID and create a data queue with that ID and with the contents specified by `pk_cdtq`, and return the ID as a return parameter. The range for searches for unused data queue IDs is from 1 to `CFG_MAXDTQID`.

The attribute `dtqatr` is specified in the following format. See table 3.31 for details.

$$\text{dtqatr} := (\text{TA_TFIFO} \parallel \text{TA_TPRI})$$

Table 3.31 Data Queue Attributes (dtqatr)

dtqatr	Code	Description
TA_TFIFO	H'00000000	Task queue waiting for sending a message is managed on a FIFO basis
TA_TPRI	H'00000001	Task queue waiting for sending a message is managed on priority

Data queue receive-waiting queues are managed in FIFO order. Further, data sent to a data queue is also managed in FIFO order in the data queue, without priority.

`dtqcnt` specifies the number of data items stored in the data queue area. It is also possible to specify a value of 0 for `dtqcnt`; in this case, data send tasks and data receive tasks are completely synchronized.

Data queues are allocated from the data queue area (`CFG_DTQSZ`) specified by the configurator. On successful creation of a data queue, the free data queue area size will decrease by an amount given by the following expression:

$$\text{Decrease in size} = \text{dtqcnt} \times 4 + 16 \text{ bytes}$$

`dtq` is for future expansion; in this kernel, NULL must be specified. If a value other than NULL is used, normal system operation cannot be guaranteed.

Data queues can also be created statically by the configurator.

3.9.2 Delete Data Queue (del_dtq)

C-Language API:

```
ER ercd = del_dtq(ID dtqid);
```

Parameters:

ID	dtqid	R4	Data queue ID
----	-------	----	---------------

Return Parameters:

ER	ercd	R0	Normal end (E_OK) or error code
----	------	----	---------------------------------

Error Codes:

E_ID	[p]	Invalid ID number (dtqid ≤ 0 or dtqid > CFG_MAXDTQID)
E_NOEXS	[k]	Undefined (Data queue indicated by dtqid does not exist)
E_CTX	[k]	Context error (Called from disabled system state)

Function:

The data queue specified by dtqid is deleted.

No error occurs even if there is a send-waiting task or receive-waiting task in the data queue specified by dtqid. However, the WAITING state of the task is cancelled, and an error code E_DLT is returned.

On deletion, the free data queue area size increases by an amount given by the following expression:

$$\text{Increase in size} = \text{dtqcnt specified at creation} \times 4 + 16 \text{ bytes}$$

3.9.3 Send Data to Data Queue (snd_dtq, psnd_dtq, ipsnd_dtq, tsnd_dtq, fsnd_dtq, ifsnd_dtq)

C-Language API:

```
ER ercd = snd_dtq(ID dtqid, VP_INT data);
ER ercd = psnd_dtq(ID dtqid, VP_INT data);
ER ercd = ipsnd_dtq(ID dtqid, VP_INT data);
ER ercd = tsnd_dtq(ID dtqid, VP_INT data, TMO tmout);
ER ercd = fsnd_dtq(ID dtqid, VP_INT data);
ER ercd = ifsnd_dtq(ID dtqid, VP_INT data);
```

Parameters:

ID	dtqid	R4	Data Queue ID
VP_INT	data	R5	Data sent to data queue
<tsnd_dtq>			
TMO	tmout	R6	Timeout specification

Return Parameters:

ER	ercd	R0	Normal end (E_OK) or error code
----	------	----	---------------------------------

Error Codes:

E_PAR	[p]	Parameter error (tmout ≤ -2)
E_ID	[p]	Invalid ID number (dtqid ≤ 0 or dtqid > CFG_MAXDTQID)
E_ILUSE	[k]	Illegal use of service call (fsnd_dtq, ifsnd_dtq is issued for the data queue which dtqcnt is 0)
E_NOEXS	[k]	Undefined (Data queue indicated by dtqid does not exist)
E_CTX	[k]	Context error (Called from disabled system state)
E_DLT	[k]	Waiting object deleted (Target data queue indicated by dtqid has been deleted while waiting)
E_TMOUT	[k]	Polling failed or timeout
E_RLWAI	[k]	WAITING state is forcibly cancelled (rel_wai service call was called in the WAITING state)

Function:

The data specified by the parameter data (4 bytes) is sent to the data queue specified by dtqid.

In addition, when the data queue generated by dtqcnt = 0 is specified, fsnd_dtq and ifsnd_dtq service call generates E_ILUSE error.

1. When the waiting task for reception exists in the target data queue

The data is passed to the head task of receiving queuing and the waiting state of the task is canceled.

2. When the waiting task for reception does not exist in the target data queue

- a) When the data queue is not full

The data specified is stored to the end of the data queue. The counts of the data queue is incremented.

- b) When the data queue is full

- i) snd_dtq, tsnd_dtq

The calling task is connected with queuing for waiting for the empty domain of data queue.

In the case of a service call tsnd_dtq, the wait time is specified to tmout.

If a positive value is specified for the parameter tmout, error code E_TMOUT is returned when the timeout period has passed without the wait release conditions being satisfied.

If tmout = TMO_POL (0) is specified, the same operation as for the service call psnd_dtq will be performed.

If tmout = TMO_FEVR (-1) is specified, timeout monitoring is not performed. In other words, the same operation as for service call snd_dtq will be performed.

When a value larger than 1 is specified for CFG_TICDENO (the denominator for time tick cycles), the maximum value that can be specified for tmout is $H'7fffffff/CFG_TICDENO$. If a value larger than this is specified, operation is not guaranteed.

For detail of time watch method, refer to section 2.16.4(2), Time Watch Method.

- ii) psnd_dtq, ipsnd_dtq

This call returns immediately with E_TMOUT error.

- iii) fsnd_dtq, ifsnd_dtq

The data is stored in the end of data queue after the data of the head of data queue is deleted.

3.9.4 Receive Data from Data Queue (rcv_dtq, prcv_dtq, trcv_dtq)

C-Language API:

```
ER ercd = rcv_dtq(ID dtqid, VP_INT *p_data);
ER ercd = prcv_dtq(ID dtqid, VP_INT *p_data);
ER ercd = trcv_dtq(ID dtqid, VP_INT data, TMO tcout);
```

Parameters:

ID	dtqid	R4	Data queue ID
VP_INT	*p_data	R5	Start address of the area where received data is to be returned
<trcv_dtq>			
TMO	tcout	R6	Timeout specification

Return Parameters:

ER	ercd	R0	Normal end (E_OK) or error code
VP_INT	*p_data	R5	Pointer to the area where received data is stored

Error Codes:

E_PAR	[p]	Parameter error (p_data is other than a multiple of four or tcout ≤ -2)
E_ID	[p]	Invalid ID number (dtqid ≤ 0 or dtqid > CFG_MAXDTQID)
E_NOEXS	[k]	Undefined (Data queue indicated by dtqid does not exist)
E_CTX	[k]	Context error (Called from disabled system state)
E_DLT	[k]	Waiting object deleted (Target data queue indicated by dtqid has been deleted while waiting)
E_TMOU	[k]	Polling failed or timeout
E_RLWAI	[k]	WAITING state is forcibly cancelled (rel_wai service call was called in the WAITING state)

Function:

Data is received from the data queue specified by dtqid, and stored it to the area indicated by parameter p_data.

If there is data in the data queue, the leading data (the oldest message) is received. On receiving data from the data queue, the data queue count is decremented by 1. As a result, if data can be stored for a task in the send-waiting queue, data is sent and processed in the order of the wait queue.

Section3 Service Calls

If there is no data in the data queue, and there exists a data send-waiting task (such a circumstance can occur only when the data queue area capacity is 0), the data of the task at the head of data send-waiting queue is received. As a result, the WAITING state of the data send-waiting task is cancelled.

If there is no data in the data queue, and there are also no data send-waiting tasks, a service call `rcv_dtq` or `trcv_dtq` causes the calling task to be linked to a wait queue to wait for message arrival (receive-waiting queue). In the case of a service call `prcv_dtq`, the call returns immediately with an `E_TMOUT` error. The receive-waiting queue is managed in FIFO order.

In the case of the service call `trcv_dtq`, `tmout` specifies the wait time.

If a positive value is specified for the parameter `tmout`, error code `E_TMOUT` is returned when the timeout period has passed without the wait release conditions being satisfied.

If `tmout = TMO_POL (0)` is specified, the same operation as for the service call `prcv_dtq` will be performed.

If `tmout = TMO_FEVR (-1)` is specified, timeout monitoring is not performed. In other words, the same operation as for service call `rcv_dtq` will be performed.

When a value larger than 1 is specified for `CFG_TICDENO` (the denominator for time tick cycles), the maximum value that can be specified for `tmout` is `H'7ffffff/CFG_TICDENO`. If a value larger than this is specified, operation is not guaranteed.

For detail of time watch method, refer to section 2.16.4(2), Time Watch Method.

3.9.5 Refer to Data Queue State (ref_dtq, iref_dtq)

C-Language API:

```
ER ercd = ref_dtq(ID dtqid, T_RDTQ *pk_rdtq);
ER ercd = ref_dtq(ID dtqid, T_RDTQ *pk_rdtq);
```

Parameters:

ID	dtqid	R4	Data queue ID
T_RDTQ	*pk_rdtq	R5	Pointer to the packet where data queue state is to be returned

Return Parameters:

ER	ercd	R0	Normal end (E_OK) or error code
T_RDTQ	*pk_rdtq	R5	Pointer to the packet where data queue state is stored

Packet Structure:

```
typedef struct t_rdtq{
    ID stskid; 0 2 Task ID waiting for sending
    ID rtskid; +2 2 Task ID waiting for receiving
    UINT sdtqcnt; +4 4 The number of data in the data queue
}T_RDTQ;
```

Error Codes:

E_PAR	[p]	Parameter error (pk_rdtq is other than a multiple of four)
E_ID	[p]	Invalid ID number (dtqid ≤ 0 or dtqid > CFG_MAXDTQID)
E_NOEXS	[k]	Undefined (Data queue indicated by dtqid does not exist)

Function:

The state of the data queue specified by dtqid is referenced, and the send-waiting task IDs (stskid), the receive-waiting task IDs (rtskid), and the number of data items in the data queue (sdtqcnt) are returned to the area specified by pk_rdtq.

If there are no send-waiting tasks or receive-waiting tasks, TSK_NONE(0) is returned as the wait task ID.

3.10 Synchronization and Communication (Mailbox)

Mailbox Service Calls: Mailboxes are controlled by the service calls listed in table 3.32.

Table 3.32 Service Calls for Mailbox Control

Service Call ¹	Description	System State ²
		T/N/E/D/U/L/C
cre_mbx [s]	Creates mailbox	T/E/D/U
icre_mbx		N/E/D/U
acre_mbx	Creates mailbox and assigns mailbox ID automatically	T/E/D/U
iacre_mbx		N/E/D/U
del_mbx	Deletes mailbox	T/E/D/U
snd_mbx [S]	Sends data to mailbox	T/E/D/U
isnd_mbx		N/E/D/U
rcv_mbx [S]	Receives data from mailbox	T/E/U
prcv_mbx [S]	Polls and receives data from mailbox	T/E/D/U
iprcv_mbx		N/E/D/U
trcv_mbx [S]	Receives data from mailbox with timeout function	T/E/U
ref_mbx	Refers to mailbox state	T/E/D/U
iref_mbx		N/E/D/U

Notes: 1. [S]: Standard profile service calls
 [s]: Service calls that are not standard profile service calls but are needed in order to use the standard profile function

2. T: Can be called from task context
 N: Can be called from non-task context
 E: Can be called from dispatch-enabled state
 D: Can be called from dispatch-disabled state
 U: Can be called from CPU-unlocked state
 L: Can be called from CPU-locked state
 C: Can be called from CPU exception handler

Mailbox Specifications: The mailbox specifications are listed in table 3.33.

Table 3.33 Mailbox Specifications

Item	Description
Mailbox ID	1 to CFG_MAXMBXID (1023 max.)
Message priority	1 to CFG_MAXMSGPRI* (255 max.)
Attribute supported	TA_TFIFO: Task wait queue is managed on a FIFO basis TA_TPRI: Task wait queue is managed on priority TA_MFIFO: Message queue is managed on a FIFO basis TA_MPRI: Message queue is managed on priority

Note: This value is the same as TMAX_MPRI defined in kernel_macro.h.

3.10.1 Create Mailbox**(cre_mbx, icre_mbx)****(acre_mbx, iacre_mbx: Assign Mailbox ID Automatically)****C-Language API:**

```

ER ercd = cre_mbx(ID mbxid, T_CMBX *pk_cmbx);
ER ercd = icre_mbx(ID mbxid, T_CMBX *pk_cmbx);
ER_ID mbxid = acre_mbx(T_CMBX *pk_cmbx);
ER_ID mbxid = iacre_mbx(T_CMBX *pk_cmbx);

```

Parameters:

```

<cre_mbx, icre_mbx>
ID          mbxid          R4  Mailbox ID
T_CMBX      *pk_cmbx      R5  Pointer to the packet where the mailbox
      creation information is stored

<acre_mbx, iacre_mbx>
T_CMBX      *pk_cmbx      R4  Pointer to the packet where the mailbox
      creation information is stored

```

Return Parameters:

```

<cre_mbx, icre_mbx>
ER          ercd          R0  Normal end (E_OK) or error code

<acre_mbx, iacre_mbx>
ER_ID      mbxid         R0  Created mailbox ID (a positive value) or
      error code

```

Packet Structure:

```

typedef      struct      t_cmbx{
      ATR          mbxatr;  +0  4  Mailbox attribute
      PRI          maxmpri; +4  2  Maximum value of message priority
      VP          mprihd;  +8  4  Start address of message queue header
      with priority
}T_CMBX;

```

Error Codes:

```

E_RSATR    [p]  Invalid attribute (mbxatr is invalid)
E_PAR      [p]  Parameter error (pk_cmbx is other than a multiple of four,
      maxmpri ≤ 0, or maxmpri > CFG_MAXMSGPRI)
E_ID       [p]  Invalid ID number (mbxid ≤ 0 or mbxid > CFG_MAXMBXID)
E_OBJ      [k]  Object status is invalid
      (Mailbox indicated by mbxid already exists)
E_NOID     [k]  No ID available

```

Function:

Service calls `cre_mbx` and `icre_mbx` create a mailbox with an ID indicated by `mbxid` with the contents indicated by `pk_cmbx`.

Service calls `acre_mbx` and `iacre_mbx` search for an unused mailbox ID and create a mailbox that has this ID, with the contents specified by parameter `pk_cmbx`. The created mailbox ID is returned as a return parameter. The range for searching for an unused mailbox ID is 1 to `CFG_MAXMBXID`.

Parameter `mbxatr` is specified in the following format. See table 3.34 for details.

`mbxatr := ((TA_TFIFO || TA_TPRI) | TA_MFIFO || TA_MPRI)`

Table 3.34 Mailbox Attributes (mbxatr)

mbxatr	Code	Description
TA_TFIFO	H'00000000	Message receive wait queue is managed on a FIFO basis
TA_TPRI	H'00000001	Message receive wait queue is managed on priority
TA_MFIFO	H'00000000	Message queue is managed on a FIFO basis
TA_MPRI	H'00000002	Message queue is managed on priority

When `TA_MPRI` is specified for `mbxatr`, `NULL` must be specified for `mprihd`. The message-queue header area is created in the area specified by `mprihd` when a value other than `NULL` is specified by the μ TRON4.0 specification. However, the kernel does not support a value other than `NULL`. If a value other than `NULL` is used, normal system operation cannot be guaranteed. If `TA_MPRI` is not specified, `mprihd` does not have any meaning and is simply ignored.

A mailbox can also be created statically by the configurator.

3.10.2 Delete Mailbox (del_mbx)

C-Language API:

```
ER ercd = del_mbx(ID mbxid);
```

Parameters:

ID	mbxid	R4	Mailbox ID
----	-------	----	------------

Return Parameters:

ER	ercd	R0	Normal end (E_OK) or error code
----	------	----	---------------------------------

Error Codes:

E_ID	[p]	Invalid ID number (mbxid ≤ 0 or mbxid > CFG_MAXMBXID)
E_NOEXS	[k]	Undefined (Mailbox indicated by mbxid does not exist)
E_CTX	[k]	Context error (Called from disabled system state)

Function:

Service call del_mbx deletes the mailbox indicated by parameter mbxid.

No error will occur even if there is a task waiting for a message in the mailbox indicated by mbxid. However, in that case, the task in the WAITING state will be released and error code E_DLT will be returned. If there is a message in the mailbox, no error will occur, but the kernel will not perform any processing for the message area. For example, the kernel will not automatically return the message area to the memory pool when a memory block acquired from the memory pool is used for a message.

3.10.3 Send Message to Mailbox (snd_mbx, isnd_mbx)

C-Language API:

```
ER ercd = snd_mbx(ID mbxid, T_MSG *pk_msg);
ER ercd = isnd_mbx(ID mbxid, T_MSG *pk_msg);
```

Parameters:

ID	mbxid	R4	Mailbox ID
T_MSG	*pk_msg	R5	Start address of the message to be sent

Return Parameters:

ER	ercd	R0	Normal end (E_OK) or error code
----	------	----	---------------------------------

Packet Structure:

```
Mailbox message header
typedef      struct  t_msg{
                VP      msghead; +0  4      Kernel management area
            }T_MSG;
Mailbox message header with priority
typedef      struct  t_msg_pri{
                T_MSG  msgque;  +0  4      Message header
                PRI    msgpri;  +4  2      Message priority
            }T_MSG PRI;
```

Error Codes:

E_PAR	[p]	Parameter error (pk_msg is other than a multiple of four or the first four bytes of the message is other than 0)
	[k]	(msgpri ≤ 0, msgpri > CFG_MAXMSGPRI)
E_ID	[p]	Invalid ID number (mbxid ≤ 0, mbxid < 0, or mbxid > CFG_MAXMBXID)
E_NOEXS	[k]	Undefined (Mailbox indicated by mbxid does not exist)

Function:

Each service call sends a message specified by pk_msg to the mailbox specified by mbxid.

If there is a task waiting to receive a message in the mailbox, the task at the head of the wait queue receives the message and is released from the WAITING state. On the other hand, if there are no tasks waiting to receive a message, the message specified by pk_msg is linked to the end of the message queue. The message queue is managed according to the attributes specified at creation.

To send a message to a mailbox that has the TA_MFIFO attribute, the message must be created in RAM and must have the T_MSG structure at the head of the message, as shown in figure 3.4. The contents of T_MSG must be 0 when sending a message.

To send a message to a mailbox that has the TA_MPRI attribute, the message must be created in RAM and must have the T_MSG_PRI structure at the head of the message, as shown in figure 3.5. The contents of T_MSG must be 0 when sending a message.

Note that the T_MSG area is used by the kernel; therefore the area must not be modified after message transfer. If this area is modified, normal system operation cannot be guaranteed.

```
typedef struct user_msg {
    T_MSG t_msg; /* T_MSG structure */
    B data[8]; /* Example of user message data structure */
} USER_MSG;
```

Figure 3.4 Example of a Message Form

```
typedef struct user_msg {
    T_MSG_PRI t_msg; /* T_MSG structure
*/
    B data[8]; /* Example of user message data structure
*/
} USER_MSG;
```

Figure 3.5 Example of a Message Form with Priority

3.10.4 Receive Message from Mailbox (rcv_mbx, prcv_mbx, iprcv_mbx, trcv_mbx)

C-Language API:

```
ER ercd = rcv_mbx(ID mbxid, T_MSG **ppk_msg);
ER ercd = prcv_mbx(ID mbxid, T_MSG **ppk_msg);
ER ercd = iprcv_mbx(ID mbxid, T_MSG **ppk_msg);
ER ercd = trcv_mbx(ID mbxid, T_MSG **ppk_msg, TMO tmout);
```

Parameters:

ID	mbxid	R4	Mailbox ID
T_MSG	**ppk_msg	R5	Pointer to the area where the start address of the received message is to be returned
<trcv_mbx>			
TMO	tmout	R6	Timeout specification

Return Parameters:

ER	ercd	R0	Normal end (E_OK) or error code
T_MSG	**ppk_msg	R5	Pointer to the area where the start address of the received message is stored

Packet Structure:

```
<Mailbox message header>
typedef struct t_msg{
    VP msghead; +0 4 Kernel management area
}T_MSG;
<Mailbox message header with priority>
typedef struct t_msg_pri{
    T_MSG msgque; +0 4 Message header
    PRI msgpri; +4 2 Message priority
}T_MSG PRI;
```

Error Codes:

E_PAR	[p]	Parameter error (ppk_msg is other than a multiple of four or tmout ≤ -2)
E_ID	[p]	Invalid ID number (mbxid ≤ 0 or mbxid > CFG_MAXMBXID)
E_NOEXS	[k]	Undefined (Mailbox indicated by mbxid does not exist)
E_CTX	[k]	Context error (Called from disabled system state)
E_DLT	[k]	Waiting object deleted (Mailbox indicated by mbxid has been deleted in the WAITING state)
E_TMOUT	[k]	Polling failed or timeout
E_RLWAI	[k]	WAITING state is forcibly cancelled (rel_wai service call was called in the WAITING state)

Function:

Each service call receives a message from the mailbox specified by parameter `mbxid`. Then the start address of the received message is returned to the area indicated by parameter `pk_msg`.

With service calls `rcv_mbx` and `trcv_mbx`, if there are no messages in the mailbox, the task that called the service call is placed in the wait queue to receive a message. With service calls `prcv_mbx` and `iprcv_mbx`, if there are no messages in the mailbox, error code `E_TMOUT` is returned immediately. The wait queue is managed according to the attributes specified at creation.

Parameter `tmout` specified by service call `trcv_mbx` specifies the timeout period.

If a positive value is specified for parameter `tmout`, error code `E_TMOUT` is returned when the timeout period has passed without the wait release conditions being satisfied.

If `tmout = TMO_POL (0)` is specified, the same operation as for service call `prcv_mbx` will be performed.

If `tmout = TMO_FEVR (-1)` is specified, timeout monitoring is not performed. In other words, the same operation as for service call `rcv_mbx` will be performed.

If a value larger than 1 is specified for `CFG_TICDENO` (the denominator for time tick cycles), the maximum value that can be specified for `tmout` is `H'7fffffff/CFG_TICDENO`. If a value larger than this is specified, operation is not guaranteed.

For detail of time watch method, refer to section 2.16.4(2), Time Watch Method.

3.10.5 Refer to Mailbox State (ref_mbx, iref_mbx)

C-Language API:

```
ER ercd = ref_mbx(ID mbxid , T_RMBX *pk_rmbx);
```

```
ER ercd = iref_mbx(ID mbxid , T_RMBX *pk_rmbx);
```

Parameters:

ID	mbxid	R4	Mailbox ID
T_RMBX	*pk_rmbx	R5	Pointer to the area where the mailbox state is to be returned

Return Parameters:

ER	ercd	R0	Normal end (E_OK) or error code
T_RMBX	*pk_rmbx	R5	Pointer to the packet where the mailbox state is stored

Packet Structure:

(1) T_RMBX

```
typedef struct t_rmbx{
    ID      wtskid;    +0  2  Wait task ID
    T_MSG   *pk_msg;   +4  4  Start address of the message to be
                                received next
}
```

}T_RMBX;

(2) T_MSG

<Mailbox message header>

```
typedef struct t_msg{
    VP      msghead;  +0  4  Kernel management area
}
```

}T_MSG;

<Mailbox message header with priority>

```
typedef struct t_msg_pri{
    T_MSG   msgque;    +0  4  Message header
    PRI     msgpri;    +4  2  Message priority
}
```

}T_MSG_PRI;

Error Codes:

E_PAR	[p]	Parameter error (pk_rmbx is other than a multiple of four)
E_ID	[p]	Invalid ID number (mbxid ≤ 0 or mbxid > CFG_MAXMBXID)
E_NOEXS	[k]	Undefined (Mailbox indicated by mbxid does not exist)

Function:

Each service call refers to the state of the mailbox indicated by parameter mbxid.

Service calls ref_mbx and iref_mbx return the wait task ID (wtskid) and the start address of the message to be received next (pk_msg) to the area indicated by pk_rmbx.

If there is no task waiting for the specified message, TSK_NONE (0) is returned as a wait task ID.

If there is no message to be received next, NULL (0) is returned as a message start address.

3.11 Synchronization and Communication (Mutex)

Mutex Service Calls: Mutexes are controlled by the service calls listed in table 3.35.

Table 3.35 Service Calls for Mutex Control

Service Call ¹	Description	System State ²
		T/N/E/D/U/L/C
cre_mtx	Creates mutex	T/E/D/U
acre_mtx	Creates mutex and assigns mutex ID automatically	T/E/D/U
del_mtx	Deletes mutex	T/E/D/U
loc_mtx	Locks mutex	T/E/U
ploc_mtx	Polls and locks mutex	T/E/D/U
tlloc_mtx	Locks mutex with timeout function	T/E/U
unl_mtx	Unlocks mutex	T/E/D/U
ref_mtx	Refers to mutex state	T/E/D/U

- Notes: 1. [S]: Standard profile service calls
 [s]: Service calls that are not standard profile service calls but are needed in order to use the standard profile function
2. T: Can be called from task context
 N: Can be called from non-task context
 E: Can be called from dispatch-enabled state
 D: Can be called from dispatch-disabled state
 U: Can be called from CPU-unlocked state
 L: Can be called from CPU-locked state
 C: Can be called from CPU exception handler

Mutex Specifications: The mutex specifications are listed in table 3.36.

Table 3.36 Mutex Specifications

Item	Description
Mutex ID	1 to CFG_MAXMTXID (1023 max.)
Attribute supported	TA_CEILING (Ceiling priority protocol)

Note: When the TA_CEILING attribute is specified, the mutex is managed by "simplified priority control rule". Under this rule, the management which changes the task's current priority to higher value is always operated, but the management which changes the task's priority to lower value is not operated only when the task releases all of mutexes.

3.11.1 Create Mutex (cre_mtx) (acre_mtx: Assign Mutex ID Automatically)

C-Language API:

```
ER ercd = cre_mtx(T_CMTX *pk_cmtx);
ER_ID mtxid = acre_mtx(T_CMTX *pk_cmtx);
```

Parameters:

```
<cre_mtx>
ID          mtxid      R4      Mutex ID
T_CMTX     *pk_cmtx   R5      Pointer to the packet where the mutex
        creation information is stored

<acre_mtx >
T_CMTX     *pk_cmtx   R4      Pointer to the packet where the mutex
        creation information is stored
```

Return Parameters:

```
<cre_mtx>
ER          ercd      R0      Normal end (E_OK) or error code

<acre_mtx>
ER_ID      mtxid     R0      Created mutex ID (a positive value) or
        error code
```

Packet Structure:

```
typedef struct t_cmtx{
    ATR      mtxatr;  +0  4      Mutex attribute
    PRI      ceilpri; +4  2      Ceiling priority of mutex
}T_CMTX;
```

Error Codes:

```
E_RSATR    [p]    Invalid attribute (mtxatr is invalid)
E_PAR      [p]    Parameter error (pk_cmtx is other than a multiple of four
        ceilpri ≤ 0 ceilpri > CFG_MAXTSKPRI)
E_ID       [p]    Invalid ID number (mtxid ≤ 0 or mtxid > CFG_MAXMTXID)
E_OBJ      [k]    Object status is invalid
        (Mutex indicated by mtxid already exists)
E_NOID     [k]    No ID available
```

Function:

Service call `cre_mtx` creates a mutex that has the ID specified by `mtxid` and with the contents specified by `pk_cmtx`.

Service call `acre_mtx` searches for an unused mutex ID and creates a mutex having that ID and with the contents specified by `pk_cmtx`, and returns the ID as a return parameter. The range for searching for an unused mutex ID is from 1 to `CFG_MAXMTXID`.

As the `mtxatr` attribute, only the ceiling priority protocol (`TA_CEILING`) can be specified.

`mtxatr := (TA_CEILING)`

Table 3.37 **Mutex Attribute (mtxatr)**

mtxatr	Code	Description
<code>TA_CEILING</code>	<code>H'00000003</code>	Ceiling priority protocol

`ceilpri` specifies the ceiling priority for the mutex to be created. The range of values which can be specified is 1 to `CFG_MAXTSKPRI`.

A mutex can also be created statically by the configurator.

3.11.2 Delete Mutex (del_mtx)

C-Language API:

```
ER ercd = del_mtx(ID mtxid);
```

Parameters:

ID	mtxid	R4	Mutex ID
----	-------	----	----------

Return Parameters:

ER	ercd	R0	Normal end (E_OK) or error code
----	------	----	---------------------------------

Error Codes:

E_ID	[p]	Invalid ID number (mtxid ≤ 0 or mtxid > CFG_MAXMTXID)
E_NOEXS	[k]	Undefined (Mutex indicated by mtxid does not exist)
E_CTX	[k]	Context error (Called from disabled system state)

Function:

Service call del_mtx deletes the mutex specified by parameter mtxid.

No error occurs even when there is a lock-waiting task for the mutex specified by mtxid; but the WAITING state of the task is cancelled, and E_DLT is returned as an error code.

When the target mutex is locked, the lock for the task locked by the mutex is cancelled. As a result, only when all mutexes locking the task are removed, the task priority is returned to base priority.

The task locked by the deleted mutex is not notified that the mutex has been deleted. If an attempt is later made to release the mutex lock, an error is returned.

3.11.3 Lock Mutex (loc_mtx, ploc_mtx, tloc_mtx)

C-Language API:

```
ER ercd = loc_mtx(ID mtxid);  
ER ercd = ploc_mtx(ID mtxid);  
ER ercd = tloc_mtx(ID mtxid, TMO tmout);
```

Parameters:

ID	mtxid	R4	Mutex ID
<tloc_mtx>			
TMO	tmout	R5	Timeout specification

Return Parameters:

ER	ercd	R0	Normal end (E_OK) or error code
----	------	----	---------------------------------

Error Codes:

E_PAR	[p]	Parameter error (tmout ≤ -2)
E_ID	[p]	Invalid ID (mtxid ≤ 0, mtxid > CFG_MAXMTXID)
E_NOEXS	[k]	Undefined (Mutex indicated by mtxid does not exist)
E_ILUSE	[k]	Illegal use of service call (The mutex specified by mtxid is already locked by the calling task, or the base priority of the calling task is less than the ceiling priority of the target mutex.)
E_CTX	[k]	Context error (Called from disabled system state)
E_DLT	[k]	Waiting object deleted (Mutex indicated by mtxid has been deleted in the WAITING state)
E_RLWAI	[k]	The WAITING state was forcibly cancelled (rel_wai service call was called in the WAITING state)
E_TMOUT	[k]	Polling failed or timeout

Function:

Service calls loc_mtx, ploc_mtx and tloc_mtx lock the mutex specified by parameter mtxid.

If the target mutex is not locked, the current task locks the mutex, and the service call processing is completed. At this time, the priority of the current task is raised to the ceiling priority of the mutex.

If the target mutex is locked, the current task is placed in a wait queue, and the current task enters the mutex lock-wait state. The wait queue is managed in priority order.

Parameter tmout specified by service call tloc_mtx specifies the timeout period.

If a positive value is specified for parameter tmout, error code E_TMOUT is returned when the timeout period has passed without the wait release conditions being satisfied.

If tmout = TMO_POL (0) is specified, the same operation as for service call ploc_mtx will be performed.

If `tmout = TMO_FEVR (-1)` is specified, timeout monitoring is not performed. In other words, the same operation as for service call `loc_mtx` will be performed.

When a value larger than 1 is specified for `CFG_TICDENO` (the denominator for time tick cycles), the maximum value that can be specified for `tmout` is $H'7ffffff/CFG_TICDENO$. If a value larger than this is specified, operation is not guaranteed.

For detail of time watch method, refer to section 2.16.4(2), Time Watch Method.

3.11.4 Unlock Mutex (unl_mtx)

C-Language API:

```
ER ercd = unl_mtx(ID mtxid);
```

Parameters:

ID	mtxid	R4	Mutex ID
----	-------	----	----------

Return Parameters:

ER	ercd	R0	Normal end (E_OK) or error code
----	------	----	---------------------------------

Error Codes:

E_ID	[p]	Invalid ID (mtxid ≤ 0, mtxid > CFG_MAXMTXID)
E_NOEXS	[k]	Undefined (Mutex indicated by mtxid does not exist)
E_ILUSE	[k]	Illegal use of service call (Duplicate lock of mutex or highest priority is exceeded)
E_CTX	[k]	Context error (Called from disabled system state)

Function:

The lock for the mutex specified by mtxid is released. If there are tasks waiting for the lock for the specified mutex, the WAITING state for the task at the head of the mutex wait queue is released, and the task whose WAITING state has been released is put into a state which locks the mutex. At this time, the priority of the locking task is raised to the ceiling priority of the mutex. If there are no tasks waiting for the mutex, the mutex is put into the unlocked state.

The simplified priority ceiling protocol is used for the TA_CEILING attribute of this kernel. That is, only when all the mutex that are locked by the task are unlocked, the present priority of the task is returned to a base priority. When the task still locks other mutex after this call, the present priority does not change in this service call.

3.11.5 Refer to Mutex State (ref_mtx)

C-Language API:

```
ER ercd = ref_mtx(ID mtxid, T_RMTX *pk_rmtx);
```

Parameters:

ID	mtxid	R4	Mutex ID
T_RMTX	*pk_rmtx	R5	Pointer to the area where the mutex status is to be returned

Return Parameters:

ER	ercd	R0	Normal end (E_OK) or error code
T_RMTX	*pk_rmtx	R5	Pointer to the packet where the mutex status is stored

Packet Structure:

```
typedef struct t_rmtx{
    ID htskid; +0 2 Task ID locking a mutex
    ID wtskid; +2 2 Start task ID of mutex waiting queue
}T_RMTX;
```

Error Codes:

E_PAR	[p]	Parameter error (pk_rmtx is other than a multiple of four)
E_ID	[p]	Invalid ID number (mtxid ≤ 0 or mtxid > CFG_MAXMTXID)
E_NOEXS	[k]	Undefined (Mutex indicated by mtxid does not exist)

Function:

Service call ref_mtx refers to the state of the mutex. Service call ref_mtx returns the task ID that locks the mutex (htskid) and the start task ID of the mutex wait queue (wtskid) to the area indicated by pk_rmtx. If there is no task that locks the target mutex, TSK_NONE (0) is returned to the htskid. If there is no task waiting for the target mutex, TSK_NONE (0) is returned to the wtskid.

3.12 Extended Synchronization and Communication (Message Buffer)

Message Buffer Service Calls: Message Buffers are controlled by the service calls listed in table 3.38.

Table 3.38 Service Calls for Message Buffer Control

Service Call ¹	Description	System State ²
		T/N/E/D/U/L/C
cre_mbf	Creates message buffer	T/E/D/U
icre_mbf		N/E/D/U
acre_mbf	Creates message buffer and assigns message	T/E/D/U
iacre_mbf	buffer ID automatically	N/E/D/U
del_mbf	Deletes message buffer	T/E/D/U
snd_mbf	Sends message to message buffer	T/E/U
psnd_mbf	Polls and sends message to message buffer	T/E/D/U
ipsnd_mbf		N/E/D/U
tsnd_mbf	Sends message to message buffer with timeout function	T/E/U
rcv_mbf	Receives message from message buffer	T/E/U
prcv_mbf	Polls and receives message from message buffer	T/E/D/U
trcv_mbf	Receives message from message buffer with timeout function	T/E/U
ref_mbf	Refers to message buffer state	T/E/D/U
iref_mbf		N/E/D/U

- Notes: 1. [S]: Standard profile service calls
 [s]: Service calls that are not standard profile service calls but are needed in order to use the standard profile function
2. T: Can be called from task context
 N: Can be called from non-task context
 E: Can be called from dispatch-enabled state
 D: Can be called from dispatch-disabled state
 U: Can be called from CPU-unlocked state
 L: Can be called from CPU-locked state
 C: Can be called from CPU exception handler

Message Buffer Specifications: The message buffer specifications are listed in table 3.39.

Table 3.39 Message Buffer Specifications

Item	Description
Message buffer ID	1 to CFG_MAXMBFID (1023 max.)
Attribute supported	TA_TFIFO: Task queue waiting for sending a message is managed on a FIFO basis TA_TPRI: Task queue waiting for sending a message is managed on priority

3.12.1 Create Message Buffer**(cre_mbf, icre_mbf)****(acre_mbf, iacre_mbf: Assign Message Buffer ID Automatically)****C-Language API:**

```

ER ercd = cre_mbf(ID mbfid, T_CMBF *pk_cmbf);
ER ercd = icre_mbf(ID mbfid, T_CMBF *pk_cmbf);
ER_ID mbfid = acre_mbf(T_CMBF *pk_cmbf);
ER_ID mbfid = iacre_mbf(T_CMBF *pk_cmbf);

```

Parameters:

```

<cre_mbf, icre_mbf>
ID          mbfid      R4    Message buffer ID
T_CMBF     *pk_cmbf   R5    Pointer to the packet where the message buffer
      creation information is stored

<acre_mbf, iacre_mbf>
T_CMBF     *pk_cmbf   R4    Pointer to the packet where the message buffer
      creation information is stored

```

Return Parameters:

```

<cre_mbf, icre_mbf>
ER          ercd       R0    Normal end (E_OK) or error code

<acre_mbf, iacre_mbf>
ER_ID      mbfid       R0    Created message buffer ID (a positive value) or
      error code

```

Packet Structure:

```

typedef struct t_cmbf{
    ATR      mbfatr;    +0   4   Message buffer attribute
    UINT     maxmsz;   +4   4   Maximum message size (Number of bytes)
    SIZE     mbfsz;    +8   4   Message buffer size (Number of bytes)
    VP       mbf;      +12  4   Start address of message buffer area
}T_CMBF;

```

Error Codes:

```

E_NOEMEM [k] Insufficient memory (Message buffer area cannot be allocated
      in the memory)
E_RSATR [p] Invalid attribute (mbfatr is invalid)
E_PAR [p] Parameter error (pk_cmbf is other than a multiple of four,
      mbfsz is other than a multiple of four, maxmsz = 0,
      maxmsz ≥ H'80000000, or mbfsz is other than 0 and maxmsz + 4 >
      mbfsz)
E_ID [p] Invalid ID number (mbfid ≤ 0 or mbfid > CFG_MAXMBFID)
E_OBJ [k] Object status is invalid
      (Message buffer indicated by mbfid already exists)
E_NOID [k] No ID available

```

Function:

Service calls `cre_mbf` and `icre_mbf` create a message buffer with an ID indicated by `mbfid` with the contents specified by `pk_cmbf`.

Service calls `acre_mbf` and `iacre_mbf` search for an unused message buffer ID and create a message buffer that has this ID, with the contents specified by parameter `pk_cmbf`. The created event flag ID is returned as a return parameter. The range for searching for an unused message buffer ID is 1 to `CFG_MAXMBFID`.

Parameter `mbfatr` is specified in the following format. See table 3.40 for details.

$$\text{mbfatr} := (\text{TA_TFIFO} \parallel \text{TA_TPRI})$$

Table 3.40 Message Buffer Attributes (mbfatr)

mbfatr	Code	Description
TA_TFIFO	H'00000000	Task queue waiting for sending a message is managed on a FIFO basis
TA_TPRI	H'00000001	Task queue waiting for sending a message is managed on priority

The message queue and the task queue waiting for sending a message are managed on a first-in first-out (FIFO) basis regardless of the `mbfatr` specification.

A message buffer is created in the message buffer area (`CFG_MBFSZ`) specified by the configurator. After the message buffer has been created, the free message buffer area size will decrease by the amount given by the following expression:

$$\text{Decrease in size} = \text{mbfsz} + 16 \text{ bytes}$$

Section3 Service Calls

Parameter `mbfsz` specifies the size of the message buffer to be created. This must be a multiple of four and equal to or more than the minimum buffer size (8 bytes). When calculating the message buffer size, remember that 4 bytes of management area for the kernel is added when one message is stored. A message buffer of `mbfsz = 0` can also be created. In this case, no message can be stored in the message buffer, and the message-receiving task completely synchronizes with the message sending task. In other words, when a service call to send a message is called, the task stays in the WAITING state until another task calls a service call to receive a message. Similarly, when a task calls a service call to receive a message the task stays in the WAITING state until another task calls a service call to send a message. Note that for a message buffer with `mbfsz = 0`, there will be no copying via the message buffer.

Parameter `maxmsz` specifies the maximum message size that can be received by the created message buffer.

NULL must be specified for parameter `mbf`. The message buffer is created in the area specified by `mbf` by the μ TRON4.0 specification. However, the kernel does not support a value other than NULL. If a value other than NULL is used, normal system operation cannot be guaranteed.

A message buffer can also be created statically by the configurator.

3.12.2 Delete Message Buffer (del_mbf)

C-Language API:

```
ER ercd = del_mbf(ID mbfid);
```

Parameters:

ID	mbfid	R4	Message buffer ID
----	-------	----	-------------------

Return Parameters:

ER	ercd	R0	Normal end (E_OK) or error code
----	------	----	---------------------------------

Error Codes:

E_ID	[p]	Invalid ID number (mbfid ≤ 0 or mbfid > CFG_MAXMBFID)
E_NOEXS	[k]	Undefined (Message buffer indicated by mbfid does not exist)
E_CTX	[k]	Context error (Called from disabled system state)

Function:

Service call del_mbf deletes the message buffer indicated by parameter mbfid.

No error will occur even if there is a task waiting for receiving or sending a message in the message buffer indicated by mbfid. However, in that case, the task in the WAITING state will be released and error code E_DLT will be returned. In addition, if there is a message in the message buffer, no error will occur, but all stored messages will be deleted.

The size of the free message buffer area will increase by an amount given by the following expression after a message buffer is deleted.

$$\text{Increase in size} = \text{mbfsz defined at creation} + 16 \text{ bytes}$$

3.12.3 Send Message to Message Buffer (snd_mbf, psnd_mbf, ipsnd_mbf, tsnd_mbf)

C-Language API:

```
ER ercd = snd_mbf(ID mbfid, VP msg, UINT msgsz);
ER ercd = psnd_mbf(ID mbfid, VP msg, UINT msgsz);
ER ercd = ipsnd_mbf(ID mbfid, VP msg, UINT msgsz);
ER ercd = tsnd_mbf(ID mbfid, VP msg, UINT msgsz, TMO tmout);
```

Parameters:

ID	mbfid	R4	Message buffer ID
VP	msg	R5	Start address of the message to send
UINT	msgsz	R6	Size of the message to send (number of bytes)
<tsnd_mbf>			
TMO	tmout	R7	Timeout specification

Return Parameters:

ER	ercd	R0	Normal end (E_OK) or error code
----	------	----	---------------------------------

Error Codes:

E_PAR	[p]	Parameter error (msg is other than a multiple of four, msgsz = 0, or tmout ≤ -2)
	[k]	(msgsz > maxmsz')
E_ID	[p]	Invalid ID number (mbfid ≤ 0 or mbfid > CFG_MAXMBFID)
E_NOEXS	[k]	Undefined (Message buffer indicated by mbfid does not exist)
E_CTX	[k]	Context error (Called from disabled system state)
E_DLT	[k]	Waiting object deleted (Message buffer indicated by mbfid has been deleted during the WAITING state)
E_TMOUT	[k]	Polling failed or timeout
E_RLWAI	[k]	WAITING state is forcibly cancelled (rel_wai service call was called in the WAITING state)

Note: maxmsz: Maximum message size specified at message buffer creation

Function:

Each service call sends a message specified by msg to the message buffer specified by mbfid. The message size is specified by parameter msgsz.

If there are no tasks waiting to send a message but there is a task waiting to receive a message, the message sent by the service call is not placed in the message buffer. Instead, the message is passed to the task at the head of the receive wait queue, releasing the task from the WAITING state.

If there are already tasks waiting to send a message to the message buffer, the task that called service call `snd_mbf` or `tsnd_mbf` is placed in the queue to wait for free space in the message buffer. With service calls `psnd_mbf` and `ipsnd_mbf`, error code `E_TMOU` is immediately returned. The wait queue is managed according to the attribute specified at task creation.

If there are no tasks waiting to send or receive a message, the message sent from a task is stored in the message buffer.

After the message has been stored in the message buffer, the size of the message buffer free space will decrease by an amount given by the following expression:

$$\text{Decrease in size} = \text{msgsz} + 4 \text{ bytes}$$

However, if the free space in the message buffer is less than the above size (including when the buffer size is 0), the task that called the service call is placed in the queue to wait for message buffer free space.

`ipsnd_mbf` can also be issued from a non-task context. Since the priority of a non-task context is higher than that of a task, when the target message buffer has `TA_TPRI` attribute and the buffer has enough free size for required size (`msgsz + 4`), the specified message is copied to the buffer even if there exists a task that has been waiting to be transmitted.

In service call `tsnd_mbf`, parameter `tmout` specifies the timeout time. If a positive value is specified for parameter `tmout`, error code `E_TMOU` is returned when the `tmout` time has passed without the wait release conditions being satisfied.

If `tmout = TMO_POL (0)` is specified, the same operation as for service call `psnd_mbf` will be performed.

If `tmout = TMO_FEVR (-1)` is specified, the same operation as for service call `snd_mbf` will be performed. In other words, timeout monitoring is not performed.

If a value larger than 1 is specified for `CFG_TICDENO` (the denominator for time tick cycles), the maximum value that can be specified for `tmout` is `H'7fffffff/CFG_TICDENO`. If a value larger than this is specified, operation is not guaranteed.

For detail of time watch method, refer to section 2.16.4(2), Time Watch Method.

3.12.4 Receive Message from Message Buffer (rcv_mbf, prcv_mbf, trcv_mbf)

C-Language API:

```
ER_UINT msgsz = rcv_mbf(ID mbfid, VP msg);
ER_UINT msgsz = prcv_mbf(ID mbfid, VP msg);
ER_UINT msgsz = trcv_mbf(ID mbfid, VP msg, TMO tmo);
```

Parameters:

ID	mbfid	R4	Message buffer ID
VP	msg	R5	Start address of the area where the received message is to be returned
<trcv_mbf>			
TMO	tmo	R6	Timeout specification

Return Parameters:

ER_UINT	msgsz	R0	Size of the received message (number of bytes, a positive value) or error code
VP	msg	R5	Start address of the area where the received message is stored

Error Codes:

E_PAR	[p]	Parameter error (msg is other than a multiple of four or tmo ≤ -2)
E_ID	[p]	Invalid ID number (mbfid ≤ 0 or mbfid > CFG_MAXMBFID)
E_NOEXS	[k]	Undefined (Message buffer indicated by mbfid does not exist)
E_CTX	[k]	Context error (Called from disabled system state)
E_DLT	[k]	Waiting object deleted (Target message buffer indicated by mbfid has been deleted during the WAITING state)
E_TMOUT	[k]	Polling failed or timeout
E_RLWAI	[k]	WAITING state is forcibly cancelled (rel_wai service call was called in the WAITING state)

Function:

Each service call receives a message from the message buffer specified by parameter mbfid and stores the received message in the area indicated by msg. The received message size is returned as the return parameter.

If there are already messages in the message buffer, the task receives the message of the head of the queue (the oldest message).

After the message has been received, the free space size of the message buffer will increase by an amount given by the following expression:

$$\text{Increase in size} = \text{msgsz} + 4 \text{ bytes}$$

If, as a result, the free space in the message buffer becomes larger than the size of the message to be sent by the task at the head of the send wait queue, the message is sent and stored in the message buffer and the task is released from the WAITING state. The same will be done for the remaining tasks in the order of the wait queue if the message can be stored.

If there are no messages in the message buffer and there are tasks waiting to send a message, the message of the task at the head of the wait queue is received by the service call. As a result, the task is released from the WAITING state.

If there are no messages in the message buffer and there are no tasks in the queue to send a message, the task that called service call `rcv_mbf` or `trcv_mbf` is placed in the wait queue to receive a message. With service call `prcv_mbf`, error code `E_TMOU`T is immediately returned. The wait queue is managed on FIFO basis.

The `msg` points to a RAM area specified with the `maxmsz` size by service call `cre_mbf`, `icre_mbf`, `acre_mbf`, or `iacre_mbf`.

In service call `trcv_mbf`, parameter `tmout` specifies the timeout time. If a positive value is specified for parameter `tmout`, error code `E_TMOU`T is returned when the `tmout` time has passed without the wait release conditions being satisfied.

If `tmout = TMO_POL` (0) is specified, the same operation as for service call `prcv_mbf` will be performed.

If `tmout = TMO_FEVR` (-1) is specified, timeout monitoring is not performed. In other words, the same operation as for service call `rcv_mbf` will be performed.

If a value larger than 1 is specified for `CFG_TICDENO` (the denominator for time tick cycles), the maximum value that can be specified for `tmout` is `H'7fffffff/CFG_TICDENO`. If a value larger than this is specified, operation is not guaranteed.

For detail of time watch method, refer to section 2.16.4(2), Time Watch Method.

3.12.5 Refer to Message Buffer State (ref_mbf, iref_mbf)

C-Language API:

```
ER ercd = ref_mbf(ID mbfid, T_RMBF *pk_rmbf);
ER ercd = iref_mbf(ID mbfid, T_RMBF *pk_rmbf);
```

Parameters:

ID	mbfid	R4	Message buffer ID
T_RMBF	*pk_rmbf	R5	Pointer to the packet where the message buffer state is to be returned

Return Parameters:

ER	ercd	R0	Normal end (E_OK) or error code
T_RMBF	*pk_rmbf	R5	Pointer to the packet where the message buffer state is stored

Packet Structure:

```
typedef struct t_rmbf{
    ID          stskid;  +0  2  Start task ID of the queue waiting to
                           send a message
    ID          rtskid;  +2  2  Start task ID of the queue waiting to
                           receive a message
    UINT        msgcnt;  +4  4  Number of messages in message buffer
    SIZE        fmbfsz;  +8  4  Size of free buffer (Number of bytes)
}T_RMBF;
```

Error Codes:

E_PAR	[p]	Parameter error (pk_rmbf is other than a multiple of four)
E_ID	[p]	Invalid ID number (mbfid ≤ 0 or mbfid > CFG_MAXMBFID)
E_NOEXS	[k]	Undefined (Message buffer indicated by mbfid does not exist)

Function:

Each service call refers to the state of the message buffer indicated by parameter mbfid and returns the task ID of the task waiting to send a message (stskid), task waiting to receive a message (rtskid), the size of the next message to be received (msgcnt), and the available free buffer size (fmbfsz) to the area indicated by pk_rmbf.

If no task is waiting to receive or send a message, TSK_NONE (0) is returned as a wait task ID.

3.13 Memory Pool Management (Fixed-Size Memory Pool)

Fixed-Size Memory Pool Service Calls: Fixed-size memory pools are controlled by the service calls listed in table 3.41.

Table 3.41 Service Calls for Fixed-Size Memory Pool Control

Service Call ¹	Description	System State ²
		T/E/D/U/L/C
cre_mpf [s]	Creates fixed-size memory pool	T/E/D/U
icre_mpf		N/E/D/U
acre_mpf	Creates fixed-size memory pool and assigns fixed-size memory pool ID automatically	T/E/D/U
iacre_mpf		N/E/D/U
del_mpf	Deletes fixed-size memory pool	T/E/D/U
get_mpf [S]	Acquires fixed-size memory block	T/E/U
pget_mpf [S]	Polls and acquires fixed-size memory block	T/E/D/U
ipget_mpf		N/E/D/U
tget_mpf [S]	Acquires fixed-size memory block with timeout function	T/E/U
rel_mpf [S]	Returns fixed-size memory block	T/E/D/U
irel_mpf		N/E/D/U
ref_mpf	Refers to fixed-size memory pool state	T/E/D/U
iref_mpf		N/E/D/U

- Notes: 1. [S]: Standard profile service calls
[s]: Service calls that are not standard profile service calls but are needed in order to use the standard profile function
2. T: Can be called from task context
N: Can be called from non-task context
E: Can be called from dispatch-enabled state
D: Can be called from dispatch-disabled state
U: Can be called from CPU-unlocked state
L: Can be called from CPU-locked state
C: Can be called from CPU exception handler

Fixed-Size Memory Pool Specifications: The fixed-size memory pool specifications are listed in table 3.42.

Table 3.42 Fixed-Size Memory Pool Specifications

Item	Description
Fixed-size memory pool ID	1 to CFG_MAXMPFID (1023 max.)
Attribute supported	TA_TFIFO: Task wait queue is managed on a FIFO basis TA_TPRI: Task wait queue is managed on priority
Management method	Whether to place kernel management information in the memory pool can be chosen with CFG_MPFMANAGE in the configurator.

3.13.1 Create Fixed-Size Memory Pool**(cre_mpf, icre_mpf)****(acre_mpf, iacre_mpf: Assign Memory Pool ID Automatically)****C-Language API:**

```

ER ercd = cre_mpf(ID mpfid, T_CMPF *pk_cmpf);
ER ercd = icre_mpf(ID mpfid, T_CMPF *pk_cmpf);
ER_ID mpfid = acre_mpf(T_CMPF *pk_cmpf);
ER_ID mpfid = iacre_mpf(T_CMPF *pk_cmpf);

```

Parameters:

<cre_mpf, icre_mpf>				
ID	mpfid	R4	Fixed-size memory pool ID	
T_CMPF	*pk_cmpf	R5	Pointer to the packet where the fixed-size memory pool creation information is stored	
<acre_mpf, iacre_mpf>				
T_CMPF	*pk_cmpf	R4	Pointer to the packet where the fixed-size memory pool creation information is stored	

Return Parameters:

<cre_mpf, icre_mpf>				
ER	ercd	R0	Normal end (E_OK) or error code	
<acre_mpf, iacre_mpf>				
ER_ID	mpfid	R0	Created fixed-size memory pool ID (a positive value) or error code	

Packet Structure:

(1) CFG_MPFMANAGE is not checked

```

typedef struct t_cmpf{
    ATR    mpfatr;  +0  4  Fixed-size memory pool attribute
    UINT   blkcnt;  +4  4  Number of blocks in memory pool
    UINT   blksz;   +8  4  Block size of fixed-size memory pool
                          (Number of bytes)
    VP     mpf;     +12 4  Start address of the fixed-size
                          memory pool area
}T_CMPF;

```

(2) CFG_MPFMANAGE is checked

```

typedef struct t_cmpf{
    ATR    mpfatr;  +0  4  Fixed-size memory pool attribute
    UINT   blkcnt;  +4  4  Number of blocks in memory pool
    UINT   blksz;   +8  4  Block size of fixed-size memory pool
                          (Number of bytes)

```



```

VP      mpf;      +12  4   Start address of the fixed-size
                               memory pool area
VP      mpfmb;    +16  4   Start address of the fixed-size
                               memory pool management table area

```

```
}T_CMPF;
```

Error Codes:

E_NOMEM	[k]	Insufficient memory (Memory pool area cannot be allocated in the memory)
E_RSATR	[p]	Invalid attribute (mpfatr is invalid)
E_PAR	[p]	Parameter error (pk_cmpf is other than a multiple of four, blkcnt = 0, blkksz is other than a multiple of four or blkksz = 0, mpf is other than a multiple of four if mpf is not NULL, or mpfmb is other than a multiple of four (when CFG_MPFMANAGE is checked)
	[k]	TSZ_MPF(blkcnt, blkksz) exceeds 32-bit range)
E_ID	[p]	Invalid ID number (mpfid ≤ 0 or mpfid > CFG_MAXMPFID)
E_OBJ	[k]	Object status is invalid (Fixed-size memory pool indicated by mpfid already exists)
E_NOID	[k]	No ID available

Function:

Service calls `cre_mpf` and `icre_mpf` create a fixed-size memory pool, with an ID indicated by `mpfid`, using the contents specified by `pk_cmpf`.

Service calls `acre_mpf` and `iacre_mpf` search for an unused fixed-size memory pool ID and creates a fixed-size memory pool that has this ID with the contents specified by parameter `pk_cmpf`. The service calls then return the ID as a return parameter. The range to search for an undefined fixed-size memory pool ID is 1 to `CFG_MAXMPFID`.

The queue order waiting to get a memory block as an attribute is specified by `mpfatr` in the following format (table 3.43).

```
mpfatr:= (TA_TFIFO || TA_TPRI)
```

Table 3.43 Fixed-Size Memory Pool Attributes (mpfatr)

mpfatr	Code	Description
TA_TFIFO	H'00000000	Task queue waiting to acquire a memory block is managed on a FIFO basis
TA_TPRI	H'00000001	Task queue waiting to acquire a memory block is managed by priority

Section3 Service Calls

Parameter `blkcnt` specifies the total number of memory blocks to be created.

The size of the memory block to be created is specified by `blksz`, and must be a multiple of four.

When `NULL` is specified as `mpf`, kernel allocates memory pool from fixed-size memory pool area (`CFG_MPF SZ`). After the memory pool has been created, the free fixed-size memory pool area size will decrease by an amount given by the following expression:

(1) `CFG_MPFMANAGE` is not checked

Decrease in size = $(\text{blksz} + 4 \text{ bytes}) \times \text{blkcnt} + 16 \text{ bytes}$

(2) `CFG_MPFMANAGE` is checked

Decrease in size = $\text{blksz} \times \text{blkcnt} + 16 \text{ bytes}$

The memory pool area address allocated by application can be specified as `mpf`. In this case, allocate the memory pool area which size is calculated by `TSZ_MPF(blkcnt, blksz)`, and specify the address as `mpf`. Note, the definition of `TSZ_MPF` is depend on `CFG_MPFMANAGE`.

If the `CFG_MPFMANAGE` is checked, the address for kernel management tables must be specified as `mpfmb`. In this case, allocate the area which size is calculated by `VT SZ_MPFMB(blkcnt, blksz)`, and specify the address as `mpfmb`.

`mpfmb` is a member not specified in the μ ITRON4.0 specification.

Fixed-size memory pools can also be created statically by the configurator.

3.13.2 Delete Fixed-Size Memory Pool (del_mpf)

C-Language API:

```
ER ercd = del_mpf(ID mpfid);
```

Parameters:

ID	mpfid	R4	Fixed-size memory pool ID
----	-------	----	---------------------------

Return Parameters:

ER	ercd	R0	Normal end (E_OK) or error code
----	------	----	---------------------------------

Error Codes:

E_ID	[p]	Invalid ID number (mpfid ≤ 0 or mpfid > CFG_MAXMPFID)
E_NOEXS	[k]	Undefined (Fixed-size memory pool indicated by mpfid does not exist)
E_CTX	[k]	Context error (Called from disabled system state)

Function:

Service call del_mpf deletes the fixed-size memory pool indicated by mpfid.

No error will occur even if there is a task waiting to acquire a memory block in the fixed-size memory pool area indicated by mpfid. However, in that case, the task in the WAITING state will be released and error code E_DLT will be returned.

When the memory pool allocated in the fixed-size memory pool that is created with NULL as mpf is deleted, the free fixed-size memory pool area (CFG_MPFMSZ) will increase by an amount given by the following expression:

- (1) CFG_MPFMANAGE is not checked

Increase in size = (blksz specified at creation) + 4 bytes × blkcnt + 16 bytes

- (2) CFG_MPFMANAGE is checked

Increase in size = (blksz specified at creation) × blkcnt + 16 bytes

The kernel will not perform any processing even when a block has already been acquired.

3.13.3 Get Fixed-Size Memory Block (get_mpf, pget_mpf, ipget_mpf, tget_mpf)

C-Language API:

```
ER ercd = get_mpf(ID mpfid, VP *p_blk);
ER ercd = pget_mpf(ID mpfid, VP *p_blk);
ER ercd = ipget_mpf(ID mpfid, VP *p_blk);
ER ercd = tget_mpf(ID mpfid, VP *p_blk, TMO tmout);
```

Parameters:

ID	mpfid	R4	Fixed-size memory pool ID
VP	*p_blk	R5	Pointer to the area where the start address of the memory block is to be returned
<tget_mpf>			
TMO	tmout	R6	Timeout specification

Return Parameters:

ER	ercd	R0	Normal end (E_OK) or error code
VP	*p_blk	R5	Start address of the area where the start address of the memory block is stored

Error Codes:

E_PAR	[p]	Parameter error (p_blk is other than a multiple of four or tmout ≤ -2)
E_ID	[p]	Invalid ID number (mpfid ≤ 0 or mpfid > CFG_MAXMPFID)
E_NOEXS	[k]	Undefined (Fixed-size memory pool indicated by mpfid does not exist)
E_CTX	[k]	Context error (Called from disabled system state)
E_DLT	[k]	Waiting object deleted (Fixed-size memory pool indicated by mpfid has been deleted)
E_TMOUT	[k]	Polling failed or timeout
E_RLWAI	[k]	WAITING state was forcibly cancelled (rel_wai service call was called in the WAITING state)

Function:

Each service call gets one fixed-size memory block from the fixed-size memory pool indicated by `mpfid`, and returns the start address of the acquired memory block to the area indicated by `p_blk`.

If there are tasks already waiting for the memory pool, or if no task is waiting but there is no memory block available in the fixed-size memory pool, the task having called service call `get_mpf` or `tget_mpf` is placed in the memory acquiring wait queue, and the task having called service call `pget_mpf` or `ipget_mpf` is immediately returned with error code `E_TMOU`. The queue is managed according to the attribute specified at creation.

Parameter `tmout` of service call `tget_mpf` specifies the timeout period. If a positive value is specified for parameter `tmout`, error code `E_TMOU` is returned when the timeout period has passed without the wait release conditions being satisfied.

If `tmout = TMO_POL (0)` is specified, the same operation as for service call `pget_mpf` will be performed.

If `tmout = TMO_FEVR (-1)` is specified, timeout monitoring is not performed. In other words, the same operation as for service call `get_mpf` will be performed.

If a value larger than 1 is specified for `CFG_TICDENO` (the denominator for time tick cycles), the maximum value that can be specified for `tmout` is $H'7fffffff/CFG_TICDENO$. If a value larger than this is specified, operation is not guaranteed.

For detail of time watch method, refer to section 2.16.4(2), Time Watch Method.

3.13.4 Release Fixed-Size Memory Block (rel_mpf, irel_mpf)

C-Language API:

```
ER ercd = rel_mpf(ID mpfid, VP blk);  
ER ercd = irel_mpf(ID mpfid, VP blk);
```

Parameters:

ID	mpfid	R4	Fixed-size memory pool ID
VP	blk	R5	Start address of memory block

Return Parameters:

ER	ercd	R0	Normal end (E_OK) or error code
----	------	----	---------------------------------

Error Codes:

E_PAR	[p]	Parameter error (blk is other than a multiple of four)
	[k]	(Specifies other than the start address of the memory block or returned blk)
E_ID	[p]	Invalid ID number (mpfid ≤ 0 or mpfid > CFG_MAXMPFID)
E_NOEXS	[k]	Undefined (Fixed-size memory pool indicated by mpfid does not exist)

Function:

Each service call returns the memory block indicated by blk to the fixed-size memory pool indicated by mpfid.

The start address of the memory block acquired by service call get_mpf, pget_mpf, ipget_mpf, or tget_mpf must be specified for parameter blk.

If there are tasks waiting to get a memory block in the target fixed-size memory pool, the memory block returned by this service call is passed to the task at the head of the wait queue, releasing it from the WAITING state.

3.13.5 Refer to Fixed-Size Memory Pool State (ref_mpf, iref_mpf)

C-Language API:

```
ER ercd = ref_mpf(ID mpfid, T_RMPF *pk_rmpf);
ER ercd = iref_mpf (ID mpfid, T_RMPF *pk_rmpf);
```

Parameters:

ID	mpfid	R4	Fixed-size memory pool ID
T_RMPF	*pk_rmpf	R5	Pointer to the packet where the fixed-size memory pool state is to be returned

Return Parameters:

ER	ercd	R0	Normal end (E_OK) or error code
T_RMPF	*pk_rmpf	R5	Pointer to the packet where the fixed-size memory pool state is stored

Packet Structure:

```
typedef struct t_rmpf{
    ID      wtskid;  +0  2  Wait task ID
    UINT    fblkcnt; +4  4  Number of blocks of memory space
                               available
}T_RMPF;
```

Error Codes:

E_PAR	[p]	Parameter error (pk_rmpf is other than a multiple of four)
E_ID	[p]	Invalid ID number (mpfid ≤ 0 or mpfid > CFG_MAXMPFID)
E_NOEXS	[k]	Undefined (Fixed-size memory pool indicated by mpfid does not exist)

Function:

Each service call refers to the state of the fixed-size memory pool indicated by mpfid.

Service calls ref_mpf and iref_mpf return the wait task ID (wtskid) and the number of blocks of memory space available (fblkcnt) to the area indicated by pk_rmpf.

If there is no task waiting for the specified memory pool, TSK_NONE (0) is returned as a wait task ID.

3.14 Memory Pool Management (Variable-Size Memory Pool)

Variable-Size Memory Pool Service Calls: Variable-size memory pools are controlled by the service calls listed in table 3.44.

Table 3.44 Service Calls for Variable-Size Memory Pool Control

Service Call ¹	Description	System State ²
		T/N/E/D/U/L/C
cre_mpl	Creates variable-size memory pool	T/E/D/U
icre_mpl		N/E/D/U
acre_mpl	Creates variable-size memory pool and assigns	T/E/D/U
iacre_mpl	variable-size memory pool ID automatically	N/E/D/U
del_mpl	Deletes variable-size memory pool	T/E/D/U
get_mpl	Acquires variable-size memory block	T/E/U
pget_mpl	Polls and acquires variable-size memory block	T/E/D/U
ipget_mpl		N/E/D/U
tget_mpl	Acquires variable-size memory block with timeout function	T/E/U
rel_mpl	Returns variable-size memory block	T/E/D/U
irel_mpl		N/E/D/U
ref_mpl	Refers to variable-size memory pool state	T/E/D/U
iref_mpl		N/E/D/U

- Notes: 1. [S]: Standard profile service calls
 [s]: Service calls that are not standard profile service calls but are needed in order to use the standard profile function
2. T: Can be called from task context
 N: Can be called from non-task context
 E: Can be called from dispatch-enabled state
 D: Can be called from dispatch-disabled state
 U: Can be called from CPU-unlocked state
 L: Can be called from CPU-locked state
 C: Can be called from CPU exception handler

Variable-Size Memory Pool Specifications: The variable-size memory pool specifications are listed in table 3.45.

Table 3.45 Variable-Size Memory Pool Specifications

Item	Description
Variable-size memory pool ID	1 to CFG_MAXMPLID (1023 max.)
Management method	<p>Selecting CFG_NEWMPL through the configurator improves the following.</p> <ul style="list-style-type: none"> • Acquisition and return of memory blocks become faster when a large number of memory blocks are used in the memory pool • The VTA_UNFRAGMENT attribute can be used to reduce fragmentation of free space.
Attributes supported	<p>TA_TFIFO: Task wait queue is managed on a FIFO basis</p> <p>VTA_UNFRAGMENT: Sector management (reducing fragmentation in free space; can be specified only when CFG_NEWMPL is selected)</p>

The free space in the variable-size memory pool may be fragmented. The VTA_UNFRAGMENT reduces this fragmentation. Also refer to section 2.15.2, Controlling Fragmentation of Free Space.

3.14.1 Create Variable-Size Memory Pool**(cre_mpl, icre_mpl)****(acre_mpl, iacre_mpl: Assign Variable-Size Memory Pool ID Automatically)****C-Language API:**

```

ER ercd = cre_mpl(ID mplid, T_CMPL *pk_cmpl);
ER ercd = icre_mpl(ID mplid, T_CMPL *pk_cmpl);
ER_ID mplid = acre_mpl(T_CMPL *pk_cmpl);
ER_ID mplid = iacre_mpl(T_CMPL *pk_cmpl);

```

Parameters:

<cre_mpl, icre_mpl>			
ID	mplid	R4	Variable-size memory pool ID
T_CMPL	*pk_cmpl	R5	Pointer to the packet where the variable-size memory pool creation information is stored
<acre_mpl, iacre_mpl>			
T_CMPL	*pk_cmpl	R4	Pointer to the packet where the variable-size memory pool creation information is stored

Return Parameters:

<cre_mpl, icre_mpl>			
ER	ercd	R0	Normal end (E_OK) or error code
<acre_mpl, iacre_mpl>			
ER_ID	mplid	R4	Created variable-size memory pool ID (a positive value) or error code

Packet Structure:

(1) CFG_NEWMPL is not checked

```

typedef struct t_cmpl{
    ATR    mplatr;  +0  4  Variable-size memory pool attribute
    SIZE   mplsz;  +4  4  Size of memory pool (Number of bytes)
    VP     mpl;    +8  4  Start address of the variable-size
                        memory pool area
}T_CMPL;

```

(2) CFG_NEWMPL is checked

```

typedef struct t_cmpl{
    ATR    mplatr;  +0  4  Variable-size memory pool attribute
    SIZE   mplsz;  +4  4  Size of memory pool (Number of bytes)
    VP     mpl;    +8  4  Start address of the variable-size
                        memory pool area
    VP     mplmb;  +12 4  Start address of the variable-size
                        memory pool management table area
    UINT   minblksz; +16 4  Minimum block size
    UINT   sctnum; +20 4  Maximum sector number
}T_CMPL;

```

Error Codes:

E_NOMEM	[k]	Insufficient memory (Memory pool area cannot be allocated in the memory)
E_RSATR	[p]	Invalid attribute (mplatr is invalid)
E_PAR	[p]	Parameter error (pk_cmpl is other than a multiple of four, mplsiz is other than a multiple of four, mplsiz < TSZ_MPL(1,4), mplsiz ≥ H'80000000, mpl is other than a multiple of four if mpl is not NULL, or while VTA_UNFRAGMENT is selected, minblksz = 0, sctnum = 0, mplsiz < minblksz * 32, or mplmb is other than a multiple of four)
E_ID	[p]	Invalid ID number (mplid ≤ 0 or mplid > CFG_MAXMPLID)
E_OBJ	[k]	Object status is invalid (Variable-size memory pool indicated by mplid already exists)
E_NOID	[k]	No ID available

Function:

Service calls cre_mpl and icre_mpl create a variable-size memory pool with an ID indicated by mplid using the contents specified by pk_cmpl.

Service calls acre_mpl and iacre_mpl search for an unused variable-size memory pool ID and create a variable-size memory pool that has this ID with the contents specified by parameter pk_cmpl, then returns the ID. The range searched for the variable-size memory pool ID is 1 to CFG_MAXMPLID.

(1) mplatr

Specify the logical OR of the following values for mplatr.

(a) Order of tasks in the queue for waiting for memory block acquisition

Only TA_TFIFO can be specified.

- TA_TFIFO (H'00000000): Task queue waiting for memory is managed on a FIFO basis.

(b) Management method

When CFG_NEWMPL is selected, VTA_UNFRAGMENT can be specified.

- VTA_UNFRAGMENT (H'80000000): Sector management (reducing fragmentation in free space)

The VTA_UNFRAGMENT attribute is suitable for a memory pool from which a large number of small memory blocks are to be acquired. When this attribute is specified, small blocks are collectively allocated in specialized contiguous areas to leave larger possible contiguous areas.

Section3 Service Calls

Only when attribute VTA_UNFRAGMENT is specified, mplmb, minblksz, and sctnum become valid. When sctnum is set to a larger value than $\text{mplsz} / (\text{minblksz} \times 32)$, $\text{mplsz} / (\text{minblksz} \times 32)$ is assumed.

For details, refer to section 2.15.2, Controlling Fragmentation of Free Space.

(2) mpsz

Parameter mpsz specifies the size of the variable-size memory pool to be created. Also refer to section 2.15.3, Management of Variable-Size Memory Pool.

The following macro is provided to estimate the approximate size to be specified for mpsz.

`SIZE mpsz = TSZ_MPL(UINT blkcnt, UINT blksz)`

Approximate size (bytes) of a variable-size memory pool area required to hold the blkcnt number of blksz-byte memory blocks

This macro calculates the size assuming that the VTA_UNFRAGMENT is not selected. The equation for calculating the size depends on whether CFG_NEWMPL is selected.

(3) mpl

Parameter mpl specifies the start address of a free area to be used as a variable-size memory pool. The kernel allocates an mpsz-byte area starting from address mpl as a variable-size memory pool.

When NULL is specified as mpl, the kernel allocates an mpsz-byte area from the variable-size memory pool area (CFG_MPLSZ). After the memory pool has been created, the free variable-size memory pool area will decrease by an amount given by the following expression:

Decrease in size = $\text{mplsz} + 16$

(4) mplmb

mplmb is a member not defined in the μ ITRON4.0 specification.

Parameter mplmb is only valid when VTA_UNFRAGMENT is specified; it is ignored in other cases.

Allocate an area for the size calculated by the following macro, and specify the start address of the area as mplmb.

`VTSZ_MPLMB(maximum sector number)`

(5) minblksz and sctnum

These are parameters not defined in the μ ITRON4.0 specification.

These parameters are valid only when VTA_UNFRAGMENT is specified. For details, refer to the above description of attribute VTA_UNFRAGMENT.

Variable-size memory pools can also be created statically by the configurator.

Supplement:

The standard alignment size for the address of a memory block is 4. To specify an address with the cache line size (16 or 32), allocate the area as follows (N means the alignment size).

- (1) When CFG_NEWMPL is selected and VTA_UNFRAGMENT is not specified
 - Allocate a memory pool area to the N-byte boundary address, and specify that address when creating a memory pool.
 - Specify a multiple of N as the size of every memory block to be acquired.
- (2) When CFG_NEWMPL is selected and VTA_UNFRAGMENT is specified
 - Allocate a memory pool area to the N-byte boundary address, and specify that address when creating a memory pool.
 - Specify N for the minimum block size.
 - Specify a multiple of N as the size of every memory block to be acquired.
- (3) When CFG_NEWMPL is not selected
 1. Alignment when N = 16
 - Allocate a memory pool area to the 16-byte boundary address, and specify that address when creating a memory pool.
 - Specify a multiple of 16 as the size of every memory block to be acquired.
 2. Alignment when N = 32
 - Allocate a memory pool area to the address obtained by (32-byte boundary address - 16) by the application, and specify that address when creating a memory pool.
 - Specify (a multiple of N + 16) as the size of every memory block to be acquired.

3.14.2 Delete Variable-Size Memory Pool (del_mpl)

C-Language API:

```
ER ercd = del_mpl(ID mplid);
```

Parameters:

ID	mplid	R4	Variable-size memory pool ID
----	-------	----	------------------------------

Return Parameters:

ER	ercd	R0	Normal end (E_OK) or error code
----	------	----	---------------------------------

Error Codes:

E_ID	[p]	Invalid ID number (mplid ≤ 0 or mplid > CFG_MAXMPLID)
E_NOEXS	[k]	Undefined (Variable-size memory pool indicated by mplid does not exist)
E_CTX	[k]	Context error (Called from disabled system state)

Function:

Service call del_mpl deletes the variable-size memory pool indicated by mplid. No error will occur even if there is a task waiting to acquire a memory block in the variable-size memory pool area. However, in that case, the task in the WAITING state will be released and error code E_DLT will be returned.

When the memory pool is allocated in the variable-size memory pool that is created with NULL as mpl is deleted, the free variable-size memory pool area (CFG_MPLSZ) will increase by an amount given by the following expression:

$$\text{Increase in size} = (\text{mplsz specified at creation}) + 16 \text{ bytes}$$

The kernel will not perform any processing even when a block has already been acquired.

3.14.3 Get Variable-Size Memory Block (get_mpl, pget_mpl, ipget_mpl, tget_mpl)

C-Language API:

```
ER ercd = get_mpl (ID mplid, UINT blkksz, VP *p_blk);
ER ercd = pget_mpl (ID mplid, UINT blkksz, VP *p_blk);
ER ercd = ipget_mpl (ID mplid, UINT blkksz, VP *p_blk);
ER ercd = tget_mpl (ID mplid, UINT blkksz, VP *p_blk);
```

Parameters:

ID	mplid	R4	Variable-size memory pool ID
UINT	blkksz	R5	Memory block size (Number of bytes)
VP	*p_blk	R6	Pointer to the area where the start address of the memory block is to be returned
 <tget_mpl>			
TMO	tmout	R7	Timeout specification

Return Parameters:

ER	ercd	R0	Normal end (E_OK) or error code
VP	*p_blk	R6	Pointer to the area where the start address of the memory block is stored

Error Codes:

E_PAR	[p]	Parameter error (p_blk is other than a multiple of four, blkksz is other than a multiple of four or 0, or tmout ≤ -2)
	[k]	(mplsz - 16 < blkksz)
E_ID	[p]	Invalid ID number (mplid ≤ 0 or mplid > CFG_MAXMPLID)
E_NOEXS	[k]	Undefined (Variable-size memory pool indicated by mplid does not exist)
E_CTX	[k]	Context error (Called from disabled system state)
E_DLT	[k]	Waiting object deleted (The memory pool specified by mplid has been deleted)
E_TMOUT	[k]	Polling failed or timeout
E_RLWAI	[k]	WAITING state was forcibly cancelled (rel_wai service call was called in the WAITING state)

Note: mplsz: Memory pool size created at variable-size memory pool creation

Function:

Each service call acquires a variable-size memory block with the size specified by `blksz` (number of bytes) from the variable-size memory pool indicated by `mplid`, and returns the start address of the acquired memory block to the area indicated by `p_blk`.

After the memory block has been acquired, the size of the variable-size memory pool free space will decrease. For details, refer to section 2.15.3, Management of Variable-Size Memory Pool.

If there are tasks already waiting for the memory pool, or if no task is waiting but there is no memory block available, the task having called service call `get_mpl` or `tget_mpl` is placed in the memory block wait queue, and the task having called service call `pget_mpl` or `ipget_mpl` is immediately terminated with the error code `E_TMOU` returned. The queue is managed on a first-in first-out (FIFO) basis.

Parameter `tmout` of service call `tget_mpl` specifies the timeout period. If a positive value is specified for parameter `tmout`, error code `E_TMOU` is returned when the timeout period has passed without the wait release conditions being satisfied.

If `tmout = TMO_POL (0)` is specified, the same operation as for service call `pget_mpl` will be performed.

If `tmout = TMO_FEVR (-1)` is specified, timeout watch is not performed. In other words, the same operation as for service call `get_mpl` will be performed.

If a value larger than 1 is specified for `CFG_TICDENO` (the denominator for time tick cycles), the maximum value that can be specified for `tmout` is `H'7fffffff/CFG_TICDENO`. If a value larger than this is specified, operation is not guaranteed.

For detail of time watch method, refer to section 2.16.4(2), Time Watch Method.

3.14.4 Release Variable-Size Memory Block (rel_mpl, irel_mpl)

C-Language API:

```
ER ercd = rel_mpl(ID mplid, VP blk);
ER ercd = irel_mpl(ID mplid, VP blk);
```

Parameters:

ID	mplid	R4	Variable-size memory pool ID
VP	blk	R5	Start address of memory block

Return Parameters:

ER	ercd	R0	Normal end (E_OK) or error code
----	------	----	---------------------------------

Error Codes:

E_PAR	[p]	Parameter error (blk is other than a multiple of four)
	[k]	(blk is other than the memory block start address or blk has already been returned)
E_ID	[p]	Invalid ID number (mplid ≤ 0 or mplid > CFG_MAXMPLID)
E_NOEXS	[k]	Undefined (Variable-size memory pool indicated by mplid does not exist)

Function:

Each service call returns the memory block specified by blk to the variable-size memory pool specified by mplid.

The start address of the memory block acquired by service call get_mpl, pget_mpl, ipget_mpl, or tget_mpl must be specified as parameter blk.

After the memory block has been returned, the size of the variable-size memory pool free space will increase. For details, refer to section 2.15.3, Management of Variable-Size Memory Pool.

When the target variable-size memory pool has a contiguous memory block requested by the task at the head of the memory block acquisition wait queue, the memory block is assigned to that task; as a result, the task is released from the WAITING state.

The same process will be done for the remaining tasks in the order of the wait queue if the remaining memory pool size still has enough contiguous memory blocks available.

3.14.5 Refer to Variable-Size Memory Pool State (ref_mpl, iref_mpl)

C-Language API:

```
ER ercd = ref_mpl (ID mplid, T_RMPL *pk_rmpl);  
ER ercd = iref_mpl (ID mplid, T_RMPL *pk_rmpl);
```

Parameters:

ID	mplid	R4	Variable-size memory pool ID
T_RMPL	*pk_rmpl	R5	Pointer to the packet where the variable-size memory pool state is to be returned

Return Parameters:

ER	ercd	R0	Normal end (E_OK) or error code
T_RMPL	*pk_rmpl	R5	Pointer to the packet where the variable-size memory pool state is stored

Packet Structure:

```
typedef struct t_rmpl{  
    ID      wtskid;  +0  2  Wait task ID  
    SIZE    fmplsz;  +4  4  Total size of available memory area  
                                (Number of bytes)  
    UINT    fblksz;  +8  4  Maximum memory area available (Number  
                                of bytes)  
}T_RMPL;
```

Error Codes:

E_PAR	[p]	Parameter error (pk_rmpl is other than a multiple of four)
E_ID	[p]	Invalid ID number (mplid ≤ 0 or mplid > CFG_MAXMPLID)
E_NOEXS	[k]	Undefined (Variable-size memory pool indicated by mplid does not exist)

Function:

Each service call refers to the status of the variable-size memory pool indicated by mpid and returns the wait task ID (wtskid), the current free memory area total size (fmplsz), and the maximum free memory space size (fblksz) to the area indicated by pk_rmpl.

The free space is usually fragmented. The maximum contiguous free space is returned to parameter fblksz. The block up to the size fblksz can be acquired immediately by calling service call get_mpl, pget_mpl, ipget_mpl, or tget_mpl.

If there is no task waiting to get a memory block, TSK_NONE (0) is returned as a wait task ID.

3.15 Time Management (System Clock)

System Clock Management Service Calls: System clock is controlled by the service calls listed in table 3.46.

Table 3.46 Service Calls for System Clock Management

Service Call ¹	Description	System State ²
		T/N/E/D/U/L/C
set_tim [S]	Sets system clock	T/E/D/U
iset_tim		N/E/D/U
get_tim [S]	Gets system clock	T/E/D/U
iget_tim		N/E/D/U
isig_tim [S]	Supplies time tick	Automatically executed according to CFG_TIMUSE check

- Notes: 1. [S]: Standard profile service calls
 [s]: Service calls that are not standard profile service calls but are needed in order to use the standard profile function
2. T: Can be called from task context
 N: Can be called from non-task context
 E: Can be called from dispatch-enabled state
 D: Can be called from dispatch-disabled state
 U: Can be called from CPU-unlocked state
 L: Can be called from CPU-locked state
 C: Can be called from CPU exception handler

System Clock Management Specifications: The system clock management specifications are listed in table 3.47.

Table 3.47 System Clock Management Specifications

Item	Description
System clock value	Unsigned 48 bits
System clock unit	1 ms
System clock update cycle	CFG_TICNUME/CFG_TICDENO [ms]*
System clock initial value (at initialization)	H'000000000000

Note: The values of TIC_NUME and TIC_DENO defined in kernel_macro.h are same as the values of CFG_TICNUME and CFG_TICDENO, respectively.

Section3 Service Calls

The system clock is expressed as 48-bit unsigned integer value by using the data type “SYSTIM”. The maximum value of the system clock is shown as follows.

[Case of “CFG_TICNUME/CFG_TICDENO ≤ 1”]

Maximum value = H'7fffffffff/CFG_TICDENO

[Case of “CFG_TICNUME/CFG_TICDENO > 1”]

Maximum value = H'7fffffffff

When the system clock exceeds the above maximum value at timer interrupt (isig_tim), the system clock is initialized to 0.

If a value larger than the above maximum value is specified in the set_tim service call, the system operation is not guaranteed.

3.15.1 Set System Clock (set_tim, iset_tim)**C-Language API:**

```
ER ercd = set_tim (SYSTIM *p_system);
ER ercd = iset_tim (SYSTIM *p_system);
```

Parameters:

SYSTIM	*p_system	R4	Pointer to the packet where the current time data is indicated
--------	-----------	----	----------------------------------------------------------------

Return Parameters:

ER	ercd	R0	Normal end (E_OK) or error code
----	------	----	---------------------------------

Packet Structure:

```
typedef struct systim {
    UH    utime;    0    2    Current time data (upper)
    UW    ltime;    +4   4    Current time data (lower)
}SYSTIM;
```

Error Codes:

E_PAR	[p]	Parameter error (p_system is other than a multiple of four)
-------	-----	-------------------------------------------------------------

Function:

Each service call changes the current system clock retained in the system to a value specified by p_system.

If a value larger than 1 is specified for CFG_TICDENO (the denominator for time tick cycles), the maximum value that can be specified for tmout is H'7fffffff/CFG_TICDENO. If a value larger than this is specified, operation is not guaranteed.

For detail of time watch method, refer to section 2.16.4(2), Time Watch Method.

3.15.2 Get System Clock (get_tim, iget_tim)

C-Language API:

```
ER ercd = get_tim (SYSTIM *p_system);  
ER ercd = iget_tim (SYSTIM *p_system);
```

Parameters:

SYSTIM	*p_system	R4	Start address of the packet where the current time data is to be returned
--------	-----------	----	---------------------------------------------------------------------------

Return Parameters:

ER	ercd	R0	Normal end (E_OK) or error code
SYSTIM	*p_system	R4	Start address of the packet where the current time data is stored

Packet Structure:

```
typedef struct system {  
    UH    utime;    0    2    Current time data (upper)  
    UW    ltime;    +4   4    Current time data (lower)  
}SYSTIM;
```

Error Codes:

E_PAR	[p]	Parameter error (p_system is other than a multiple of four)
-------	-----	-------------------------------------------------------------

Function:

Each service call reads the current system clock and returns it to the area indicated by p_system.

3.15.3 Supply Time Tick (isig_tim)

Function:

Updates the system clock.

When CFG_TIMUSE is selected, the system is configured such that service call isig_tim is executed automatically in cycles equal to CFG_TICDENO/CFG_TICNUME [ms]. That is, this function is not a service call, and so cannot be called from an application.

When a time tick is supplied, the kernel performs the following time-related processing.

- (1) System clock update (+1)
- (2) Startup of time event handler
- (3) Timeout processing for tasks in a WAITING state due to service calls with a timeout, such as tslp_tsk

In order to use kernel functions related to time, the timer driver must be included. For details, refer to Appendix D, Timer Driver.

3.16 Time Management (Cyclic Handler)

Cyclic Handler Service Calls: Cyclic handler is controlled by the service calls listed in table 3.48.

Table 3.48 Service Calls for Cyclic Handler

Service Call ¹	Description	System State ²
		T/N/E/D/U/L/C
cre_cyc [s]	Creates cyclic handler	T/E/D/U
icre_cyc		N/E/D/U
acre_cyc	Creates cyclic handler and assigns cyclic handler ID automatically	T/E/D/U
iacre_cyc		N/E/D/U
del_cyc	Deletes cyclic handler	T/E/D/U
sta_cyc [S]	Starts cyclic handler operation	T/E/D/U
ista_cyc		N/E/D/U
stp_cyc [S]	Stops cyclic handler operation	T/E/D/U
istp_cyc		N/E/D/U
ref_cyc	Refers to the cyclic handler state	T/E/D/U
iref_cyc		N/E/D/U

- Notes: 1. [S]: Standard profile service calls
 [s]: Service calls that are not standard profile service calls but are needed in order to use the standard profile function
2. T: Can be called from task context
 N: Can be called from non-task context
 E: Can be called from dispatch-enabled state
 D: Can be called from dispatch-disabled state
 U: Can be called from CPU-unlocked state
 L: Can be called from CPU-locked state
 C: Can be called from CPU exception handler

Cyclic Handler Specifications: The cyclic handler specifications are listed in table 3.49.

Table 3.49 Cyclic Handler Specifications

Item	Description
Cyclic handler ID	1 to CFG_MAXCYCID (14 max.)
Attribute supported	TA_HLNG: The task is written in a high-level language TA_ASM: The task is written in assembly language TA_STA: Starts cyclic handler operation TA_PHS: Reserves initiation phase

3.16.1 Create Cyclic Handler**(cre_cyc, icre_cyc)****(acre_cyc, iacre_cyc: Assign Cyclic Handler ID Automatically)****C-Language API:**

```

ER ercd = cre_cyc (ID cycid, T_CCYC *pk_ccyc);
ER ercd = icre_cyc (ID cycid, T_CCYC *pk_ccyc);
ER_ID cycid = acre_cyc (T_CCYC *pk_ccyc);
ER_ID cycid = iacre_cyc (T_CCYC *pk_ccyc);

```

Parameters:

```

<cre_cyc, icre_cyc>
ID          cycid      R4    Cyclic handler ID
T_CCYC     *pk_ccyc   R5    Pointer to the packet where the cyclic
      handler creation information is stored

<acre_cyc, iacre_cyc>
T_CCYC     *pk_ccyc   R4    Pointer to the packet where the cyclic
      handler creation information is stored

```

Return Parameters:

```

<cre_cyc, icre_cyc>
ER          ercd      R0    Normal end (E_OK) or error code

<acre_cyc, iacre_cyc>
HNO        cycid     R0    Created cyclic handler ID number (a
      positive value) or error code

```

Packet Structure:

```

typedef struct t_ccyc{
      ATR      cycatr;  0    4    Cyclic handler attribute
      VP_INT   exinf;   +4   4    Extended information
      FP       cychr;   +8   4    Cyclic handler address
      RELTIM   cyctim; +12  4    Cyclic handler initiation cycle
      RELTIM   cycphs; +16  4    Cyclic handler initiation phase
}T_CCYC;

```

Error Codes:

```

E_RSATR [p] Invalid attribute (cycatr is invalid)
E_PAR   [p] Parameter error (pk_ccyc is other than a multiple of four,
      cyctim = 0, cycphs > cyctim, or cychr is an odd address)
E_ID    [p] Invalid ID number (cycid ≤ 0 or cycid > CFG_MAXCYCID)
E_OBJ   [k] Object status is invalid
      (Cyclic handler indicated by cycid already exists)
E_NOID  [k] No ID available

```

Function:

Service calls `cre_cyc` and `icre_cyc` create the cyclic handler indicated by parameter `cycid` with the contents specified by parameter `pk_ccyc`.

Service calls `acre_cyc` and `iacre_cyc` search for an unused cyclic handler ID and define a cyclic handler that has the searched ID with the contents specified by parameter `pk_ccyc`, and return the defined cyclic handler ID as a return parameter. The range for searching for an unused cyclic handler specification number is 1 to `CFG_MAXCYCID`.

The cyclic handler is a time event handler for the non-task context initiated by the time interval.

Parameter `cycatr` is specified in the following format. See table 3.50 for details.

$$\text{cycatr} = ((\text{TA_HLNG} \parallel \text{TA_ASM}) \mid [\text{TA_STA}] \mid [\text{TA_PHS}])$$

Table 3.50 Cyclic Handler Attributes (`cycatr`)

cycatr	Code	Description
TA_HLNG	H'00000000	The handler is written in a high-level language
TA_ASM	H'00000001	The handler is written in assembly language
TA_STA	H'00000002	Starts the cyclic handler operation
TA_PHS	H'00000004	Reserves initiation phase

When `TA_STA` is specified, the cyclic handler is set to the operating state after it is created.

When `TA_STA` is not specified, the cyclic handler does not operate until service calls `sta_cyc` or `ista_cyc` is called. When `TA_PHS` is specified, the initiation phase of the cyclic handler is kept before activating the cyclic handler, and the next time to initiate the handler is determined.

When `TA_PHS` is not specified, the next time to initiate the cyclic handler is determined based on the time that service calls `sta_cyc` or `ista_cyc` is called.

Parameter `exinf` specifies the extended information to be passed as a parameter when initiating the cyclic handler. Parameter `exinf` can be widely used by the user, for example, to set information concerning cyclic handlers to be defined.

Parameter `cychdr` specifies the start address of the cyclic handler.

Parameter `cyctim` specifies the handler initiation state.

Parameter `cycphs` specifies the handler initiation phase.

If a value larger than 1 is specified for `CFG_TICDENO` (the denominator for time tick cycles), the maximum value that can be specified for `cyctim` and `cycphs` is $H'7\text{ffffff}/\text{CFG_TICDENO}$. If a value larger than this is specified, operation is not guaranteed.

For detail of time watch method, refer to section 2.16.4(2), Time Watch Method.

The first time to initiate the cyclic handler occurs after cycphs (initiation phase) has passed since the service call that creates the cyclic handler has been called. The cyclic handler is then initiated at every cyctim (initiation interval).

The cyclic handler can also be created statically by the configurator.

3.16.2 Delete Cyclic Handler (del_cyc)

C-Language API:

```
ER ercd = del_cyc (ID cycid);
```

Parameters:

ID	cycid	R4	Cyclic handler ID
----	-------	----	-------------------

Return Parameters:

ER	ercd	R0	Normal end (E_OK) or error code
----	------	----	---------------------------------

Error Codes:

E_ID	[p]	Invalid ID number (cycid ≤ 0 or cycid > CFG_MAXCYCID)
E_NOEXS	[k]	Undefined (Cyclic handler indicated by cycid does not exist)
E_CTX	[k]	Context error (Called from disabled system state)

Function:

Service call del_cyc deletes the cyclic handler indicated by parameter cycid.

3.16.3 Start Cyclic Handler (sta_cyc, ista_cyc)

C-Language API:

```
ER ercd = sta_cyc (ID cycid);  
ER ercd = ista_cyc (ID cycid);
```

Parameters:

ID	cycid	R4	Cyclic handler ID
----	-------	----	-------------------

Return Parameters:

ER	ercd	R0	Normal end (E_OK) or error code
----	------	----	---------------------------------

Error Codes:

E_ID	[p]	Invalid ID number (cycid ≤ 0 or cycid > CFG_MAXCYCID)
E_NOEXS	[k]	Undefined (Cyclic handler specified by cycid does not exist)

Function:

Each service call causes the cycle handler specified by cycid to enter the operation state.

If TA_PHS is not specified as a cyclic handler attribute, the cyclic handler is started each time the start cycle has passed, based on the timing at which the service calls are called.

If the cyclic handler specified by cycid is in the operating state and TA_PHS is not specified as its attribute, the next timing of initiation is set after the service call is called.

If the cyclic handler specified by cycid is in the operating state and TA_PHS is specified as its attribute, the next timing of initiation is not set.

3.16.4 Stop Cyclic Handler (stp_cyc, istp_cyc)

C-Language API:

```
ER ercd = stp_cyc (ID cycid);  
ER ercd = istp_cyc (ID cycid);
```

Parameters:

ID	cycid	R4	Cyclic handler ID
----	-------	----	-------------------

Return Parameters:

ER	ercd	R0	Normal end (E_OK) or error code
----	------	----	---------------------------------

Error Codes:

E_ID	[p]	Invalid ID number (cycid ≤ 0 or cycid > CFG_MAXCYCID)
E_NOEXS	[k]	Undefined (Cyclic handler specified by cycid does not exist)

Function:

Each service call causes the cyclic handler indicated by parameter cycid to enter the not-operating state.

3.16.5 Refer to Cyclic Handler State (ref_cyc, iref_cyc)

C-Language API:

```
ER ercd = ref_cyc (ID cycid, T_RCYC *pk_rcyc);
ER ercd = iref_cyc (ID cycid, T_RCYC *pk_rcyc);
```

Parameters:

ID	cycid	R4	Cyclic handler ID
T_RCYC	*pk_rcyc	R5	Pointer to the packet where the cyclic handler state is to be returned

Return Parameters:

ER	ercd	R0	Normal end (E_OK) or error code
T_RCYC	*pk_rcyc	R5	Pointer to the packet where the cyclic handler state is stored

Packet Structure:

```
typedef struct t_rcyc{
    STAT      cycstat; +0  4  Cyclic handler operating state
    RELTIM    lefttim ; +4  4  Remaining time until the cyclic
                                handler is initiated
}T_RCYC;
```

Error Codes:

E_PAR	[p]	Parameter error (pk_rcyc is other than a multiple of four)
E_ID	[p]	Invalid ID number (cycid ≤ 0 or cycid > CFG_MAXCYCID)
E_NOEXS	[k]	Undefined (Cyclic handler specified by cycid does not exist)

Function:

Each service call reads the cyclic handler state indicated by cycid and returns the cyclic handler operation state (cycstat) and the time remaining until the cyclic handler is initiated (lefttim), to the area indicated by parameter pk_rcyc.

The target cyclic handler operation state is returned to parameter cycstat.

Table 3.51 Handler Initiation State (cycstat)

cycstat	Code	Description
TCYC_STP	H'00000000	The cyclic handler is not in the operating state
TCYC_STA	H'00000001	The cyclic handler is in the operating state

The relative time until the target cyclic handler is next initiated is returned to parameter lefttim. When the target cyclic handler is not initiated, lefttim is undefined.

3.17 Time Management (Alarm Handler)

Alarm Handler Service Calls: Alarm handler is controlled by the service calls listed in table 3.52.

Table 3.52 Service Calls for Alarm Handler

Service Call ¹	Description	System State ²
		T/N/E/D/U/L/C
cre_alm	Creates alarm handler	T/E/D/U
icre_alm		N/E/D/U
acre_alm	Creates alarm handler and assigns alarm handler ID automatically	T/E/D/U
iacre_alm		N/E/D/U
del_alm	Deletes alarm handler	T/E/D/U
sta_alm	Starts alarm handler operation	T/E/D/U
ista_alm		N/E/D/U
stp_alm	Stops alarm handler operation	T/E/D/U
istp_alm		N/E/D/U
ref_alm	Refers to the alarm handler state	T/E/D/U
iref_alm		N/E/D/U

- Notes: 1. [S]: Standard profile service calls
 [s]: Service calls that are not standard profile service calls but are needed in order to use the standard profile function
2. T: Can be called from task context
 N: Can be called from non-task context
 E: Can be called from dispatch-enabled state
 D: Can be called from dispatch-disabled state
 U: Can be called from CPU-unlocked state
 L: Can be called from CPU-locked state
 C: Can be called from CPU exception handler

Alarm Handler Specifications: The alarm handler specifications are listed in table 3.53.

Table 3.53 Alarm Handler Specifications

Item	Description
Alarm handler ID	1 to CFG_MAXALMID (15 max)
Attribute supported	TA_HLNG: The task is written in a high-level language TA_ASM: The task is written in assembly language

3.17.1 Create Alarm Handler

(cre_alm, icre_alm)

(acre_alm, iacre_alm: Assign Alarm Handler ID Automatically)

C-Language API:

```
ER ercd = cre_alm (ID almid, T_CALM *pk_calm);
ER ercd = icre_alm (ID almid, T_CALM *pk_calm);
ER_ID almid = acre_alm (T_CALM *pk_calm);
ER_ID almid = iacre_alm (T_CALM *pk_calm);
```

Parameters:

```
<cre_alm, icre_alm>
ID          almid      R4    Alarm handler ID
T_CALM     *pk_calm   R5    Pointer to the packet where the alarm
      handler creation information is stored

<acre_alm, iacre_alm>
T_CALM     *pk_calm   R4    Pointer to the packet where the alarm
      handler creation information is stored
```

Return Parameters:

```
<cre_alm, icre_alm>
ER          ercd       R0    Normal end (E_OK) or error code

<acre_alm, iacre_alm>
ER_ID      almid      R0    Created alarm handler ID (a positive
      value) or error code
```

Packet Structure:

```
typedef      struct      t_calm {
              ATR        almatr;  0    4    Alarm handler attribute
              VP_INT     exinf;   +4   4    Extended information
              FP         almhdr;  +8   4    Alarm handler address
}T_CALM;
```

Error Codes:

```
E_RSATR [p] Invalid attribute (almatr is invalid)
E_PAR [p] Parameter error (pk_calm is other than a multiple of four or
almhdr is an odd value)
E_ID [p] Invalid ID number (almid ≤ 0 or almid > CFG_MAXALMID)
E_OBJ [k] Object status is invalid
      (Alarm handler indicated by almid already exists)
E_NOID [k] No ID available
```

Function:

Service calls `cre_alm` and `icre_alm` create the alarm handler indicated by parameter `almid` with the contents specified by parameter `pk_calm`.

Service calls `acre_alm` and `iacre_alm` search for an unused alarm handler ID and define an alarm handler that has the searched ID with the contents specified by parameter `pk_calm`, and return the defined alarm handler ID as a return parameter. The range for searching for an unused alarm handler ID is 1 to `CFG_MAXALMID`.

The alarm handler is a time event handler for the non-task context initiated at the specified time only once.

Parameter `almatr` is specified in the following format. See table 3.54 for details.

`almatr:= (TA_HLNG || TA_ASM)`

Table 3.54 Alarm Handler Attributes (almatr)

almatr	Code	Description
TA_HLNG	H'00000000	The handler is written in a high-level language
TA_ASM	H'00000001	The handler is written in assembly language

Parameter `exinf` specifies extended information to be returned as a parameter when initiating the alarm handler. Parameter `exinf` can be widely used by the user, for example, to set information concerning alarm handlers to be defined.

Parameter `almhdr` specifies the start address of the alarm handler.

The time to initiate the alarm handler is not set immediately after creating the alarm handler. The alarm handler is in the stop state.

The alarm handler can also be created statically by the configurator.

3.17.2 Delete Alarm Handler (del_alm)

C-Language API:

```
ER ercd = del_alm (ID almid);
```

Parameters:

ID	almid	R4	Alarm handler ID
----	-------	----	------------------

Return Parameters:

ER	ercd	R0	Normal end (E_OK) or error code
----	------	----	---------------------------------

Error Codes:

E_ID	[p]	Invalid ID number (almid \leq 0 or almid $>$ CFG_MAXALMID)
E_NOEXS	[k]	Undefined (Alarm handler specified by almid does not exist)
E_CTX	[k]	Context error (Called from disabled system state)

Function:

Service call del_alm deletes the alarm handler indicated by parameter almid.

3.17.3 Start Alarm Handler (sta_alm, ista_alm)

C-Language API:

```
ER ercd = sta_alm (ID almid, RELTIM almtim);
```

```
ER ercd = ista_alm (ID almid, RELTIM almtim);
```

Parameters:

ID	almid	R4	Alarm handler ID
RELTIM	almtim	R5	Alarm handler initiation time

Return Parameters:

ER	ercd	R0	Normal end (E_OK) or error code
----	------	----	---------------------------------

Error Codes:

E_ID	[p]	Invalid ID number (almid \leq 0 or almid > CFG_MAXALMID)
E_NOEXS	[k]	Undefined (Alarm handler specified by almid does not exist)

Function:

The starting time for the alarm handler specified by almid is set to the relative time specified by almtim after the moment at which the service call is called, to start operation of the alarm handler.

If a time is set for an alarm handler already in operation, the previous starting time setting is cancelled, and the new starting time is set.

If almtim is set to 0, the alarm handler is started at the next time tick.

When a value larger than 1 is specified for CFG_TICDENO (the denominator for time tick cycles), the maximum value that can be specified for almtim is $H'ffffff/CFG_TICDENO$. If a value larger than this is specified, operation is not guaranteed.

For detail of time watch method, refer to section 2.16.4(2), Time Watch Method.

3.17.4 Stop Alarm Handler (stp_alm, istp_alm)

C-Language API:

```
ER ercd = stp_alm (ID almid);  
ER ercd = istp_alm (ID almid);
```

Parameters:

ID	almid	R4	Alarm handler ID
----	-------	----	------------------

Return Parameters:

ER	ercd	R0	Normal end (E_OK) or error code
----	------	----	---------------------------------

Error Codes:

E_ID	[p]	Invalid ID number (almid \leq 0 or almid $>$ CFG_MAXALMID)
E_NOEXS	[k]	Undefined (Alarm handler specified by almid does not exist)

Function:

Each service call releases the alarm handler initiation time indicated by parameter almid, and stops alarm handler operation.

3.17.5 Refer to Alarm Handler State (ref_alm, iref_alm)

C-Language API:

```
ER ercd = ref_alm (ID almid, T_RALM *pk_ralm);
ER ercd = iref_alm (ID almid, T_RALM *pk_ralm);
```

Parameters:

ID	almid	R4	Alarm handler ID
T_RALM	*pk_ralm	R5	Pointer to the packet where the alarm handler state is to be returned

Return Parameters:

ER	ercd	R0	Normal end (E_OK) or error code
T_RALM	*pk_ralm	R5	Pointer to the packet where the alarm handler state is stored

Packet Structure:

```
typedef struct t_ralm{
    STAT    almstat;    +0  4    Alarm handler operation state
    RELTIM  lefttim;    +4  4    Remaining time until the alarm
                                handler is initiated
}T_RALM;
```

Error Codes:

E_PAR	[p]	Parameter error (pk_ralm is other than a multiple of four)
E_ID	[p]	Invalid ID number (almid ≤ 0 or almid > CFG_MAXALMID)
E_NOEXS	[k]	Undefined (Alarm handler specified by almid does not exist)

Function:

Each service call reads the alarm handler state indicated by almid and returns the alarm handler operating state (almstat) and remaining time until the alarm handler is initiated (lefttim) to the area indicated by parameter pk_ralm.

The target alarm handler activation state is returned to parameter almstat.

Table 3.55 Alarm Handler State (almstat)

almstat	Code	Description
TALM_STP	H'00000000	The alarm handler is not operating
TALM_STA	H'00000001	The alarm handler is operating

Relative time until the target alarm handler is initiated next is returned to parameter lefttim. When the target alarm handler is not initiated, lefttim is undefined.

3.18 Time Management (Overrun Handler)

Overrun Handler Service Calls: Overrun handler is controlled by the service calls listed in table 3.56.

Table 3.56 Service Calls for Overrun Handler

Service Call ¹	Description	System State ²
		T/N/E/D/U/L/C
def_ovr	Defines overrun handler	T/E/D/U
sta_ovr	Starts overrun handler operation	T/E/D/U
ista_ovr		N/E/D/U
stp_ovr	Stops overrun handler operation	T/E/D/U
istp_ovr		N/E/D/U
ref_ovr	Refers to overrun handler state	T/E/D/U
iref_ovr		N/E/D/U

- Notes: 1. [S]: Standard profile service calls
 [s]: Service calls that are not standard profile service calls but are needed in order to use the standard profile function
2. T: Can be called from task context
 N: Can be called from non-task context
 E: Can be called from dispatch-enabled state
 D: Can be called from dispatch-disabled state
 U: Can be called from CPU-unlocked state
 L: Can be called from CPU-locked state
 C: Can be called from CPU exception handler

Only one overrun handler can be defined in the system. The overrun handler is a time event handler.

The processor time used by the task includes the execution times of a task, the service calls called by the task, and the interrupt handler that is initiated during execution of the task. Used processor time is not counted while the task is not in the RUNNING state.

Overrun Handler Specifications: The overrun handler specifications are listed in table 3.57.

Table 3.57 Overrun Handler Specifications

Item	Description
Processor time unit (OVRTIM)	Same as system clock (1 [ms])
Attribute supported	TA_HLNG: The task is written in a high-level language TA_ASM: The task is written in assembly language

3.18.1 Define Overrun Handler (def_ovr)

C-Language API:

```
ER ercd = def_ovr (T_DOVR *pk_dovr);
```

Parameters:

T_DOVR	*pk_dovr	R4	Pointer to the packet where the overrun handler definition information is stored
--------	----------	----	----------------------------------------------------------------------------------

Return Parameters:

ER	ercd	R0	Normal end (E_OK) or error code
----	------	----	---------------------------------

Packet Structure:

```
typedef struct t_dovr {
    ATR  ovratr;    0   4   Overrun handler attribute
    FP   ovrhdr;   +4  4   Overrun handler address
}T_DOVR;
```

Error Codes:

E_RSATR	[p]	Invalid attribute (ovratr is invalid)
E_PAR	[p]	Parameter error (pk_dovr is other than a multiple of four or ovrhdr is an odd value)

Function:

The overrun handler is defined using the content specified by pk_dovr.

The overrun handler is a time event handler for non-task contexts which is started when the processor is used by a task for a time exceeding a preset time.

Parameter ovratr is specified in the following format. See table 3.58 for details.

```
ovratr := (TA_HLNG || TA_ASM)
```

Table 3.58 Overrun Handler Attributes (ovratr)

ovratr	Code	Description
TA_HLNG	H'00000000	The handler is written in a high-level language
TA_ASM	H'00000001	The handler is written in assembly language

As ovrhdr, the start address of the overrun handler is specified.

When, in service call def_ovr, pk_dovr = NULL(0) is specified, the overrun handler definition is cancelled.

When an overrun handler has already been defined, if this service call is called, the preceding definition is cancelled and the new definition takes its place.

An overrun handler can also be defined statically by the configurator.

3.18.2 Start Overrun Handler (sta_ovr, ista_ovr)

C-Language API:

```
ER ercd = sta_ovr (ID tskid, OVRTIM ovrtime);
```

```
ER ercd = ista_ovr (ID tskid, OVRTIM ovrtime);
```

Parameters:

ID	tskid	R4	Task ID
OVRTIM	ovrtim	R5	Upper processor time limit

Return Parameters:

ER	ercd	R0	Normal end (E_OK) or error code
----	------	----	---------------------------------

Error Codes:

E_ID	[p]	Invalid ID number (tskid < 0, tskid > CFG_MAXTSKID, or tskid = TSK_SELF(0) is specified in a non-task context)
E_NOEXS	[k]	Undefined (Task specified by tskid does not exist)
E_OBJ	[k]	Object status is invalid (Overrun handler has not been defined)

Function:

Overrun handler operation begins for the task specified by tskid.

By specifying tskid = TSK_SELF(0), the current task can be specified.

The upper processor time limit for the task is set to the time specified by ovrtime, and the processor time used is cleared to 0. If upper processor time has been already specified for the task indicated by tskid, the upper processor time limit previously specified is cancelled, and the new processor time limit is set.

When the processor time used exceeds the upper processor time limit, the overrun handler is started.

When a value larger than 1 is specified for CFG_TICDENO (the denominator for time tick cycles), the maximum value that can be specified for ovrtime is $H'ffffff/CFG_TICDENO$. If a value larger than this is specified, operation is not guaranteed.

If 0 is specified for ovrtime, the overrun handler is started on the first time tick after the task begins to use the processor.

For detail of time watch method, refer to section 2.16.4(2), Time Watch Method.

3.18.3 Stop Overrun Handler Operation (stp_ovr, istp_ovr)

C-Language API:

```
ER ercd = stp_ovr (ID tskid);
ER ercd = istp_ovr (ID tskid);
```

Parameters:

ID	tskid	R4	Task ID
----	-------	----	---------

Return Parameters:

ER	ercd	R0	Normal end (E_OK) or error code
----	------	----	---------------------------------

Error Codes:

E_ID	[p]	Invalid ID number (tskid < 0, tskid > CFG_MAXTSKID, or tskid = TSK_SELF(0) is specified in a non-task context)
E_NOEXS	[k]	Undefined (Task specified by tskid does not exist)
E_OBJ	[k]	Object status is invalid (Overrun handler has not been defined)

Function:

Each service call releases the upper processor time limit for the task indicated by parameter tskid and stops overrun handler operation.

By specifying tskid = TSK_SELF (0), the current task can be specified.

3.18.4 Refer to Overrun Handler State (ref_ovr, iref_ovr)**C-Language API:**

```
ER ercd = ref_ovr (ID tskid, T_ROVR *pk_rovr);
ER ercd = iref_ovr (ID tskid, T_ROVR *pk_rovr);
```

Parameters:

ID	tskid	R4	Task ID
T_ROVR	*pk_rovr	R5	Pointer to the packet where the overrun handler state is to be returned

Return Parameters:

ER	ercd	R0	Normal end (E_OK) or error code
T_ROVR	*pk_rovr	R5	Pointer to the packet where the overrun handler state is stored

Packet Structure:

```
typedef struct t_rovr {
    STAT ovrstat; +0 4  Overrun handler operation state
    OVRTIM leftotm; +4 4  Remaining processor time
}T_ROVR;
```

Error Codes:

E_PAR	[p]	Parameter error (pk_rovr is other than a multiple of four)
E_ID	[p]	Invalid ID number (tskid < 0 , tskid > CFG_MAXTSKID, or tskid = TSK_SELF(0) is specified in a non-task context)
E_NOEXS	[k]	Undefined (Task specified by tskid does not exist)
E_OBJ	[k]	Object status is invalid (Overrun handler has not been defined)

Function:

The state of the overrun handler for the task specified by tskid is referenced, and the state of operation of the overrun handler (ovrstat) and the remaining processor time (leftotm) are returned to the area specified by pk_rovr.

By specifying tskid = TSK_SELF (0), the current task can be specified.

As the operating state of the overrun handler, the upper processor time limit setting is returned as ovrstat.

Table 3.59 Handler Activation State (ovrstat)

ovrstat	Code	Description
TOVR_STP	H'00000000	No upper processor time limit is set
TOVR_STA	H'00000001	An upper processor time limit is set

The processor time remaining until the overrun handler is started due to the target task is returned as leftotm. If no upper processor time limit is set for the task, the value of leftotm is undefined.

3.19 System State Management

System State Management Service Calls: System state is controlled by the service calls listed in table 3.60.

Table 3.60 Service Calls for System State Management

Service Call ¹	Description	System State ²
		T/E/D/U/L/C
rot_rdq	[S] Rotates ready queue	T/E/D/U
irotd_rdq	[S]	N/E/D/U
get_tid	[S] Refers to task ID in RUNNING state	T/E/D/U/C
iget_tid	[S]	N/E/D/U/C
loc_cpu	[S] Locks CPU	T/E/D/U/L
iloc_cpu	[S]	N/E/D/U/L
unl_cpu	[S] Unlocks CPU	T/E/D/U/L
iunl_cpu	[S]	N/E/D/U/L
dis_dsp	[S] Disables task dispatch	T/E/D/U
ena_dsp	[S] Enables task dispatch	T/E/D/U
sns_ctx	[S] Refers to task context	T/N/E/D/U/L/C
sns_loc	[S] Refers to CPU-locked state	T/N/E/D/U/L/C
sns_dsp	[S] Refers to dispatch-disabled state	T/N/E/D/U/L/C
sns_dpn	[S] Refers to dispatch-pended state	T/N/E/D/U/L/C
vsta_knl	[s] Starts kernel	T/N/E/D/U/L/C
ivsta_knl	[s]	T/N/E/D/U/L/C
vsys_dwn	[s] Terminates the system	T/N/E/D/U/L/C
ivsys_dwn	[s]	T/N/E/D/U/L/C
vget_trc	Acquires trace	T/E/D/U
ivget_trc		N/E/D/U
ivbgn_int	Acquires start of interrupt handler to trace	N/E/D/U
ivend_int	Acquires end of interrupt handler to trace	N/E/D/U

Notes: 1. [S]: Standard profile service calls
 [s]: Service calls that are not standard profile service calls but are needed in order to use the standard profile function

- 2. T: Can be called from task context
- N: Can be called from non-task context
- E: Can be called from dispatch-enabled state
- D: Can be called from dispatch-disabled state
- U: Can be called from CPU-unlocked state
- L: Can be called from CPU-locked state
- C: Can be called from CPU exception handler

3.19.1 Rotate Ready Queue (rot_rdq, irot_rdq)

C-Language API:

```
ER ercd = rot_rdq(PRI tskpri);  
ER ercd = irot_rdq(PRI tskpri);
```

Parameters:

PRI	tskpri	R4	Task priority
-----	--------	----	---------------

Return Parameters:

ER	ercd	R0	Normal end (E_OK) or error code
----	------	----	---------------------------------

Error Codes:

E_PAR	[p]	Parameter error (tskpri < 0, tskpri > CFG_MAXTSKPRI, or tskpri = TPRI_SELF(0) is specified in a non-task context)
-------	-----	-------------------------------------------------------------------------------------------------------------------

Function:

Each service call rotates the ready queue of the task priority indicated by parameter tskpri. In other words, the task at the head of the task priority ready queue is sent to the end of the queue, enabling the second task in the ready queue to be executed.

Specifying tskpri = TPRI_SELF (0) rotates the ready queue with the base priority of the current task. The base priority is the same as the current priority when the mutex function is not used; however, the current priority is not the same as the base priority while the mutex is locked. Thus, the ready queue with current priority, including the current task, cannot be rotated even when TPRI_SELF is specified.

3.19.2 Get Task ID in RUNNING State (get_tid, iget_tid)

C-Language API:

```
ER ercd = get_tid(ID *p_tskid);  
ER ercd = iget_tid(ID *p_tskid);
```

Parameters:

ID	*p_tskid	R4	Pointer to the area where the task ID is to be returned
----	----------	----	---------------------------------------------------------

Return Parameters:

ER	ercd	R0	Normal end (E_OK) or error code
ID	*p_tskid	R4	Pointer to the task ID

Error Codes:

E_PAR	[p]	Parameter error (p_tskid is an odd value)
-------	-----	-------------------------------------------

Function:

Each service call gets the task ID in the RUNNING state and returns it to the area indicated by p_tskid. If each service call is called from task context, the current task ID is returned. If each service call is called from non-task context, the task ID that is being executed is returned. If there is no task in the RUNNING state, TSK_NONE (0) is returned.

Service calls get_tid and iget_tid can also be called from the CPU exception handler.

3.19.3 Lock CPU (loc_cpu, iloc_cpu)

C-Language API:

```
ER ercd = loc_cpu(void);  
ER ercd = iloc_cpu(void);
```

Parameters:

None

Return Parameters:

ER ercd R0 Normal end (E_OK)

Error Codes:

None

Function:

Each service call locks the CPU and inhibits interrupts and task dispatches.

The following describes the CPU-locked state:

- Tasks cannot be scheduled while the CPU is locked.
- Interrupts, having a level equal to or below the kernel interrupt mask level (CFG_KNLMSKLVL) defined by the configurator, are inhibited.
- Only the following service calls can be called from the CPU-locked state. The system operation cannot be guaranteed when a service call other than the following is called:

- ext_tsk
- exd_tsk
- sns_tex
- loc_cpu, iloc_cpu
- unl_cpu, iunl_cpu
- sns_ctx
- sns_loc
- sns_dsp
- sns_dpn
- vsta_knl, ivsta_knl
- vsys_dwn, ivsys_dwn

When the following service calls are called in the CPU locked state, the system returns to the CPU unlocked state.

- unl_cpu or iunl_cpu
- ext_tsk or exd_tsk

The transition between CPU-Locked state and CPU-unlocked state is occurred only when `loc_cpu`, `iloc_cpu`, `unl_cpu`, `iunl_cpu`, `ext_tsk`, or `exd_tsk` service call is called. An interrupt handler which level is equal or lower than the kernel interrupt mask level (`CFG_KNLMSKLVL`), time event handler, initialization routine, and task exception routine must unlock the CPU at termination. If the CPU is locked at termination, normal system operation cannot be guaranteed. Note, the CPU at the start of these handlers is unlocked. If the CPU exception handler changes CPU-locked/unlocked state, the handler must return to former state. If the handler does not return to former state, normal system operation cannot be guaranteed.

If service calls `loc_cpu` and `iloc_cpu` are called while the CPU is locked, no error will occur. In this case, queuing will not be done.

3.19.4 Unlock CPU (unl_cpu, iunl_cpu)

C-Language API:

```
ER ercd = unl_cpu(void);  
ER ercd = iunl_cpu(void);
```

Parameters:

None

Return Parameters:

ER ercd R0 Normal end (E_OK)

Error Codes:

None

Function:

Each service call unlocks the CPU, which was locked by service call loc_cpu or iloc_cpu. If the CPU enters the task-context dispatch-enabled state by the service call, the task scheduling is performed.

When the system makes a transition to the CPU-locked state by calling service call iloc_cpu in the interrupt handler, service call iunl_cpu must be called to unlock the CPU before returning from the interrupt handler.

The CPU-locked state and dispatch-disabled state are managed individually. Thus, service call unl_cpu or iunl_cpu does not enable the task dispatch by calling service call ena_dsp.

If service calls unl_cpu and iunl_cpu are called in CPU-unlocked state, no error will occur, but queuing will not be done.

3.19.5 Disable Dispatch (dis_dsp)

C-Language API:

```
ER ercd = dis_dsp(void);
```

Parameters:

None

Return Parameters:

ER ercd R0 Normal end (E_OK)

Error Codes:

None

Function:

Service call dis_dsp disables task dispatch.

The following describes the dispatch-disabled state:

- Task scheduling is delayed, so that a task other than the current task cannot enter the RUNNING state.
- Interrupts can be accepted.
- Service calls to shift a task to the WAITING state cannot be called.

When the following service calls are called while task dispatch is disabled, the system returns to the task dispatch-enabled state.

- ena_dsp
- ext_tsk or exd_tsk

The transition between dispatch-disabled state and dispatch-enabled state is occurred only when dis_dsp, ena_dsp, ext_tsk, or exd_tsk service call is called.

If the CPU exception handler changes dispatch-disabled/enabled state, the handler must return to former state. If the handler does not return to former state, normal system operation cannot be guaranteed.

When task dispatch is disabled, the task state is undefined. Therefore, if the current task refers to its state by calling service call ref_tsk, the returned state is not always the RUNNING state.

An error will not occur when service call dis_dsp is called while the task dispatch is disabled; however, queuing will not be done.

3.19.6 Enable Dispatch (ena_dsp)

C-Language API:

```
ER ercd = ena_dsp(void);
```

Parameters:

None

Return Parameters:

ER ercd R0 Normal end (E_OK)

Error Codes:

None

Function:

Service call ena_dsp enables task dispatch disabled by service call dis_dsp. Task scheduling is then performed after the service call.

An error will not occur when service call ena_dsp is called during task dispatch-enabled state; however, queuing will not be done.

3.19.7 Refer to Context (sns_ctx)**C-Language API:**

```
BOOL state = sns_ctx(void);
```

Parameters:

None

Return Parameters:

BOOL state R0 Context

Function:

TRUE is returned when service call sns_ctx is called from non-task context. FALSE is returned when service call sns_ctx is called from task context.

Service call sns_ctx can be called in the CPU-locked state and from the CPU exception handler.

3.19.8 Refer to CPU-Locked State (sns_loc)

C-Language API:

```
BOOL state = sns_loc(void);
```

Parameters:

None

Return Parameters:

BOOL state R0 CPU-locked state

Function:

Service call sns_loc returns TRUE when the CPU is locked. Service call sns_loc returns FALSE when the CPU is unlocked.

Service call sns_loc can be called in the CPU-locked state and from the CPU exception handler.

3.19.9 Refer to Dispatch-disabled State (sns_dsp)

C-Language API:

```
BOOL state = sns_dsp(void);
```

Parameters:

None

Return Parameters:

BOOL state R0 Dispatch-disabled state

Function:

Service call sns_dsp returns TRUE when task dispatch is disabled. Service call sns_dsp returns FALSE when task dispatch is enabled.

Service call sns_dsp can be called in the CPU-locked state and from the CPU exception handler.

3.19.10 Refer to Dispatch-Pended State (sns_dpn)

C-Language API:

```
BOOL state = sns_dpn(void);
```

Parameters:

None

Return Parameters:

BOOL state R0 Dispatch-pended state

Function:

Service call `sns_dpn` returns TRUE when the task dispatch is pended. Otherwise, service call `sns_dpn` returns FALSE.

When the following conditions are satisfied, FALSE is returned. Otherwise, TRUE is returned.

- Task dispatch is not disabled.
- The CPU is unlocked.
- Task or task exception processing routine
- An interrupt is not masked by service call `chg_ims`.

Service call `sns_dpn` can be called in the CPU-locked state and from the CPU exception handler.

3.19.11 Start Kernel (vsta_knl, ivsta_knl)

C-Language API:

```
void vsta_knl(void);  
void ivsta_knl(void);
```

Assembler API:

```
Branches to symbol "__kernel_reset"
```

Parameters:

None

Return Parameters:

Service call vsta_knl does not return any parameters to the current task.

Function:

Service call vsta_knl starts the kernel.

If the kernel has already been started, the multitasking environment up to that point is all nullified.

This service call can also be called in the CPU-locked state and from the CPU exception handler. It can also be called before the kernel is started.

This service call should be called in a state with all interrupts masked (SR.IMASK = 15).

In the HI7700/4 and HI7750/4, this service call can also be called from an exception block state (SR.BL = 1).

An application calling this service call must be linked with the kernel. Refer to 2.18.1, Resetting the CPU and Initiating the Kernel.

This service call is a function original to the HI7000/4 series.

3.19.12 System Down (vsys_dwn, ivsys_dwn)

C-Language API:

```
void vsys_dwn (W type, ER ercd, VW inf1, VW inf2);  
void ivsys_dwn (W type, ER ercd, VW inf1, VW inf2);
```

Parameters:

W	type	R4	Error type
ER	ercd	R5	Error code
VW	inf1	R6	System abnormal information 1
VW	inf2	R7	System abnormal information 2

Return Parameters:

Service call vsys_dwn is not returned.

Function:

Service call vsys_dwn passes control to the system down routine.

A value (1 to H'7fffffff) corresponding to the error type must be specified for the parameter type. Values below 0 are reserved for future expansion.

The system down routine is also executed when abnormal operation is detected in the kernel.

Service call vsys_dwn can be called in the CPU-locked state and from the CPU exception handler.

This service call can be called even in the exception block state (SR.BL = 1) in the HI7700/4 and HI7750/4.

This service call is a function original to the HI7000/4 series.

3.19.13 Acquire Trace Information (vget_trc, ivget_trc)

C-Language API:

```
ER ercd = vget_trc(VW para1, VW para2, VW para3, VW para4);  
ER ercd = ivget_trc(VW para1, VW para2, VW para3, VW para4);
```

Parameters:

VW	para1	R4	Parameter 1
VW	para2	R5	Parameter 2
VW	para3	R6	Parameter 3
VW	para4	R7	Parameter 4

Return Parameters:

ER	ercd	R0	Normal end (E_OK)
----	------	----	-------------------

Error Codes:

None

Function:

A trace of information required by the user is obtained.

The parameters para1 to para4 can be used freely by the user to distinguish the information to be acquired.

The acquired trace information can be shown by using a debugging extension (DX).

If CFG_TRACE is not checked by the configurator, this service call does not perform any processing.

This service call is a function original to the HI7000/4 series.

3.19.14 Acquire Start of Interrupt Handler as Trace Information (ivbgn_int)

C-Language API:

```
ER ercd = ivbgn_int(UINT dintno);
```

Parameters:

UINT	dintno	R4	Interrupt handler number
------	--------	----	--------------------------

Return Parameters:

ER	ercd	R0	Normal end (E_OK)
----	------	----	-------------------

Error Codes:

None

Function:

The beginning of processing of the interrupt handler for the interrupt handler number specified by dintno is traced.

The interrupt handler number is, for the HI7000/4, the CPU vector number, and for the HI7700/4 and HI7750/4 is the CPU exception code (in the case of a CPU for which INTEVT2 exists, the INTEVT2 code; otherwise, the INTEVT code).

This service call should be called at the beginning of an interrupt handler. In addition, it should always be used in combination with ivend_int.

An error does not result if it is called from code other than an interrupt handler, but in such cases there is the possibility that the debugging extension trace display may be illegal.

If CFG_TRACE is not checked by the configurator, this service call does not perform any processing.

This service call is a function original to the HI7000/4 series.

3.19.15 Acquire End of Interrupt Handler as Trace Information (ivend_int)

C-Language API:

```
ER ercd = ivend_int(UINT dintno);
```

Parameters:

UINT	dintno	R4	Interrupt handler number
------	--------	----	--------------------------

Return Parameters:

ER	ercd	R0	Normal end (E_OK)
----	------	----	-------------------

Error Codes:

None

Function:

The end of processing of the interrupt handler for the interrupt handler number specified by dintno is traced.

The interrupt handler number is, for the HI7000/4, the CPU vector number, and for the HI7700/4 and HI7750/4 is the CPU exception code (in the case of a CPU for which INTEVT2 exists, the INTEVT2 code; otherwise, the INTEVT code).

This service call should be called at the end of an interrupt handler. In addition, it should always be used in combination with ivbgn_int.

An error does not result if it is called from code other than an interrupt handler, but in such cases there is the possibility that the debugging extension trace display may be illegal.

If CFG_TRACE is not checked by the configurator, this service call does not perform any processing.

This service call is a function original to the HI7000/4 series.

3.20 Interrupt Management

Interrupt Management Service Calls: Interrupts are controlled by the service calls listed in table 3.61.

Table 3.61 Service Calls for Interrupt Management

Service Call ¹	Description	System State ²
		T/N/E/D/U/L/C
def_inh	Defines interrupt handler	T/E/D/U
idef_inh		N/E/D/U
chg_ims	Changes interrupt mask	T/E/D/U
ichg_ims		N/E/D/U
get_ims	Refers to interrupt mask	T/E/D/U
iget_ims		N/E/D/U

Notes: 1. [S]: Standard profile service calls
 [s]: Service calls that are not standard profile service calls but are needed in order to use the standard profile function

2. T: Can be called from task context
 N: Can be called from non-task context
 E: Can be called from dispatch-enabled state
 D: Can be called from dispatch-disabled state
 U: Can be called from CPU-unlocked state
 L: Can be called from CPU-locked state
 C: Can be called from CPU exception handler

Interrupt Management Specifications: The interrupt management specifications are listed in table 3.62.

Table 3.62 Interrupt Management Specifications

Item	Description
Interrupt handler number	0 to CFG_MAXVCTNO (511 max.) (HI7000/4) 0 to CFG_MAXVCTNO (H'fe0 max.) (HI7700/4, HI7750/4)
Attribute supported	TA_HLNG: The task is written in a high-level language TA_ASM: The task is written in assembly language

3.20.1 Define Interrupt Handler (def_inh, ideo_inh)

C-Language API:

```
ER ercd = def_inh(INHNO inhno, T_DINH *pk_dinh);
ER ercd = ideo_inh(INHNO inhno, T_DINH *pk_dinh);
```

Parameters:

INHNO	inhno	R4	Interrupt handler number
T_DINH	*pk_dinh	R5	Pointer to the packet where the definition information of interrupt handler is stored

Return Parameters:

ER	ercd	R0	Normal end (E_OK) or error code
----	------	----	---------------------------------

Packet Structure:

```
typedef struct t_dinh
{
  ATR   inhatr;   0   4   Handler attribute
  FP    inhdr;   +4  4   Handler address
  UINT  inhsr;   +8  4   SR at initiation (ignored in the
                          HI7000/4)
}T_DINH;
```

Correction: Please read inhdr for inhdr.

Error Codes:

E_RSATR	[p]	Invalid attribute (inhatr is invalid)
E_PAR	[p]	Parameter error (pk_dinh is other than a multiple of four or inhdr is an odd value)

HI7000/4:
Invalid number specification
(inhno = 25 or 26, or inhno > CFG_MAXVCTNO)

HI7700/4, HI7750/4:
Invalid number specification (inhno has a value other than a multiple of H'20, inhno = H'160, or inhno > CFG_MAXVCTNO)

Function:

The handler for the interrupt handler number specified by inhno is defined as the content specified by pk_dinh.

The interrupt handler number is, for the HI7000/4, the CPU vector number, and for the HI7700/4 and HI7750/4 is the CPU exception code (in the case of a CPU for which INTEVT2 exists, the INTEVT2 code; otherwise, the INTEVT code).

On the HI7000/4, this call cannot be used to define handlers for the interrupt handler numbers 0 to 3 (power-on reset, manual reset). (If these numbers are specified, the call is ignored.)

On the HI7700/4 and HI7750/4, this call cannot be used to define handlers for the interrupt handler numbers 0 and H'20 (power-on, manual reset). (If these numbers are specified, the call is ignored.)

The parameter `inhatr` is specified in the following format. See table 3.63 for details.

$$\text{inhatr} := (\text{TA_HLNG} \parallel \text{TA_ASM})$$

Table 3.63 Interrupt Handler Attributes (inhatr)

inhatr	Code	Description
TA_HLNG	H'00000000	The handler is written in a high-level language
TA_ASM	H'00000001	The handler is written in assembly language
VTA_DIRECT	H'80000000	Direct interrupt handler (HI7000/4 only)
VTA_REGBANK	H'40000000	Normal interrupt handler making use of the register banks (HI7000/4 only)

In the case of the HI7000/4, VTA_DIRECT can be specified to indicate that the handler is to be a direct interrupt handler. If you intend to define an interrupt handler with an interrupt level higher than the kernel interrupt mask level (CFG_KNLMSKLVL), VTA_DIRECT must be specified. However, the VTA_DIRECT attribute cannot be specified for CPU exceptions or trap interrupt handler numbers. When CFG_DIRECT is selected for the configurator, it is not possible to define handlers without the VTA_DIRECT attribute. If this is attempted, the HI7000/4 returns the error E_RSATR.

VTA_REGBANK is valid with the HI7000/4. Furthermore, the selected CPU core must be the SH-2A or SH2A-FPU and [SELECT] must have been selected for CFG_REGBANK on the [Interrupt/CPU Exception Handler] page in the configurator. When all of these conditions hold, specify VTA_REGBANK when defining normal interrupt handlers for interrupts with which the register banks are to be used. In other cases, the specification of VTA_REGBANK has no meaning. If VTA_DIRECT has already been specified, the specification of VTA_REGBANK is superfluous and is simply ignored.

Be sure to specify VTA_REGBANK whenever you define a normal interrupt handler for an interrupt with priority level `xx` for which the corresponding CFG_BANKLVL`xx` (`xx` is a value from 01 to 15, which indicates an interrupt level) checkbox is marked. When you define a normal interrupt handler for an interrupt with priority level `xx` for which CFG_BANKLVL`xx` has not been marked, do not specify VTA_REGBANK.

Specification of VTA_REGBANK only has meaning when the interrupt handler number is 14, 64, or a higher number. This is simply the range of interrupt handler numbers for which register banks can be used, and does not apply to the NMI or UBC interrupts. The specification of VTA_REGBANK for an interrupt handler number outside this range has no meaning and is simply ignored.

If the selected CPU core is not the SH-2A or SH2A-FPU or you have selected an option other than [SELECT] for CFG_REGBANK in the configurator, handling by the HI7000/4 is as follows.

- When the CPU core is the SH-2A or SH2A-FPU and [ALL] is selected for CFG_REGBANK:
Register banks are used for interrupts with interrupt handler numbers 14, 64, and higher numbers. Register banks are not used with other interrupts (i.e., the NMI and UBC interrupts).
- When the CPU core is not the SH-2A or SH2A-FPU, or [NOTUSE] or [NOBANK] is selected for CFG_REGBANK:
The register banks are not used with any interrupt.

On the HI7700/4 and HI7750/4, inhsr sets the value of the status register (SR) on startup of the interrupt handler inhsr is specified using the same bit position as the SR configuration. A value equal to or greater than the interrupt level should always be specified as the interrupt mask bit. If a value lower than the interrupt level is specified, system operation may be abnormal. For information of SR register, see section 4.2.1, SR Register and section 4.2.2, Cache Lock Function (SH-3, SH3-DSP).

On actual interrupt handler start, SR is as follows.

- Interrupt mask bit
As specified by inhsr.
- Bits other than the interrupt mask bit
As specified by inhsr

In the HI7000/4, inhsr has no meaning, and is simply ignored. The actual value of SR on startup is determined by the CPU interrupt processing.

When pk_dinh = NULL (0) is specified, the definition of inhno is cancelled.

inhsr is a member not defined in the μ ITRON4.0 specification.

3.20.2 Change Interrupt Mask (chg_ims, ichg_ims)

C-Language API:

```
ER ercd = chg_ims(IMASK imask);  
ER ercd = ichg_ims(IMASK imask);
```

Parameters:

IMASK	imask	R4	Interrupt mask value
-------	-------	----	----------------------

Return Parameters:

ER	ercd	R0	Normal end (E_OK) or error code
----	------	----	---------------------------------

Error Codes:

E_PAR	[p]	Parameter error (A value other than SR_IMS00 to SR_IMS15 was specified for imask)
-------	-----	-----------------------------------------------------------------------------------

Function:

Each service call changes the current interrupt mask to the level specified by imask.

The imask can be specified as follows:

- SR_IMSnn (H'0000000m) Changes interrupt mask level to nn.
nn: Character string indicating two-digit decimal number from 0 to 15 (00, 01, 02, ..., 15).
m: nn converted to hexadecimal number.

Use the service calls when changing the interrupt mask level in the following cases. The SR can be directly changed when changing the interrupt mask level in cases other than below.

1. When the interrupt mask level is changed from level 0 to a level other than 0 in a task context.
2. When the interrupt mask level is returned to 0 after the above case.

Otherwise, normal system operation cannot be guaranteed.

Note that service calls must not be called while the interrupt mask level is made higher than the kernel interrupt mask level (CFG_KNLMSKLV) unless this service call is used to lower the interrupt mask level to a level equal to or below the kernel interrupt mask level. Otherwise, normal system operation cannot be guaranteed.

If an interrupt is masked from the task context, the task is regarded as the non-task context until the interrupt mask level is returned to 0.

For information of SR register, see section 4.2.1, SR Register.

3.20.3 Refer to Interrupt Mask (get_ims, iget_ims)

C-Language API:

```
ER ercd = get_ims(IMASK *p_ims);
ER ercd = iget_ims(IMASK *p_ims);
```

Parameters:

IMASK	*p_ims	R4	Start address of the area where the interrupt mask level is to be returned
-------	--------	----	----------------------------------------------------------------------------

Return Parameters:

ER	ercd	R0	Normal end (E_OK) or error code
IMASK	*p_ims	R4	Start address of the area where the interrupt mask level is stored

Error Codes:

E_PAR	[p]	Parameter error (p_ims is other than a multiple of four)
-------	-----	----------------------------------------------------------

Function:

Each service call refers to the interrupt mask bits (IMASK bits) of the current CPU status register (SR) and returns the interrupt mask level to the area indicated by p_ims.

The value to be returned to p_ims has the same format as the parameter imask used by the service call chg_ims.

3.21 Service Call Management

Service Call Management Service Calls: Service call is controlled by the service calls listed in table 3.64.

Table 3.64 Service Calls for Service Call Management

Service Call ¹	Description	System State ²
		T/N/E/D/U/L/C
def_svc	Defines extended service call	T/E/D/U
idef_svc		N/E/D/U
cal_svc	Calls service call	T/E/D/U
ical_svc		N/E/D/U

- Notes:
- [S]: Standard profile service calls
[s]: Service calls that are not standard profile service calls but are needed in order to use the standard profile function
 - T: Can be called from task context
N: Can be called from non-task context
E: Can be called from dispatch-enabled state
D: Can be called from dispatch-disabled state
U: Can be called from CPU-unlocked state
L: Can be called from CPU-locked state
C: Can be called from CPU exception handler

Service Call Management Specifications: The service call management specifications are listed in table 3.65.

Table 3.65 Service Call Management Specifications

Item	Description
Function code of extended service call	1 to CFG_MAXSVCCD (1023 max.)
Parameter that can be passed	0 to four VP_INT type parameters
Attribute supported	TA_HLNG: The task is written in a high-level language TA_ASM: The task is written in assembly language

3.21.1 Define Extended Service Call (def_svc, idef_svc)

C-Language API:

```
ER ercd = def_svc (FN fncd, T_DSVC *pk_dsvc);
ER ercd = idef_svc (FN fncd, T_DSVC *pk_dsvc);
```

Parameters:

FN	fncd	R4	Function code of extended service call
T_DSVC	*pk_dsvc	R5	Start address of the extended service call routine definition information

Return Parameters:

ER	ercd	R0	Normal end (E_OK) or error code
----	------	----	---------------------------------

Packet Structure:

```
typedef struct t_dsvc {
    ATR   svcatr;    0  4  Extended service call routine attribute
    FP   svcrtn;   +4  4  Extended service call routine address
} T_DSVC;
```

Error Codes:

E_RSATR	[p]	Invalid attribute (svcatr is invalid)
E_PAR	[p]	Parameter error (pk_dsvc is other than a multiple of four, svcrtn is an odd address, fncd ≤ 0, or fncd > CFG_MAXSVCCD)

Function:

The service calls `def_svc` and `idef_svc` define an extended service call routine for the extended function code indicated by `fncd` with the contents specified by `pk_dsvc`.

The parameter `svcatr` is specified in the following format. See table 3.66 for details.

```
svcatr = ((TA_HLNG || TA_ASM))
```

Table 3.66 Extended Service Routine Attributes (svcatr)

svcatr	Code	Description
TA_HLNG	H'00000000	The extended service call routine is written in a high-level language
TA_ASM	H'00000001	The extended service call routine is written in assembly language

The parameter `svcrtn` specifies the start address of the extended service call routine.

If `pk_dsvc = NULL (0)` is specified for `svcatr` in the service call `def_svc`, the extended service call routine defined for `fncd` is cancelled.

The state of calling task is taken over in extended service call routines.

3.21.2 Call Service Call (cal_svc, ical_svc)

C-Language API:

```
ER_UINT ercd = cal_svc (FN fncd, ...);  
ER_UINT ercd = ical_svc (FN fncd, ...);
```

Parameters:

FN	fncd	@R15	Function code of extended service call
----	------	------	----------------------------------------

In "..." above, up to four VP_INT-type parameters can be substituted. If more than four parameters are specified, only the first four parameters are passed to the extended service call routine.

VP_INT	par1	@(4,R15)	Parameter 1
VP_INT	par2	@(8,R15)	Parameter 2
VP_INT	par3	@(12,R15)	Parameter 3
VP_INT	par4	@(16,R15)	Parameter 4

Return Parameters:

ER_UINT	ercd	R0	Return value from service call
---------	------	----	--------------------------------

Error Codes:

E_RSFN	[p]	Reserved function code (fncd is invalid or cannot be used)
--------	-----	------------------------------------------------------------

Function:

Each service call executes the extended service call routine corresponding to the function code specified by the parameter fncd.

Up to four VP_INT-type parameters can be specified. In the extended service call routine to be called, par1 to par4 are stored in R4 to R7, respectively, and passed.

For details, refer to section 4.7, Extended Service Call Routines.

3.22 System Configuration Management

System Configuration Management Service Calls: System configurations are controlled by the service calls listed in table 3.67.

Table 3.67 Service Calls for System Configuration Management

Service Call ¹	Description	System State ²
		T/N/E/D/U/L/C
def_exc	Defines CPU exception handler	T/E/D/U
idef_exc		N/E/D/U
vdef_trp	Defines CPU exception handler (TRAPA	T/E/D/U
ivdef_trp	instruction exception)	N/E/D/U
ref_cfg	Refers to configuration information	T/E/D/U
iref_cfg		N/E/D/U
ref_ver	Refers to version information	T/E/D/U
iref_ver		N/E/D/U

- Notes: 1. [S]: Standard profile service calls
 [s]: Service calls that are not standard profile service calls but are needed in order to use the standard profile function
2. T: Can be called from task context
 N: Can be called from non-task context
 E: Can be called from dispatch-enabled state
 D: Can be called from dispatch-disabled state
 U: Can be called from CPU-unlocked state
 L: Can be called from CPU-locked state
 C: Can be called from CPU exception handler

System Configuration Management Specifications: The system configuration management specifications are listed in table 3.68.

Table 3.68 System Configuration Management Specifications

Item	Description
CPU exception handler number	0 to CFG_MAXVCTNO (511 max.) (HI7000/4) 0 to CFG_MAXVCTNO (H'fe0 max.) (HI7700/4, HI7750/4)
Trap number	0 to CFG_MAXTRPNO (255 max.)
Attribute supported	TA_HLNG: The task is written in a high-level language TA_ASM: The task is written in assembly language
Restrictions (HI7700/4, HI7750/4)	An exception with an exception code other than a multiple of H'20 is not accepted. Note that such exceptions are not caused.

3.22.1 Define CPU Exception Handler (def_exc, ndef_exc)

C-Language API:

```
ER ercd = def_exc(EXCNO excno, T_DEXC *pk_dexc);  
ER ercd = ndef_exc(EXCNO excno, T_DEXC *pk_dexc);
```

Parameters:

EXCNO	excno	R4	CPU exception handler number
T_DEXC	*pk_dexc	R5	Start address of the definition information of CPU exception handler

Return Parameters:

ER	ercd	R0	Normal end (E_OK) or error code
----	------	----	---------------------------------

Packet Structure:

```
typedef struct t_dexc{  
    ATR    excatr;    0    4    Handler attribute  
    FP    exchdr;    +4   4    Handler address  
    UINT   excsr;    +8   4    SR at initiation (ignored in HI7000/4)  
}T_DEXC;
```

Error Codes:

E_RSATR	[p]	Invalid attribute (excatr is invalid)
E_PAR	[p]	Parameter error (pk_dexc is other than a multiple of four or exchdr is an odd value)

HI7000/4:
Invalid number specification
(excno = 25 or 26, or excno > CFG_MAXVCTNO)

HI7700/4, HI7750/4:
Invalid number specification (excno is other than a multiple of H'20, excno = H'160, or excno > CFG_MAXVCTNO)

Function:

The handler for the CPU exception handler number specified by excno is defined as the content specified by pk_dexc.

The CPU exception handler number is, for the HI7000/4, the CPU vector number, and for the HI7700/4 and HI7750/4, the CPU exception code (EXPEVT code).

For the HI7700/4 and HI7750/4, CPU exception handlers cannot be defined for exception codes for which the EXPEVT code is other than a multiple of H'20. Operation is not guaranteed for exceptions which occur with codes other than multiples of H'20, such as TLB exceptions due to SH3-DSP repeat loops (exception codes H'070 and H'0D0).

The parameter excatr is specified in the following format. See table 3.69 for details.

```
excatr := (TA_HLNG || TA_ASM)
```

Table 3.69 CPU Exception Handler Attributes (excatr)

excatr	Code	Description
TA_HLNG	H'00000000	The handler is written in a high-level language
TA_ASM	H'00000001	The handler is written in assembly language

On the HI7700/4 and HI7750/4, excsr sets the value of the status register (SR) when initiating the interrupt handler. excsr is specified using the same bit position as the SR configuration. For information of SR register, see section 4.2.1, SR Register and section 4.2.2, Cache Lock Function (SH-3, SH3-DSP).

On actual interrupt handler initiation, SR is as follows.

- Interrupt mask bit
Same as before the exception occurred.
- Bits other than the CPU exception mask bit
As specified by excsr

In the HI7000/4, the setting of excsr has no meaning, and is simply ignored. The actual value of SR on startup is determined by the CPU interrupt processing.

When pk_dexc = NULL (0) is specified, the definition of excno is cancelled.

Service calls which can be called from a CPU exception handler are limited to the following service calls. If calls other than the following are called, operation is not guaranteed.

- sns_tex
- sns_ctx
- sns_loc
- sns_dsp
- sns_dpn
- get_tid, iget_tid
- ras_tex, iras_tex
- vsta_knl, ivsta_knl
- vsys_dwn, ivsys_dwn

CPU exception handlers can also be defined statically by the configurator.

In order to define a CPU exception handler for a TRAPA instruction, the service call vdef_trp or ivdef_trp should be used instead of the service calls def_exc and idef_exc.

excsr is a member not defined in the μ ITRON4.0 specification.

3.22.2 Define CPU Exception (TRAPA Instruction Exception) Handler (vdef_trp, ivdef_trp)

C-Language API:

```
ER ercd = vdef_trp(UINT dtrpno, T_DTRP *pk_dtrp);
ER ercd = ivdef_trp(UINT dtrpno, T_DTRP *pk_dtrp);
```

Parameters:

UINT	dtrpno	R4	Trap number
T_DTRP	*pk_dtrp	R5	Pointer to the packet where the CPU exception (TRAPA instruction exception) handler definition information is stored

Return Parameters:

ER	ercd	R0	Normal end (E_OK) or error code
----	------	----	---------------------------------

Packet Structure:

```
typedef struct t_dtrp{
    ATR    trpatr;  0   4   CPU exception (TRAPA instruction
                    exception) handler attribute
    FP    trphdr;  +4  4   CPU exception (TRAPA instruction
                    exception) handler address
    UINT  trpsr;   +8  4   SR at CPU exception (TRAPA
                    instruction exception) handler
                    initiation
}T_DTRP;
```

Error Codes:

E_RSATR	[p]	Invalid attribute (trpatr is invalid)
E_PAR	[p]	Parameter error (pk_dtrp is other than a multiple of four or trphdr is an odd address)
		HI7000/4:
		Invalid number specification (trpno = 25 or 26, or trpno > CFG_MAXVCTNO)
		HI7700/4, HI7750/4:
		Invalid number specification (trpno > CFG_MAXTRPNO)

Function:

Each service call defines a CPU exception (TRAPA instruction exception) handler for the trap number indicated by dtrpno, with the contents specified by pk_dtrp.

The parameter trpatr is specified in the following format. See table 3.70 for details.

```
trpatr:= (TA_HLNG || TA_ASM)
```

Table 3.70 CPU Exception (TRAPA Instruction Exception) Handler Attributes (trpatr)

trpatr	Code	Description
TA_HLNG	H'00000000	The trap routine is written in a high-level language
TA_ASM	H'00000001	The trap routine is written in assembly language

The start address of the CPU exception (TRAPA instruction exception) handler is specified by trphdr. For the HI7700/4 and HI7750/4, the value of the status register (SR) when initiating the CPU exception handler must be specified in trpsr. trpsr is specified using the same bit position as the SR configuration. For information of SR register, see section 4.2.1, SR Register and section 4.2.2, Cache Lock Function (SH-3, SH3-DSP).

On actual CPU exception handler initiation, SR is as follows.

- Interrupt mask bit
Same as before the exception occurred.
- Bits other than the CPU exception mask bit
As specified by trpsr

In the HI7000/4, the setting of trpsr has no meaning, and is simply ignored. The actual value of SR on startup is determined by the CPU exception processing.

When pk_dtrp = NULL (0) is specified, the definition of dtrpno is cancelled.

Service calls which can be called from a CPU exception (TRAPA instruction exception) handler are limited to the following service calls. If calls other than the following are called, normal system operation is not guaranteed.

- sns_tex
- sns_ctx
- sns_loc
- sns_dsp
- sns_dpn
- get_tid, iget_tid
- ras_tex, iras_tex
- vsta_knl, ivsta_knl
- vsys_dwn, ivsys_dwn

CPU exception (TRAPA instruction exception) handlers can also be defined statically by the configurator.

The service calls vdef_trp and ivdef_trp are functions original to the HI7000/4 series.

3.22.3 Refer to Configuration Information (ref_cfg, iref_cfg)

C-Language API:

```
ER ercd = ref_cfg(T_RCFG *pk_rcfg);
```

Parameters:

T_RCFG	*pk_rcfg	R4	Pointer to the packet where the configuration information is to be returned
--------	----------	----	-----------------------------------------------------------------------------

Return Parameters:

ER	ercd	R0	Normal end (E_OK) or error code
T_RCFG	*pk_rcfg	R4	Pointer to the packet where the configuration information is stored

Packet Structure:

```
typedef struct t_rcfg{
    ID maxtskid; 0 2 Maximum task ID
    ID ststkid; +2 2 Maximum ID of task using static
                    stack
    ID maxsemid; +4 2 Maximum semaphore ID
    ID maxflgid; +6 2 Maximum event flag ID
    ID maxdtqid; +8 2 Maximum data queue ID
    ID maxmbxid; +10 2 Maximum mailbox ID
    ID maxmtxid; +12 2 Maximum mutex ID
    ID maxmbfid; +14 2 Maximum message buffer ID
    ID maxmplid; +16 2 Maximum variable-size memory pool ID
    ID maxmpfid; +18 2 Maximum fixed-size memory pool ID
    ID maxcycid; +20 2 Maximum cyclic handler ID
    ID maxalmid; +22 2 Maximum alarm handler ID
    ID maxs_fncd; +24 4 Maximum function code of extended
                    service call
}T_RCFG;
```

Error Codes:

E_PAR	[p]	Parameter error (pk_rcfg is other than a multiple of four)
-------	-----	------------------------------------------------------------

Function:

Each service call returns the system configuration information to the area indicated by pk_rcfg.

The following parameters are returned to the packet specified by pk_rcfg (table 3.71). The name enclosed in parentheses is the corresponding items to be set in the configurator.

Table 3.71 Parameter to Return to Packet Specified by pk_rcfg

Parameter	Description
maxtskid	Returns the maximum task ID (CFG_MAXTSKID)
ststskid	Returns the maximum task ID (CFG_STSTKID) using static stack
maxsemid	Returns the maximum semaphore ID (CFG_MAXSEMID)
maxflgid	Returns the maximum event flag ID (CFG_MAXFLGID)
maxdtqid	Returns the maximum data queue ID (CFG_MAXDTQID)
maxmbxid	Returns the maximum mailbox ID (CFG_MAXMBXID)
maxmtxid	Returns the maximum mutex ID (CFG_MAXMTXID)
maxmbfid	Returns the maximum message buffer ID (CFG_MAXMBFID)
maxmplid	Returns the maximum variable-size memory pool ID (CFG_MAXMPLID)
maxmpfid	Returns the maximum fixed-size memory pool ID (CFG_MAXMPFID)
maxcycid	Returns the maximum cyclic handler ID (CFG_MAXCYCID)
maxalmid	Returns the maximum alarm handler ID (CFG_MAXALMID)
maxs_fncd	Returns the maximum extended SVC function code (CFG_MAXSVCCD)

Note that the value of CFG_MAXCYCID + 1 is returned to the maxcycid when CFG_ACTION is checked.

All members of the T_RCFG structure are not defined in the μ ITRON4.0 specification.

3.22.4 Refer to Version Information (ref_ver, iref_ver)

C-Language API:

```
ER ercd = ref_ver (T_RVER *pk_rver);  
ER ercd = iref_ver (T_RVER *pk_rver);
```

Parameters:

T_RVER	*pk_rver	R4	Pointer to the packet where version information is to be returned
--------	----------	----	-------------------------------------------------------------------

Return Parameters:

ER	ercd	R0	Normal end (E_OK) or error code
T_RVER	*pk_rver	R4	Pointer to the packet where version information is stored

Packet Structure:

```
typedef struct t_rver {  
    UH maker;      0  2  Manufacturer  
    UH prid;      +2  2  Identification number  
    UH spver;     +4  2  Specification version  
    UH prver;     +6  2  Product version  
    UH prno [4]; +8  8  Product management information  
} T_RVER;
```

Error Codes:

E_PAR	[p]	Parameter error (pk_rver is an odd value)
-------	-----	-------------------------------------------

Function:

Each service call reads information on the version of the kernel currently in use and returns it to the area indicated by pk_rver.

The following information is returned to the packet indicated by pk_rver.

- maker
— Indicates the manufacturer of this kernel. The value is H'0115, which means Renesas.
- prid
Indicates the number to identify the OS or VLSI type as follows.
 - HI7000/4: H'0010
 - HI7700/4: H'000F
 - HI7750/4: H'000E

- **spver**
Indicates the specifications to which the kernel conforms, as follows.
 - Bits 15 to 12: MAGIC (Number to identify the TRON specification series)
H'5 (μITRON specifications) for this kernel
 - Bits 11 to 0: SpecVer (Version number of the TRON specification on which the product is based)
H'400 (μITRON version 4.00.00) for this kernel
- **prver**
Indicates the version number of the kernel. Refer to the release note of product appending for the value of prver. The prver of each product at this manual creation time is as follows.
 - HI7000/4 V.2.02.00: H'0220
 - HI7700/4 V.2.02.00: H'0220
 - HI7750/4 V.2.02.00: H'0220
- **prno**
Indicates the product management information and the product number.
The prno[0] to prno[3] values of this kernel are all H'0000.

3.23 Cache Support Function (HI7700/4: for SH-3 and SH3-DSP)

This function is supported only for the HI7700/4 and HI7750/4. As for a cache support function, libraries differ for every microcomputer (table 3.72). And a part of functions and API differ for every library.

Table 3.72 Library of Cache Support Functions

Kernel	CPU	Target Cache	Library
HI7700/4	SH-3, SH3-DSP	Mixed instruction/data	7708_cache_???.lib
	SH4AL-DSP (without extended function)	Instruction cache and operand cache	sh4al_cache_???.lib
	SH4AL-DSP (with extended function)	Instruction cache and operand cache	shx2_cache_???.lib
HI7750/4	SH-4	Operand cache	7750_cache_???.lib
	SH-4A (without extended function)	Instruction cache and operand cache	sh4a_cache_???.lib
	SH-4A (with extended function)	Instruction cache and operand cache	shx2_cache_???.lib

This section explains for SH-3 and SH3-DSP (7708_cache_???.lib).

Cache Support Service Calls: The cache is controlled by the service calls listed in table 3.73.

Table 3.73 Service Calls for Cache Support (for SH-3 and SH3-DSP)

Service Call ¹	Description	System State ²
		T/N/E/D/U/L/C
vini_cac	Initializes cache	T/N/E/D/U
ivini_cac		T/N/E/D/U
vclr_cac	Clears cache	T/N/E/D/U
ivclr_cac		T/N/E/D/U
vfls_cac	Flushes cache	T/N/E/D/U
ivfls_cac		T/N/E/D/U
vinv_cac	Invalidates cache	T/N/E/D/U
ivinv_cac		T/N/E/D/U

- Notes: 1. [S]: Standard profile service calls
 [s]: Service calls that are not standard profile service calls but are needed in order to use the standard profile function
2. T: Can be called from task context
 N: Can be called from non-task context
 E: Can be called from dispatch-enabled state
 D: Can be called from dispatch-disabled state
 U: Can be called from CPU-unlocked state
 L: Can be called from CPU-locked state
 C: Can be called from CPU exception handler

3.23.1 Initialize Cache (vini_cac, ivini_cac)

C-Language API:

```
void vini_cac(UW ccr_data, UW entnum, UW waynum);  
void ivini_cac(UW ccr_data, UW entnum, UW waynum);
```

Parameters:

UW	ccr_data	R4	Value to be set to the cache control register of the CPU
UW	entnum	R5	Number of cache entries
UW	waynum	R6	Number of cache ways

Return Parameters:

None

Error Codes:

None

Function:

This service call initializes the cache. Before using the cache function, call this service call.

The data specified by ccr_data is set to the CCR register.

The number of entries for each cache way is specified by entnum.

The number of ways is specified by waynum.

The parameters entnum and waynum must be set according to CPU specifications and the RAM mode. Otherwise, normal system operation cannot be guaranteed.

The following shows supported cache type and required parameters setting in the vini_cac and ivini_cac in the HI7700/4.

Cache Size	Typical Microcomputers	Condition	Parameters		
			ccr_data	entnum	waynum
8 kbytes	SH7708 series, SH7709	Internal RAM mode not used	Specify a value according to the MCU's specification	128	2
		Internal RAM mode used		128	4
16 kbytes	SH7706, SH7709S, SH7727, SH7641, SH7660	---		256	4
32 kbytes	SH7290, SH7294, SH7300, SH7705, SH7710	32 kbytes mode		512	4
		16 kbytes mode		256	4

If the usage of these service calls is mistaken, coherence between the cache and the memory might not be maintained. When the contents of the cache may not have been written back to the memory and you need to be sure that they have been written back, make the `vfls_cac` or `ivfls_cac` service call to flush the cache before issuing this service call. Specify a value for `ccr_data` such that the CCR.CF bit becomes 1.

When the CCR3 (in the SH7290, etc.) register is to be set, the CCR3 register must be set in the application before this service call is made. Do not access the cache during the period between setting of the CCR3 register and return of program flow from `vini_cac` or `ivini_cac`. For example, have the cache disabled while setting the CCR3 register and issuing `vini_cac` or `ivini_cac`.

In the same way, when the CCR2 (in the SH7709S, SH7290, etc.) register is to be set, the CCR2 register must be set in the application before this service call is made. Do not access the cache between setting of the CCR2 register and the return from `vini_cac` or `ivini_cac`. For example, have the cache disabled while setting the CCR2 register and issuing `vini_cac` or `ivini_cac`.

This service call can be called before the kernel is initiated.

This service call can be called even in the exception block state (BL = 1 in SR).

3.23.2 Clear Cache (vclr_cac, ivclr_cac)

C-Language API:

```
ER ercd = vclr_cac (VP clradr1, VP clradr2);
```

```
ER ercd = ivclr_cac (VP clradr1, VP clradr2);
```

Parameters:

VP	clradr1	R4	Start address
VP	clradr2	R5	End address

Return Parameters:

ER	ercd	R0	Normal end (E_OK) or error code
----	------	----	---------------------------------

Error Codes:

E_PAR	[p]	Parameter error (clradr1 > clradr2)
-------	-----	-------------------------------------

Function:

This service call clears the cache.

If the addresses from clradr1 to clradr2 are cached, the cache contents are invalidated. The contents that have not yet been written to memory are written to memory.

clradr1 and clradr2 must be within physical addresses H'0 to H'1bfffff. If an address outside the range from H'0 to H'1bfffff is specified for clradr1 or clradr2, normal system operation cannot be guaranteed.

To specify all cache contents, specify clradr1 = 0 and clradr2 = H'1bfffff.

In the SH-3 and SH3-DSP, the cache line size is 16 bytes; four least significant bits of clradr1 are corrected to 0s and four least significant bits of clradr2 are corrected to 1s.

If this service call is called before calling the service call vini_cac or ivini_cac, normal system operation cannot be guaranteed.

This service call can be called even in the exception block state (BL = 1 in SR). Therefore, the cache can be cleared irrespective of interrupts or exceptions. When this service call has been called when BL = 1 in SR, clear BL to 0 after returning from the service call processing.

3.23.3 Flush Cache (vfls_cac, ivfls_cac)

C-Language API:

```
ER ercd = vfls_cac (VP flsadr1, VP flsadr2);
ER ercd = ivfls_cac (VP flsadr1, VP flsadr2);
```

Parameters:

VP	flsadr1	R4	Flush start address
VP	flsadr2	R5	Flush end address

Return Parameters:

ER	ercd	R0	Normal end (E_OK) or error code
----	------	----	---------------------------------

Error Codes:

E_PAR	[p]	Parameter error (flsadr1 > flsadr2)
-------	-----	-------------------------------------

Function:

This service call flushes the cache.

If the addresses from flsadr1 to flsadr2 are cached, the contents that have not yet been written to memory are written to memory.

flsadr1 and flsadr2 must be within physical addresses H'0 to H'1bfffff. If an address outside the range from H'0 to H'1bfffff is specified for flsadr1 or flsadr2, normal system operation cannot be guaranteed.

To specify all cache contents, specify flsadr1 = 0 and flsadr2 = H'1bfffff.

In the SH-3 and SH3-DSP, the cache line size is 16 bytes; four least significant bits of flsadr1 are corrected to 0s and four least significant bits of flsadr2 are corrected to 1s.

If this service call is called before calling the service call vini_cac or ivini_cac, the normal system operation cannot be guaranteed.

This service call can be called even in the exception block state (BL = 1 in SR). Therefore, the cache can be flushed irrespective of interrupts or exceptions. When this service call has been called when BL = 1 in SR, clear BL to 0 after returning from the service call processing.

3.23.4 Invalidate Cache (vinv_cac, ivinv_cac)

C-Language API:

```
ER ercd = vinv_cac (void);  
ER ercd = ivinv_cac (void);
```

Parameters:

None

Return Parameters:

ER ercd R0 Normal end (E_OK) or error code

Error Codes:

None

Function:

This service call invalidates the cache.

Keep in mind that the contents are canceled even if there is data which is not written back to the memory yet in the cache.

This service call sets the cache flush bit (CF) in the cache control register (CCR) to 1 to invalidate all cached contents.

If this service call is called before calling the service call vini_cac or ivini_cac, the normal system operation cannot be guaranteed.

This service call can be called even in the exception block state (BL = 1 in SR). Therefore, the cache can be invalidated irrespective of interrupts or exceptions. When this service call has been called when BL = 1 in SR, clear BL to 0 after returning from the service call processing.

3.24 Cache Support Function (HI7750/4: for SH-4)

This function is supported only for the HI7700/4 and HI7750/4. As for a cache support function, libraries differ for every microcomputer (table 3.74). And a part of functions and API differ for every library.

Table 3.74 Library of Cache Support Functions

Kernel	CPU	Target Cache	Library
HI7700/4	SH-3, SH3-DSP	Mixed instruction/data	7708_cache_???.lib
	SH4AL-DSP (without extended function)	Instruction cache and operand cache	sh4al_cache_???.lib
	SH4AL-DSP (with extended function)	Instruction cache and operand cache	shx2_cache_???.lib
HI7750/4	SH-4	Operand cache	7750_cache_???.lib
	SH-4A (without extended function)	Instruction cache and operand cache	sh4a_cache_???.lib
	SH-4A (with extended function)	Instruction cache and operand cache	shx2_cache_???.lib

This section explains for SH-4 (7750_cache_???.lib).

Cache Support Service Calls: The cache is controlled by the service calls listed in table 3.75.

Table 3.75 Service Calls for Cache Support (for SH-4)

Service Call ¹	Description	System State ²
		T/N/E/D/U/L/C
vini_cac	Initializes cache	T/N/E/D/U
ivini_cac		T/N/E/D/U
vclr_cac	Clears operand cache	T/N/E/D/U
ivclr_cac		T/N/E/D/U
vfls_cac	Flushes operand cache	T/N/E/D/U
ivfls_cac		T/N/E/D/U
vinv_cac	Invalidates operand cache	T/N/E/D/U
ivinv_cac		T/N/E/D/U

Notes: 1. [S]: Standard profile service calls

[s]: Service calls that are not standard profile service calls but are needed in order to use the standard profile function

2. T: Can be called from task context

N: Can be called from non-task context

E: Can be called from dispatch-enabled state

D: Can be called from dispatch-disabled state

U: Can be called from CPU-unlocked state

L: Can be called from CPU-locked state

C: Can be called from CPU exception handler

3.24.1 Initialize Cache (vini_cac, ivini_cac)

C-Language API:

```
void vini_cac(UW ccr_data);  
void ivini_cac(UW ccr_data);
```

Parameters:

UW ccr_data R4 Value to be set to the cache control register of the CPU

Return Parameters:

None

Error Codes:

None

Function:

This service call initializes the cache. Before using the cache function, call this service call.

The data specified by ccr_data is set to the CCR register.

If the usage of these service calls is mistaken, coherence between the cache and the memory might not be maintained. When the contents of the cache may not have been written back to the memory and you need to be sure that they have been written back, make the vfls_cac or ivfls_cac service call to flush the cache before issuing this service call. Specify a value for ccr_data such that the CCR.CF bit becomes 1.

This service call can be called before the kernel is initiated.

This service call can be called even in the exception block state (BL = 1 in SR).

3.24.2 Clear Operand Cache (vclr_cac, ivclr_cac)

C-Language API:

```
ER ercd = vclr_cac (VP clradr1, VP clradr2);
```

```
ER ercd = ivclr_cac (VP clradr1, VP clradr2);
```

Parameters:

VP	clradr1	R4	Start address
VP	clradr2	R5	End address

Return Parameters:

ER	ercd	R0	Normal end (E_OK) or error code
----	------	----	---------------------------------

Error Codes:

E_PAR	[p]	Parameter error (clradr1 > clradr2)
-------	-----	-------------------------------------

Function:

This service call clears the operand cache.

If the addresses from clradr1 to clradr2 are cached in the operand cache, the cache contents are invalidated. The contents that have not yet been written to memory are written to memory.

clradr1 and clradr2 must be logical addresses.

If the address range from clradr1 to clradr2 includes one of the following, normal system operation cannot be guaranteed.

- Address corresponding to an physical address in area 7
- Address in P2 or P4 area

To specify all cache contents, specify clradr1 = H'80000000 and clradr2 = H'9bffff.

In the SH-4, the cache line size is 32 bytes; five least significant bits of clradr1 are corrected to 0s and five least significant bits of clradr2 are corrected to 1s.

This service call can be called before the kernel is initiated.

This service call can be called even in the exception block state (BL = 1 in SR). Therefore, the cache can be cleared irrespective of interrupts or exceptions. When this service call has been called when BL = 1 in SR, clear BL to 0 after returning from the service call processing.

3.24.3 Flush Operand Cache (vfls_cac, ivfls_cac)

C-Language API:

```
ER ercd = vfls_cac (VP flsadr1, VP flsadr2);
```

```
ER ercd = ivfls_cac (VP flsadr1, VP flsadr2);
```

Parameters:

VP	flsadr1	R4	Flush start address
VP	flsadr2	R5	Flush end address

Return Parameters:

ER	ercd	R0	Normal end (E_OK) or error code
----	------	----	---------------------------------

Error Codes:

E_PAR	[p]	Parameter error (flsadr1 > flsadr2)
-------	-----	-------------------------------------

Function:

This service call flushes the operand cache.

If the addresses from flsadr1 to flsadr2 are cached in the operand cache, the contents that have not yet been written to memory are written to memory.

flsadr1 and flsadr2 must be logical addresses.

If the address range from flsadr1 to flsadr2 includes one of the following addresses, normal system operation cannot be guaranteed.

- Address corresponding to an physical address in area 7
- Address in P2 or P4 area

To specify all cache contents, specify flsadr1 = H'80000000 and flsadr2 = H'9bffff.

In the SH-4, the cache line size is 32 bytes; five least significant bits of flsadr1 are corrected to 0s and five least significant bits of flsadr2 are corrected to 1s.

This service call can be called before the kernel is initiated.

This service call can be called even in the exception block state (BL = 1 in SR). Therefore, the cache can be flushed irrespective of interrupts or exceptions. When this service call has been called when BL = 1 in SR, clear BL to 0 after returning from the service call processing.

3.24.4 Invalidate Operand Cache (vinv_cac, ivinv_cac)

C-Language API:

```
ER ercd = vinv_cac (VP invadr1, VP invadr2);  
ER ercd = ivinv_cac (VP invadr1, VP invadr2);
```

Parameters:

VP	invadr1	R4	Start address of invalidation
VP	invadr2	R5	End address of invalidation

Return Parameters:

ER	ercd	R0	Normal end (E_OK) or error code
----	------	----	---------------------------------

Error Codes:

E_PAR	[p]	Parameter error (invadr1 > invadr2)
-------	-----	-------------------------------------

Function:

This service call invalidates the operand cache.

Keep in mind that the contents are canceled even if there is data which is not written back to the memory yet in the cache.

If the addresses from invadr1 to invadr2 are cached in the operand cache, the contents are invalidated even if the contents have not yet been written to memory.

invadr1 and invadr2 must be logical addresses.

If the address range from invadr1 to invadr2 includes one of the following addresses, normal system operation cannot be guaranteed.

- Address corresponding to an physical address in area 7
- Address in P2 or P4 area

To specify all cache contents, specify invadr1 = H'80000000 and invadr2 = H'9bffffff.

In the SH-4, the cache line size is 32 bytes; five least significant bits of invadr1 are corrected to 0s and five least significant bits of invadr2 are corrected to 1s.

This service call can be called before the kernel is initiated.

This service call can be called even in the exception block state (BL = 1 in SR). Therefore, the cache can be invalidated irrespective of interrupts or exceptions. When this service call has been called when BL = 1 in SR, clear BL to 0 after returning from the service call processing.

3.25 Cache Support Function (HI7700/4: for SH4AL-DSP without Extended Function, HI7750/4: for SH-4A without Extended Function)

This function is supported only for the HI7700/4 and HI7750/4. As for a cache support function, libraries differ for every microcomputer (table 3.76). And a part of functions and API differ for every library.

Table 3.76 Library of Cache Support Functions

Kernel	CPU	Target Cache	Library
HI7700/4	SH-3, SH3-DSP	Mixed instruction/data	7708_cache_???.lib
	SH4AL-DSP (without extended function)	Instruction cache and operand cache	sh4al_cache_???.lib
	SH4AL-DSP (with extended function)	Instruction cache and operand cache	shx2_cache_???.lib
HI7750/4	SH-4	Operand cache	7750_cache_???.lib
	SH-4A (without extended function)	Instruction cache and operand cache	sh4a_cache_???.lib
	SH-4A (with extended function)	Instruction cache and operand cache	shx2_cache_???.lib

The specifications of the library for SH4AL-DSP without extended function (sh4al_cache_???.lib) and the library for SH-4A without extended function (sh4a_cache_???.lib) are the same, and this section explains the specification of them.

In addition, be sure to refer to following sections.

- 5.7, When Cache Support Function is Used on SH4AL-DSP (HI7700/4) or SH-4A (HI7750/4).
- 5.11.1, CPU Options for the Compiler and Assembler.

Cache Support Service Calls: The cache is controlled by the service calls listed in table 3.77.

Table 3.77 Service Calls for Cache Support (for SH4AL-DSP without Extended Function and SH-4A without Extended Function)

Service Call ¹	Description	System State ²
		T/N/E/D/U/L/C
vini_cac	Initializes cache	T/N/E/D/U
ivini_cac		T/N/E/D/U
vclr_cac	Clears instruction/operand cache	T/N/E/D/U
ivclr_cac		T/N/E/D/U
vfls_cac	Flushes operand cache	T/N/E/D/U
ivfls_cac		T/N/E/D/U
vinv_cac	Invalidates instruction/operand cache	T/N/E/D/U
ivinv_cac		T/N/E/D/U

- Notes: 1. [S]: Standard profile service calls
[s]: Service calls that are not standard profile service calls but are needed in order to use the standard profile function
2. T: Can be called from task context
N: Can be called from non-task context
E: Can be called from dispatch-enabled state
D: Can be called from dispatch-disabled state
U: Can be called from CPU-unlocked state
L: Can be called from CPU-locked state
C: Can be called from CPU exception handler

3.25.1 Initialize Cache (vini_cac, ivini_cac)

C-Language API:

```
void vini_cac(ATR cacatr);  
void ivini_cac(ATR cacatr);
```

Parameters:

ATR ccratr R4 Cache attribute

Return Parameters:

ER ercd R0 Normal end (E_OK)

Error Codes:

None

Function:

This service call initializes the cache. Before using the cache function, call this service call.

Specifically, based on specified cacatr, as shown in table 3.78, the CCR register and RAMCR register of a processor are set up.

Although the logical sum of each item of table 3.78 can be specified to be cacatr, no error check of the value specified to be cacatr is performed.

Moreover, this service call is not concerned with the contents of specification of cacatr, but writes 1 in the CCR.ICI and CCR.OCI bit. That is, all the contents of the cache before this service call are canceled.

In addition, in this service call, no registers other than CCR and RAMCR are changed.

This service call can be called before the kernel is initiated.

This service call can be called even in the exception block state (BL = 1 in SR).

Table 3.78 Cache Attribute

Attribute	Value	Description	CCR and RAMCR Setting
TCAC_IC_ENABLE	H'00000100	When specify	Enable instruction cache CCR.ICE = 1
		When not specify	Disable instruction cache CCR.ICE = 0
TCAC_OC_ENABLE	H'00000001	When specify	Enable operand cache CCR.OCE = 1
		When not specify	Disable operand cache CCR.OCE = 0
TCAC_IC_2WAY	H'00800000	When specify	2-way instruction cache RAMCR.IC2W = 1
		When not specify	4-way instruction cache RAMCR.IC2W = 0
TCAC_OC_2WAY	H'00400000	When specify	2-way operand cache RAMCR.OC2W = 1
		When not specify	4-way operand cache RAMCR.OC2W = 0
TCAC_P1_CB	H'00000004	When specify	Writing mode for P1 area is write-back mode CCR.CB = 1
		When not specify	Writing mode for P1 area is write-through mode CCR.CB = 0
TCAC_P0_WT	H'00000002	When specify	Writing mode for P0/U0 area is write-through mode CCR.WT = 1
		When not specify	Writing mode for P0/U0 area is write-back mode CCR.WT = 0

3.25.2 Clear Instruction/Operand Cache (vclr_cac, ivclr_cac)

C-Language API:

```
ER ercd = vclr_cac (VP clradr1, VP clradr2, MODE mode);
```

```
ER ercd = ivclr_cac (VP clradr1, VP clradr2, MODE mode);
```

Parameters:

VP	clradr1	R4	Start address
VP	clradr2	R5	End address
MODE	mode	R6	Target cache

Return Parameters:

ER	ercd	R0	Normal end (E_OK) or error code
----	------	----	---------------------------------

Error Codes:

E_PAR	[p]	Parameter error (clradr1 > clradr2 or mode is invalid)
E_OBJ	[k]	Target cache is disabled.

Function:

This service call clears the cache. That is, the cache contents are invalidated. If the operand cache has data which has not been written to memory, the data is written-back to memory.

The target cache are determined by mode. Following either can be specified to be mode.

- TC_FULL(H'00000000): Both instruction cache and operand cache
- TC_EXCLUDE_IC(H'00000001): Exclude instruction cache (only operand cache)
- TC_EXCLUDE_OC(H'00000002): Exclude operand cache (only instruction cache)

clradr1 is omitted to the multiple of 32, and clradr2 is revalued to the multiple -1 of 32.

(1) Clear specified range

This service call clears the cache entry whose logical address is from clradr1 to clradr2. If operand cache are contained in target, before canceling a dirty entry, it is written-back to memory.

This service call repeats and executes the following instructions from clradr1 to clradr2.

- mode = TC_FULL: ICBI and OCBP
- mode = TC_EXCLUDE_IC: OCBI
- mode = TC_EXCLUDE_OC: ICBI

This processing is performed in the state of SR.BL = 0 and SR.I = 15. However, whenever it processes one entry, this service call restores SR at the time of this call. That is, interruption may be accepted by SR at the time of this call.

Section3 Service Calls

In this service call, only the fundamental error check indicated in the error code column is performed about cladr1 and cladr2. For example, the following addresses should not be contained.

- P2 and P4 areas
- Address corresponding to a physical address in the control area
- Address corresponding to a physical address in X/Y memory

The processing time of this service call is proportional to the size of the appointed domain.

(2) Clear all

If 0 is specified to be cladr1 and H'ffffff is specified to be cladr2, all the entries of the target cache determined by mode will be cleared. In this case, this service call is processed as follows.

1. When mode is TC_FULL or TC_EXCLUDE_OC, it is setting 1 as the ICI bit of a CCR register, and all the entries of instruction cache are cleared. This processing is performed in the state of SR.BL = 1.
2. When mode is TC_FULL or TC_EXCLUDE_IC, all entries of operand cache are cleared after writing-back the dirty entry of operand cache to memory. This processing is performed in the state of SR.BL = 1. However, whenever it processes one entry, this service call restores SR at the time of this call. That is, interruption may be accepted by SR at the time of this call.

In the HI7750/4, this service call can be called before the kernel is initiated.

This service call can be called even in the exception block state (BL = 1 in SR). Therefore, the cache can be cleared irrespective of interrupts or exceptions. When this service call has been called when BL = 1 in SR, clear BL to 0 after returning from the service call processing.

3.25.3 Flush Operand Cache (vfls_cac, ivfls_cac)

C-Language API:

```
ER ercd = vfls_cac (VP flsadr1, VP flsadr2);
```

```
ER ercd = ivfls_cac (VP flsadr1, VP flsadr2);
```

Parameters:

VP	flsadr1	R4	Flush start address
VP	flsadr2	R5	Flush end address

Return Parameters:

ER	ercd	R0	Normal end (E_OK) or error code
----	------	----	---------------------------------

Error Codes:

E_PAR	[p]	Parameter error (flsadr1 > flsadr2)
E_OBJ	[k]	Operand cache is disabled.

Function:

This service call flushes the operand cache. That is, If the operand cache has data which has not been written to memory, the data is written-back to memory.

flsadr1 is omitted to the multiple of 32, and flsadr2 is revalued to the multiple -1 of 32.

(1) Flush specified range

This service call flushes the operand cache entry whose logical address is from flsadr1 to flsadr2.

This service call repeats and executes the OCBWB instruction from flsadr1 to flsadr2. This processing is performed in the state of SR.BL = 0 and SR.I = 15. However, whenever it processes one entry, this service call restores SR at the time of this call. That is, interruption may be accepted by SR at the time of this call.

In this service call, only the fundamental error check indicated in the error code column is performed on flsadr1 and flsadr2. For example, the following addresses should not be contained.

- P2 and P4 areas
- Address corresponding to a physical address in the control area
- Address corresponding to a physical address in X/Y memory

The processing time of this service call is proportional to the size of the appointed domain.

(2) Flush all

If 0 is specified to be flsadr1 and H'ffffff is specified to be flsadr2, all the entries of the operand cache will be cleared. In this case, this service call is processed as follows.

- The operand cache entry which is dirty is written-back to memory. This processing is performed in the state of SR.BL = 1. However, whenever it processes one entry, this service call restores SR at the time of this call. That is, interruption may be accepted by SR at the time of this call.

In the HI7750/4, this service call can be called before the kernel is initiated.

This service call can be called even in the exception block state (BL = 1 in SR). Therefore, the cache can be flushed irrespective of interrupts or exceptions. When this service call has been called when BL = 1 in SR, clear BL to 0 after returning from the service call processing.

3.25.4 Invalidate Instruction/Operand Cache (vinv_cac, ivinv_cac)

C-Language API:

```
ER ercd = vinv_cac (VP invadr1, VP invadr2, MODE mode);
ER ercd = ivinv_cac (VP invadr1, VP invadr2, MODE mode);
```

Parameters:

VP	invadr1	R4	Start address of invalidation
VP	invadr2	R5	End address of invalidation
MODE	mode	R6	Target cache

Return Parameters:

ER	ercd	R0	Normal end (E_OK) or error code
----	------	----	---------------------------------

Error Codes:

E_PAR	[p]	Parameter error (invadr1 > invadr2 or mode is invalid)
E_OBJ	[k]	Target cache is disabled.

Function:

The service call vinv_cac invalidates the cache. It is canceled even if the data which has not been written-back to memory is in operand cache.

The target cache are determined by mode. Following either can be specified to be mode.

- TC_FULL(H'00000000): Both instruction cache and operand cache
- TC_EXCLUDE_IC(H'00000001): Exclude instruction cache (only operand cache)
- TC_EXCLUDE_OC(H'00000002): Exclude operand cache (only instruction cache)

invadr1 is omitted to the multiple of 32, and invadr2 is revalued to the multiple -1 of 32.

(1) Invalidate specified range

This service call invalidates the cache entry whose logical address is from invadr1 to invadr2.

This service call repeats and executes the following instructions from cladr1 to cladr2.

- mode = TC_FULL: ICBI and OCBI
- mode = TC_EXCLUDE_IC: OCBI
- mode = TC_EXCLUDE_OC: ICBI

This processing is performed in the state of SR.BL = 0 and SR.I = 15. However, whenever it processes one entry, this service call restores SR at the time of this call. That is, interruption may be accepted by SR at the time of this call.

Section3 Service Calls

In this service call, only the fundamental error check indicated in the error code column is performed on `invadr1` and `invadr2`. For example, the following addresses should not be contained.

- P2 and P4 areas
- Address corresponding to a physical address in the control area
- Address corresponding to a physical address in X/Y memory

The processing time of this service call is proportional to the size of the appointed domain.

(2) Invalidate all

If 0 is specified to be `invadr1` and `H'ffffff` is specified to be `invadr2`, all the entries of the target cache determined by mode will be invalidated. In this case, this service call operates the following bits of the CCR register according to mode. This processing is performed in the state of `SR.BL = 1`.

- mode = `TC_FULL`: Writes 1 to ICI bit and OCI bit
- mode = `TC_EXCLUDE_IC`: Writes 1 to OCI bit
- mode = `TC_EXCLUDE_OC`: Writes 1 to ICI bit

In the HI7750/4, this service call can be called before the kernel is initiated.

This service call can be called even in the exception block state (`BL = 1` in `SR`). Therefore, the cache can be invalidated irrespective of interrupts or exceptions. When this service call has been called when `BL = 1` in `SR`, clear `BL` to 0 after returning from the service call processing.

3.26 Cache Support Function (HI7700/4: for SH4AL-DSP with Extended Function, HI7750/4: for SH-4A with Extended Function)

This function is supported only for the HI7700/4 and HI7750/4. As for a cache support function, libraries differ for every microcomputer (table 3.79). And a part of functions and API differ for every library.

Table 3.79 Library of Cache Support Function

Kernel	CPU	Target Cache	Library
HI7700/4	SH-3, SH3-DSP	Mixed instruction/data	7708_cache_???.lib
	SH4AL-DSP (without extended function)	Instruction cache and operand cache	sh4al_cache_???.lib
	SH4AL-DSP (with extended function)	Instruction cache and operand cache	shx2_cache_???.lib
HI7750/4	SH-4	Operand cache	7750_cache_???.lib
	SH-4A (without extended function)	Instruction cache and operand cache	sh4a_cache_???.lib
	SH-4A (with extended function)	Instruction cache and operand cache	shx2_cache_???.lib

The specifications of the library for SH4AL-DSP with extended function (shx2_cache_???.lib) and the library for SH-4A with extended function (shx2_cache_???.lib) are the same, and this section explains the specification of them.

In addition, be sure to refer to the following sections.

- 5.7, When Cache Support Function is Used on SH4AL-DSP (HI7700/4) or SH-4A (HI7750/4).
- 5.11.1, CPU Options for the Compiler and Assembler.

Cache Support Service Calls: The cache is controlled by the service calls listed in table 3.80.

Table 3.80 Service Calls for Cache Support (for SH4AL-DSP with Extended Function and SH-4A with Extended Function)

Service Call ¹	Description	System State ²
		T/N/E/D/U/L/C
vini_cac	Initializes cache	T/N/E/D/U
ivini_cac		T/N/E/D/U
vclr_cac	Clears instruction/operand cache	T/N/E/D/U
ivclr_cac		T/N/E/D/U
vfls_cac	Flushes operand cache	T/N/E/D/U
ivfls_cac		T/N/E/D/U
vinv_cac	Invalidates instruction/operand cache	T/N/E/D/U
ivinv_cac		T/N/E/D/U

- Notes: 1. [S]: Standard profile service calls
 [s]: Service calls that are not standard profile service calls but are needed in order to use the standard profile function
2. T: Can be called from task context
 N: Can be called from non-task context
 E: Can be called from dispatch-enabled state
 D: Can be called from dispatch-disabled state
 U: Can be called from CPU-unlocked state
 L: Can be called from CPU-locked state
 C: Can be called from CPU exception handler

3.26.1 Initialize Cache (vini_cac, ivini_cac)

C-Language API:

```
void vini_cac(ATR cacatr);  
void ivini_cac(ATR cacatr);
```

Parameters:

ATR ccratr R4 Cache attribute

Return Parameters:

ER ercd R0 Normal end (E_OK)

Error Codes:

None

Function:

This service call initializes the cache. Before using the cache function, call this service call.

Specifically, based on specified cacatr, as shown in table 3.78, the CCR register and RAMCR register of a processor are set up.

Although the logical sum of each item of table 3.81 can be specified to be cacatr, no error check of the value specified to be cacatr is performed.

Moreover, this service call is not concerned with the contents of specification of cacatr, but writes 1 in the CCR.ICI and CCR.OCI bit. That is, all the contents of the cache before this service call are canceled.

When the target microcomputer does not have a secondary cache, do not specify TCAC_L2_ENABLE or TCAC_L2_FC.

In addition, in this service call, no registers other than CCR and RAMCR are changed.

This service call can be called before the kernel is initiated.

This service call can be called even in the exception block state (BL = 1 in SR).

Table 3.81 Cache Attribute

Attribute	Value	Description		CCR and RAMCR Setting
TCAC_IC_ENABLE	H'00000100	When specify	Enable instruction cache	CCR.ICE = 1
		When not specify	Disable instruction cache	CCR.ICE = 0
TCAC_OC_ENABLE	H'00000001	When specify	Enable operand cache	CCR.OCE = 1
		When not specify	Disable operand cache	CCR.OCE = 0
TCAC_IC_2WAY	H'00800000	When specify	2-way instruction cache	RAMCR.IC2W = 1
		When not specify	4-way instruction cache	RAMCR.IC2W = 0
TCAC_OC_2WAY	H'00400000	When specify	2-way operand cache	RAMCR.OC2W = 1
		When not specify	4-way operand cache	RAMCR.OC2W = 0
TCAC_P1_CB	H'00000004	When specify	Writing mode for P1 area is write-back mode	CCR.CB = 1
		When not specify	Writing mode for P1 area is write-through mode	CCR.CB = 0
TCAC_P0_WT	H'00000002	When specify	Writing mode for P0/U0 area is write-through mode	CCR.WT = 1
		When not specify	Writing mode for P0/U0 area is write-back mode	CCR.WT = 0
TCAC_IC_WPD	H'00200000	When specify	Does not predict the instruction cache way	CCR.ICWPD = 1
		When not specify	Predicts the instruction cache way	CCR.ICWPD = 0
TCAC_L2_ENABLE	H'00010000	When specify	Enable secondary cache	RAMCR.L2E = 1
		When not specify	Disable secondary cache	RAMCR.L2E = 0

Table 3.81 Cache Attribute (cont)

Attribute	Value	Description		CCR and RAMCR Setting
TCAC_L2_FC	H'00020000	When specify	Secondary cache operates in forcible coherency mode	RAMCR.L2FC = 1
		When not specify	Secondary cache does not operate in forcible coherency mode	RAMCR.L2FC = 0

3.26.2 Clear Instruction/Operand Cache (vclr_cac, ivclr_cac)

C-Language API:

```
ER ercd = vclr_cac (VP clradr1, VP clradr2, MODE mode);  
ER ercd = ivclr_cac (VP clradr1, VP clradr2, MODE mode);
```

Parameters:

VP	clradr1	R4	Start address
VP	clradr2	R5	End address
MODE	mode	R6	Target cache

Return Parameters:

ER	ercd	R0	Normal end (E_OK) or error code
----	------	----	---------------------------------

Error Codes:

E_PAR	[p]	Parameter error (clradr1 > clradr2 or mode is invalid)
E_OBJ	[k]	Target cache is disabled.

Function:

This service call clears the cache. That is, the cache contents are invalidated. If the operand cache has data which has not been written to memory, the data is written-back to memory.

The target cache is determined by mode. Following either can be specified to be mode.

- TC_FULL(H'00000000): Both instruction cache and operand cache
- TC_EXCLUDE_IC(H'00000001): Exclude instruction cache (only operand cache)
- TC_EXCLUDE_OC(H'00000002): Exclude operand cache (only instruction cache)

clradr1 is omitted to the multiple of 32, and clradr2 is revalued to the multiple -1 of 32.

(1) Clear specified range

This service call clears the cache entry whose logical address is from clradr1 to clradr2. If operand cache is contained in target, before canceling a dirty entry, it is written-back to memory.

This service call repeats and executes the following instructions from clradr1 to clradr2.

- mode = TC_FULL: ICBI and OCBP
- mode = TC_EXCLUDE_IC: OCBI
- mode = TC_EXCLUDE_OC: ICBI

During this processing, the SR value remains the same as when this function is called. When no interrupt should be accepted during this function processing, mask interrupts and then call this function.

In this service call, only the fundamental error check indicated in the error code column is performed on cladr1 and cladr2. For example, the following addresses should not be contained.

- P2 and P4 areas
- Address corresponding to a physical address in the control area
- Address corresponding to a physical address in X/Y memory

The processing time of this service call is proportional to the size of the appointed domain.

(2) Clear all

If 0 is specified to be cladr1 and H'ffffff is specified to be cladr2, all the entries of the target cache determined by mode will be cleared. In this case, this service call is processed as follows.

1. When mode is TC_FULL or TC_EXCLUDE_OC, it is setting 1 as the ICI bit of a CCR register, and all the entries of instruction cache are cleared. This processing is performed in the state of SR.BL = 1.
2. When mode is TC_FULL or TC_EXCLUDE_IC, the OCBP instruction is executed for all entries of the memory-mapped operand cache to write back the dirty (U = 1) entries to memory and invalidates (V = 0) them. During this processing, the SR value remains the same as when this function is called. When no interrupt should be accepted during this function processing, mask interrupts and then call this function.

In the HI7750/4, this service call can be called before the kernel is initiated.

This service call can be called even in the exception block state (BL = 1 in SR). Therefore, the cache can be cleared irrespective of interrupts or exceptions. When this service call has been called when BL = 1 in SR, clear BL to 0 after returning from the service call processing.

3.26.3 Flush Operand Cache (vfls_cac, ivfls_cac)

C-Language API:

```
ER ercd = vfls_cac (VP flsadr1, VP flsadr2);
```

```
ER ercd = ivfls_cac (VP flsadr1, VP flsadr2);
```

Parameters:

VP	flsadr1	R4	Flush start address
VP	flsadr2	R5	Flush end address

Return Parameters:

ER	ercd	R0	Normal end (E_OK) or error code
----	------	----	---------------------------------

Error Codes:

E_PAR	[p]	Parameter error (flsadr1 > flsadr2)
E_OBJ	[k]	Operand cache is disabled.

Function:

This service call flushes the operand cache. That is, if the operand cache has data which has not been written to memory, the data is written-back to memory.

flsadr1 is omitted to the multiple of 32, and flsadr2 is revalued to the multiple -1 of 32.

(1) Flush specified range

This service call flushes the entries corresponding to the logical address range from flsadr1 to flsadr2 in the operand cache, that is, when the specified entries have not been written to memory, the entries are copied back to memory.

This service call repeats execution of the OCBWB instruction for the range from flsadr1 to flsadr2. During this processing, the SR value remains the same as when this function is called. When no interrupt should be accepted during this function processing, mask interrupts and then call this function.

In this service call, only the fundamental error check indicated in the error code column is performed on flsadr1 and flsadr2. For example, the following addresses should not be contained.

- P2 and P4 areas
- Address corresponding to a physical address in the control area
- Address corresponding to a physical address in X/Y memory

The processing time of this service call is proportional to the size of the appointed domain.

(2) Flush all

If 0 is specified to be flsadr1 and H'ffffff is specified to be flsadr2, all the entries of the operand cache will be cleared. In this case, this service call is processed as follows.

- The OCBP instruction is executed for all entries of the memory-mapped operand cache to write back the dirty ($U = 1$) entries to memory and invalidates ($V = 0$) them. During this processing, the SR value remains the same as when this function is called. When no interrupt should be accepted during this function processing, mask interrupts and then call this function.

In the HI7750/4, this service call can be called before the kernel is initiated.

This service call can be called even in the exception block state ($BL = 1$ in SR). Therefore, the cache can be flushed irrespective of interrupts or exceptions. When this service call has been called when $BL = 1$ in SR, clear BL to 0 after returning from the service call processing.

3.26.4 Invalidate Instruction/Operand Cache (vinv_cac, ivinv_cac)

C-Language API:

```
ER ercd = vinv_cac (VP invadr1, VP invadr2, MODE mode);  
ER ercd = ivinv_cac (VP invadr1, VP invadr2, MODE mode);
```

Parameters:

VP	invadr1	R4	Start address of invalidation
VP	invadr2	R5	End address of invalidation
MODE	mode	R6	Target cache

Return Parameters:

ER	ercd	R0	Normal end (E_OK) or error code
----	------	----	---------------------------------

Error Codes:

E_PAR	[p]	Parameter error (invadr1 > invadr2 or mode is invalid)
E_OBJ	[k]	Target cache is disabled.

Function:

The service call vinv_cac invalidates the cache. It is canceled even if the data which has not been written-back to memory is in operand cache.

The target cache are determined by mode. Following either can be specified to be mode.

- TC_FULL(H'00000000): Both instruction cache and operand cache
- TC_EXCLUDE_IC(H'00000001): Exclude instruction cache (only operand cache)
- TC_EXCLUDE_OC(H'00000002): Exclude operand cache (only instruction cache)

invadr1 is omitted to the multiple of 32, and invadr2 is revalued to the multiple -1 of 32.

(1) Invalidate specified range

This service call invalidates the cache entry whose logical address is from invadr1 to invadr2.

This service call repeats and executes the following instructions from cladr1 to cladr2.

- mode = TC_FULL: ICBI and OCBI
- mode = TC_EXCLUDE_IC: OCBI
- mode = TC_EXCLUDE_OC: ICBI

During this processing, the SR value remains the same as when this function is called. When no interrupt should be accepted during this function processing, mask interrupts and then call this function.

In this service call, only the fundamental error check indicated in the error code column is performed on `invadr1` and `invadr2`. For example, the following addresses should not be contained.

- P2 and P4 areas
- Address corresponding to a physical address in the control area
- Address corresponding to a physical address in X/Y memory

The processing time of this service call is proportional to the size of the appointed domain.

(2) Invalidate all

If 0 is specified to be `invadr1` and `H'ffffff` is specified to be `invadr2`, all the entries of the target cache determined by mode will be invalidated. In this case, this service call operates the following bits of the CCR register according to mode. This processing is performed in the state of `SR.BL = 1`.

- mode = `TC_FULL`: Writes 1 to ICI bit and OCI bit
- mode = `TC_EXCLUDE_IC`: Writes 1 to OCI bit
- mode = `TC_EXCLUDE_OC`: Writes 1 to ICI bit

In the HI7750/4, this service call can be called before the kernel is initiated.

This service call can be called even in the exception block state (`BL = 1` in `SR`). Therefore, the cache can be invalidated irrespective of interrupts or exceptions. When this service call has been called when `BL = 1` in `SR`, clear `BL` to 0 after returning from the service call processing.

Section 4 Application Program Creation

4.1 Header Files

4.1.1 Header Files for C/C++ Language

(1) `itron.h`

`itron.h` is a header file where the common ITRON specification definitions are described for C/C++ language. This file can be found in the `hihead` folder.

(2) `kernel.h` and `kernel_macro.h`

`kernel.h` is a header file where the μ ITRON4.0 kernel specification definitions are described for C/C++ language. `kernel.h` includes `itron.h` and `kernel_macro.h` that is output from the configurator. `kernel.h` can be found in the `hihead` folder.

Section 3, Service Calls, describes the service calls by using the data types, constants, and macros defined in the above header files. Note, however, that the above header files include some constants and macros that are not described in section 3. These are listed in table 4.1. For details, refer to the description on header files.

Table 4.1 Constants and Macros

File Name	Macro and Constants	Description
kernel.h	TMIN_TPRI	Minimum task priority value (always 1)
	TMIN_MPRI	Minimum message priority value (always 1)
	TKERNEL_MAKER	Kernel manufacturer code This value is the same as maker which is returned by ref_ver service call.
	TKERNEL_PRID	Kernel ID This value is the same as prid which is returned by ref_ver service call.
	TKERNEL_SPVER	ITRON specification version number This value is the same as spver which is returned by ref_ver service call.
	TKERNEL_PRVER	Kernel version number This value is the same as prver which is returned by ref_ver service call.
	TMAX_ACTCNT	Maximum number of task initiation request queues (always 15)
	TMAX_WUPCNT	Maximum number of task wake-up request queues (always 15)
	TMAX_SUSCNT	Maximum number of nestings for task forced wait request (always 15)
	TBIT_TEXPTN	Number of task exception factor bits (always 32)
	TBIT_FLGPTN	Number of event flag bits (always 32)
	SIZE mpfsz = TSZ_MPF(UNIT blkcnt, UNIT blkksz);	The size of fixed-size memory pool area required to store the blkcnt number of blkksz-byte memory blocks (bytes)
	SIZE size = VTSZ_MPFMB(UNIT blkcnt, UNIT blkksz);	The size of fixed-size memory pool management area required to store the blkcnt number of blkksz-byte memory blocks (bytes)
	SIZE mpsz = TSZ_MPL(UNIT blkcnt, UNIT blkksz); *1	The size of variable-size memory pool area required to store the blkcnt number of blkksz-byte memory blocks (bytes)
	SIZE mpsz = VTSZ_MPLMB(UNIT sctnum); *2	The size of variable-size memory pool management area with the VTA_UNFRAGMENT attribute (bytes)
	TMAX_MAXSEM	Maximum number of resources in the semaphore (always 65535)

Table 4.1 Constants and Macros (cont)

File Name	Macro and Constants	Description
kernel_macro.h	TIC_NUME	Numerator of time tick cycle
	TIC_DENO	Denominator of time tick cycle
	TMAX_TPRI	Highest task priority
	TMAX_MPRI	Highest message priority
	VTCFG_TBR * ³	Indicates CFG_TBR 0: "Kernel does not manage" 1: "Only for service call" 2: "Task context"
	VTCFG_REGBANK * ³	Indicates the CFG_REGBANK setting 0: Register bank is not used (NOTUSE) 1: Register bank is used except NMI and UBC (ALL) 2: You select level to beused register bank (SELECT) 3: MCU has no register banks (NOBANK)
	VTCFG_BANKLVLnn * ³ (nn: a value from 01 to 15)	Indicates whether or not register banks are used with interrupts having interrupt level nn. 0: Register bank is not used. 1: Register bank is used. This definition is possible only when the CFG_REGBANK setting is other than NOBANK.
VTCFG_MPFMANAGE	Indicates CFG_MPFMANAGE 0: Places management tables in the memory pool (The same method as the previous version) 1: Places management table outside of the memory pool (Extended method)	
VTCFG_NEWMPL	Indicates CFG_NEWMPL 0: Conventional method 1: New method (reduced fragmentation and faster operation)	

Notes: 1. Definition differs depending on whether CFG_NEWMPL is selected
 2. Only when CFG_NEWMPL is selected
 3. Only in HI7000/4

(3) Header Files for ID Names (kernel_id.h, kernel_id_sys.h)

An ID name can be given to each object by the configurator. The configurator outputs the specified ID name to the ID name header file. Application can specify an object ID by using its ID name. For details, refer to section 5.4.4(1), kernel_id.h, kernel_id_sys.h.

```
wup_tsk(ID_main);
```

4.1.2 Header Files for Assembly Language

(1) itron.inc

itron.inc is a header file where the common ITRON specification definitions are described for assembly language. This file can be found in the hihead folder.

(2) kernel.inc

kernel.inc is a header file where the μ ITRON4.0 kernel specification definitions are described for assembly language. kernel.inc includes itron.inc. kernel.inc can be found in the hihead folder.

4.2 Handling the CPU Resources

4.2.1 SR Register

(1) SR.IMASK bits (Interrupt Mask Bit)

Refer to section 0,

Disabling Interrupts.

(2) SR.MD Bit (Processing mode bit) (SH-3, SH3-DSP, SH4AL-DSP, SH-4, SH-4A)

Application program must not clear MD bit. The MD bit of the SR specified in the following operations must be 1.

- def_inh, idef_inh, def_exc, idef_exc, vdef_trp, ivdef_trp
- Definition of interrupt handlers and CPU exception handlers (including TRAPA) in the configurator

(3) SR.RB Bit (Register bank bit) (SH-3, SH3-DSP, SH4AL-DSP, SH-4, SH-4A)

Application programs must not change bank 1 registers. And application programs must not set SR.RB bit to 1. The RB bit of the SR specified in the following operations must be 1.

- def_inh, idef_inh, def_exc, idef_exc, vdef_trp, ivdef_trp
- Definition of interrupt handlers and CPU exception handlers (including TRAPA) in the configurator

(4) SR.BL Bit (Exception block bit) (SH-3, SH3-DSP, SH4AL-DSP, SH-4, SH-4A)

In the exception block state, service calls must not be issued, unless the specific condition is specified.

When using this bit to disable interrupts, refer to section 0,

Disabling Interrupts.

(5) SR.DSP Bit (DSP operation mode bit) (SH3-DSP, SH4AL-DSP)

When using SH3-DSP or SH4AL-DSP, do the following operations.

(a) Checks CFG_DSP in the configurator. As a result, the SR.DSP bit when the task starts becomes 1.

(b) Interrupt handlers and CPU exception handlers

If the handler has DSP operation, the DSP bit of the SR specified in the following operations must be 1.

- def_inh, idef_inh, def_exc, idef_exc, vdef_trp, ivdef_trp
- Definition of interrupt handlers and CPU exception handlers (including TRAPA) in the configurator

However, refer to section 4.2.2, Cache Lock Function (SH-3, SH3-DSP), if using cache lock function of SH-3 and SH3-DSP.

(6) SR.CL Bit (Cache lock bit) (SH-3)

When using cache lock function on the microcomputer which has CL bit in the SR register, refer to section 4.2.2, Cache Lock Function (SH-3, SH3-DSP).

(7) SR.FD (FPU disable bit) (SH-4 and SH-4A)

The SR.FD bit must not be set in the application programs. In other words, the FPU disable exception of SH-4 cannot be used. The FD bit of the SR register must always be cleared to 0 in the following cases:

- def_inh, idef_inh, def_exc, idef_exc, vdef_trp, ivdef_trp
- Definition of interrupt handlers and CPU exception handlers (including TRAPA) in the configurator]

For further information, refer to Appendix G, Notes on FPU of SH2A-FPU, SH-4, SH4A.

4.2.2 Cache Lock Function (SH-3, SH3-DSP)

When using cache lock function, do the following operations. Note, the kernel does not control cache lock. Application program should control cache lock.

(1) Microcomputer which has LE (Lock enable) bit in the cache control register 2 (CCR2)

In the microcomputers of this type, cache lock function is effective when CCR2.LE bit is 1. The control of cache lock (enable and disable) is done by CCR.LE bit.

(2) Microcomputer which does not have LE (Lock enable) bit in the cache control register 2 (CCR2)

In the microcomputers of this type, cache lock function is effective when SR.DSP or SR.CL bit is 1. To maintain cache lock state, SR.DSP or SR.CL bit is always 1. It is necessary to do the following for that.

- (a) Checks CFG_DSP or CFG_CACLOC in the configurator. As a result, the SR.DSP or SR.CL bit when the task starts and kernel executes becomes 1.
- (b) For all interrupt handlers and CPU exception handlers (including TRAPA), the DSP or CL bit of the "Handler SR" which is specified at definition must be 1.
- (c) Application program must not clear SR.DSP or SR.CL bit.

If these operations are not satisfied, SR.DSP or SR.CL may be cleared. It means that cache lock state is canceled.

4.2.3 VBR Register

The VBR register is initialized at kernel initiation. Application programs must not change the VBR.

4.2.4 MMU (SH-3, SH3-DSP, SH4AL-DSP, SH-4, SH-4A)

The kernel does not control the MMU.

4.2.5 Acceptance of NMI while SR.BL = 1 (SH-3, SH3-DSP, SH4AL-DSP, SH-4, SH-4A)

There are some microcomputers which can set up by the interrupt controller whether an NMI which is generated in the state of SR.BL = 1 is accepted immediately or it is suspended until clearing SR.BL. When it is made a setup detected immediately, returning to normal operation of system after NMI interrupt handler is not guaranteed.

4.2.6 Nesting the Interrupts (SH-3, SH3-DSP, SH4AL-DSP, SH-4, SH-4A)

When the interrupts are nested for 64 times or more including NMI, normal system operation cannot be guaranteed. Make sure that no more than 64 interrupts are nested.

4.2.7 32-Bit Address Extension Mode (SH-4A)

When using 32-bit address extension mode, set up PMB so that behavior of P1 and P2 area becomes the same as 29-bit address mode before kernel initiation.

4.2.8 TBR Register (SH-2A, SH2A-FPU)

How to use the TBR register is specified through CFG_TBR in the configurator.

(1) Kernel does not manage

The kernel does not manage TBR.

(2) Only for service call

The TBR is used only for service calls. Service calls are accelerated.

The TBR is initialized by the kernel. If TBR is modified by the application, correct system operation cannot be guaranteed.

The TBR option and "#pragma tbr" of the compiler must not be used.

(3) Task context

Tasks can modify TBR. The initial value of TBR at task initiation is undefined.

The handlers other than tasks must guarantee the TBR value if the handlers modify TBR.

4.2.9 Register Banks (SH-2A, SH2A-FPU)

The SH-2A and SH2A-FPU processors provide register banks to accelerate interrupt response. How and whether the register banks are used is specifiable through the [Modification of Interrupt Information] dialog box in the configurator.

- (1) To use the register banks for all interrupts other than the NMI and UBC interrupts when the target MCU is equipped with register banks

Select [Register bank is used except NMI and UBC (ALL)] for CFG_REGBANK and specify the address of IBNR in [CFG_IBNR_ADR]. The kernel sets the IBNR value to 0x4000 during initialization (vsta_knel).

- (2) To select whether or not to use the register banks for interrupts with specific interrupt levels when the target MCU is equipped with register banks

Select [You select level to beused register bank (SELECT)] for CFG_REGBANK and select the interrupt levels from CFG_BANKLVL01 to CFG_BANKLVL15 with which the register banks are to be used. After that, specify the address of IBNR in [CFG_IBNR_ADR]. During initialization (vsta_knel), the kernel initializes the the IBNR value to 0xC000 and the IBCR value to a value that depends on the settings of CFG_BANKLVL01 to CFG_BANKLVL15.

- (3) To select non-usage of the register banks although the target MCU is equipped with register banks

Select [Register bank is not used (NOTUSE)] for CFG_REGBANK and specify the address of IBNR in [CFG_IBNR_ADR]. The kernel initializes the IBNR value to 0 during initialization (vsta_knel).

- (4) When the target MCU does not have register banks

If you are using an MCU that does not have register banks (i.e., the processor is not an SH-2A or SH2A-FPU), select [MCU has no register banks (NOBANK)] for CFG_REGBANK.

Note that the description method of interrupt handlers depends on the CFG_REGBANK setting. For details, refer to section 4.8, Interrupt Handlers.

4.3 Using SH2A-FPU, SH-4, or SH-4A

Be sure to refer to Appendix G, Notes on FPU of SH2A-FPU, SH-4, SH4A even when FPU is not used.

4.4 System Reserve

4.4.1 Reserved Name

External definition names beginning with `_kernel_`, `_KERNEL_`, and `hi_` are reserved for the kernel, and cannot be used in application programs written in C language.

4.4.2 Reserved TRAP (Only in HI7000/4)

The TRAPA #25 and #26 instructions are used by the HI7000/4 kernel. Application programs must not use these instructions.

4.5 Tasks

(1) Writing a Task in C Language

Figure 4.1 shows an example of writing a task as a function written in C language. For details, refer to the sample file `task.c`.

Use an `ext_tsk` or `exd_tsk` system call to end a task. If the task is returned without issuing `ext_tsk` or `exd_tsk`, `ext_tsk` is assumed to be issued and the same operation as when `ext_tsk` is issued is performed.

<pre>#include "kernel.h" #pragma noregsave(Task) void Task(VP_INT exinf) { /* task processing */ ext_tsk(); }</pre>	<pre>← #pragma noregsave can be used because the task function does not need to guarantee register contents. ← When a task is initiated by TA_ACT attribute or act_tsk, passes exinf specified at task creation as a parameter; when a task is initiated by sta_tsk, passes stacd specified by sta_tsk as a parameter. ← Uses an ext_tsk or exd_tsk service call to end a task. ← Calls ext_tsk automatically at the end of a task function.</pre>
-------------------------------------------------------------------------------------------------------------------------------	-------------------------------------------------------------------------------------------------------------------------------------------------------------------------------------------------------------------------------------------------------------------------------------------------------------------------------------------------------------------------------------------------------------------------------------------------------

Figure 4.1 Example of a C Language Task

(2) Rules on Using Registers

Tables 4.2 to 4.4 show rules on using registers for HI7000/4, HI7700/4, and HI7750/4.

Table 4.2 Rules on Using Registers in a Task (HI7000/4)

No	Registers	Use *1	End Conditions *2	Initial Value
1	PC	√		Task start address
2	SR	√	*3	H'00000000
3	R0 to R3	√		Undefined
4	R4	√		[Activated by TA_ACT attribute or act_tsk] exinf which is specified at task creation [Activated by sta_tsk] stacd which is specified by sta_tsk
5	R5 to R14, MACH, MACL, GBR	√		Undefined
6	R15	√	√	End address of stack area for the task
7	PR	√	√	Undefined
8	[SH2-DSP] DSR		*4	0 when attribute TA_COP0 is specified, or undefined in other cases
9	[SH2-DSP] RS, RE, MOD, A0, A0G, A1, A1G, M0, M1, X0, X1, Y0, Y1		*4	Undefined
10	[SH-2A, SH2A-FPU] TBR		*5	Undefined
11	[SH2A-FPU] FPSCR		*6	H'00040001
12	[SH2A-FPU] FPUL, FR0 to FR15		*6	Undefined

Notes: 1. These registers can be used. Note that some register contents cannot be guaranteed after service calls. For details, refer to section 3.2.3, Guarantee of Register Contents after Issuing Service Call.

2. When execution is returned from the entry function (RTS instruction), the contents of these registers must be the same as the value at initiation.
3. Except in the CPU-locked state, IMASK must be 0.
4. Only when the TA_COP0 attribute is specified.
5. Depends on CFG_TBR.
 - (1) "Kernel does not manage": The kernel does not operate TBR.
 - (2) "Only for service call": Do not modify TBR
 - (3) "Task context": Usable
6. Only when the TA_COP1 attribute is specified.

Table 4.3 Rules on Using Registers in a Task (HI7700/4)

No	Registers	Use *1	End Conditions *2	Initial Value
1	PC	√		Task start address
2	SR	√	*3	[Either CFG_DSP or CFG_CACLOC is checked] H'40001000 [Neither CFG_DSP nor CFG_CACLOC is checked] H'40000000
3	R0_BANK0 to R3_BANK0	√		Undefined
4	R4_BANK0	√		[Activated by TA_ACT attribute or act_tsk] exinf which is specified at task creation [Activated by sta_tsk] stacd which is specified by sta_tsk
5	R5_BANK0 to R7_BANK0, R8 to R14, MACH, MACL, GBR	√		Undefined
6	R15	√	√	End address of stack area for the task
7	PR	√	√	Undefined
8	[SH3-DSP, SH4AL-DSP] DSR		*4	0 when attribute TA_COP0 is specified, or undefined in other cases
9	[SH3-DSP, SH4AL-DSP] RS, RE, MOD, A0, A0G, A1, A1G, M0, M1, X0, X1, Y0, Y1		*4	Undefined

- Notes: 1. These registers can be used. Note that some register contents cannot be guaranteed after service calls. For details, refer to section 3.2.3, Guarantee of Register Contents after Issuing Service Call.
2. When execution is returned from the entry function (RTS instruction), the contents of these registers must be the same as the value at initiation.
3. DSP/CL must be 1 when at least one of CFG_DSP and CFG_CACLOC is checked. Except in the CPU-locked state, IMASK must be 0.
MD = 1, BL = 0, and RB = 0 are required.
4. Only when the TA_COP0 attribute is specified.

Table 4.4 Rules on Using Registers in a Task (HI7750/4)

No	Registers	Use *1	End Conditions *2	Initial Value
1	PC	√		Task start address
2	SR	√	*3	H'40000000
3	R0_BANK0 to R3_BANK0	√		Undefined
4	R4_BANK0	√		[Activated by TA_ACT attribute or act_tsk] exinf which is specified at task creation [Activated by sta_tsk] stacd which is specified by sta_tsk
5	R5_BANK0 to R7_BANK0, R8 to R14, MACH, MACL, GBR	√		Undefined
6	R15	√	√	End address of stack area for the task
7	PR	√	√	Undefined
8	[SH-4, SH-4A] FPSCR	√		H'00040001
9	[SH-4, SH-4A] FPUL		*4	Undefined
10	[SH-4, SH-4A] FR0_BANK0 to FR15_BANK0		*5	Undefined
11	[SH-4, SH-4A] FR0_BANK1 to FR15_BANK1		*6	Undefined

Notes: 1. These registers can be used. Note that some register contents cannot be guaranteed after service calls. For details, refer to section 3.2.3, Guarantee of Register Contents after Issuing Service Call.

2. When execution is returned from the entry function (RTS instruction), the contents of these registers must be the same as the value at initiation.
3. Except in the CPU-locked state, IMASK must be 0.
MD = 1, BL = 0, RB = 0, and FD = 0 are required.
4. Only when at least one of the TA_COP1 and TA_COP2 attributes is specified.
5. Only when the TA_COP1 attribute is specified.
6. Only when the TA_COP2 attribute is specified.

(3) Initial Contents of Task Management Information

Kernel management information is initialized when a task is initiated. The task management information items and their initialized contents are shown in table 4.5.

Table 4.5 Initialized Contents of Task Management Information

Item	Initialization Specification
Task base priority	The initial task priority specified at the task definition (itskpri)
Task current priority	The current task priority
Task wake-up request queues	0
Task suspend request nestings	0
Task event flag	0
Task exception processing	Disabled
Suspended exception factor	0
Task execution mode	0

(4) Creating a Task

Tasks can be created in the following ways:

- Tasks that use a dynamic stack or a stack allocated by application:
 - cre_tsk, icre_tsk, acre_tsk, or iacre_tsk service call
 - Defined initially by the configurator
- Tasks that use a static stack:
 - vscr_tsk service call
 - Defined initially by the configurator

4.6 Task Exception Processing Routines

(1) Writing a Task Exception Processing Routine

A task exception processing routine is normally written in C language, as shown in figure 4.2.

```
#include "kernel.h"
#pragma noregsave (Texrtn)           ← Since a task exception
                                     processing routine
                                     function does not need to
                                     guarantee the register,
                                     #pragma noregsave can be
                                     specified.

void Texrtn(TEXPTN texptn, VP_INT exinf) ← Passes exception factors
                                     and extended information
                                     as a parameter.
{
  /* Task exception processing routine */
}
```

Figure 4.2 Example of a C Language Task Exception Processing Routine

(2) Rules on Using Registers

Tables 4.6 to 4.8 show rules on using registers for HI7000/4, HI7700/4, and HI7750/4.

Table 4.6 Rules on Using Registers in a Task Exception Processing Routine (HI7000/4)

No	Registers	Use *1	End Conditions *2	Initial Value
1	PC	√		Task exception processing routine start address
2	SR	√	*3	0
3	R0 to R3	√		Undefined
4	R4	√		Task exception pattern
5	R5	√		Extended information (exinf) of the task exception processing routine
6	R6 to R14, MACH, MACL, GBR	√		Undefined
7	R15	√	√	R15 points to the task's stack area.
8	PR	√	√	Undefined
9	[SH2-DSP] DSR	*4		0 when attribute TA_COP0 is specified, or undefined in other cases
10	[SH2-DSP] RS, RE, MOD, A0, A0G, A1, A1G, M0, M1, X0, X1, Y0, Y1	*4		Undefined
11	[SH-2A, SH2A-FPU] TBR	*5	*5	*5
12	[SH2A-FPU] FPSCR	*6		H'00040001
13	[SH2A-FPU] FPUL, FR0 to FR15	*6		Undefined

- Notes:
1. These registers can be used. Note that some register contents cannot be guaranteed after service calls. For details, refer to section 3.2.3, Guarantee of Register Contents after Issuing Service Call.
 2. When execution is returned from the entry function (RTS instruction), the contents of these registers must be the same as the value at initiation.
 3. Except in the CPU-locked state, IMASK must be 0.
 4. Only when the TA_COP0 attribute is specified.
 5. Depends on CFG_TBR.
 - (1) "Kernel does not manage": The kernel does not operate TBR.
 - (2) "Only for service call": Do not modify TBR
 - (3) "Task context": When execution is returned from the task exception processing routine entry function (RTS instruction), the contents of TBR must be the same as the value at initiation. The initial value is the same as TBR of the task immediately before the task exception processing routine is started.
 6. Only when the TA_COP1 attribute is specified.

Table 4.7 Rules on Using Registers in a Task Exception Processing Routine (HI7700/4)

No	Registers	Use *1	End Conditions *2	Initial Value
1	PC	√		Task exception processing routine start address
2	SR	√	*3	H'40001000 when either CFG_DSP or CFG_CACLOC is selected, or H'40000000 when neither of them is selected
3	R0_BANK0 to R3_BANK0	√		Undefined
4	R4_BANK0	√		Task exception pattern
5	R5_BANK0	√		Extended information (exinf) of the task exception processing routine
6	R6_BANK0, R7_BANK0, R8 to R14, MACH, MACL, GBR	√		Undefined
7	R15	√	√	R15 points to the task's stack area.
8	PR	√	√	Undefined
9	[SH3-DSP, SH4AL-DSP] DSR	*4		0 when attribute TA_COP0 is specified, or undefined in other cases
10	[SH3-DSP, SH4AL-DSP] RS, RE, MOD, A0, A0G, A1, A1G, M0, M1, X0, X1, Y0, Y1	*4		Undefined

- Notes:
1. These registers can be used. Note that some register contents cannot be guaranteed after service calls. For details, refer to section 3.2.3, Guarantee of Register Contents after Issuing Service Call.
 2. When execution is returned from the entry function (RTS instruction), the contents of these registers must be the same as the value at initiation.
 3. DSP/CL must be 1 when at least one of CFG_DSP and CFG_CACLOC is checked. Except in the CPU-locked state, IMASK must be 0. MD = 1, BL = 0, and RB = 0 are required.
 4. Only when the TA_COP0 attribute is specified.

Table 4.8 Rules on Using Registers in a Task Exception Processing Routine (HI7750/4)

No	Registers	Use *1	End Conditions *2	Initial Value
1	PC	√		Task exception processing routine start address
2	SR	√	*3	H'40000000
3	R0_BANK0 to R3_BANK0	√		Undefined
4	R4_BANK0	√		Task exception pattern
5	R5_BANK0	√		Extended information (exinf) of the task exception processing routine
6	R6_BANK0, R7_BANK0, R8 to R14, MACH, MACL, GBR	√		Undefined
7	R15	√	√	R15 points to the task's stack area.
8	PR	√	√	Undefined
9	[SH-4, SH-4A] FPSCR	√		H'00040001
10	[SH-4, SH-4A] FPUL	*4		Undefined
11	[SH-4, SH-4A] FR0_BANK0 to FR15_BANK0	*5		Undefined
12	[SH-4, SH-4A] FR0_BANK1 to FR15_BANK1	*6		Undefined

- Notes:
1. These registers can be used. Note that some register contents cannot be guaranteed after service calls. For details, refer to section 3.2.3, Guarantee of Register Contents after Issuing Service Call.
 2. When execution is returned from the entry function (RTS instruction), the contents of these registers must be the same as the value at initiation.
 3. Except in the CPU-locked state, IMASK must be 0.
MD = 1, BL = 0, RB = 0, and FD = 0 are required.
 4. Only when at least one of the TA_COP1 and TA_COP2 attributes is specified.
 5. Only when the TA_COP1 attribute is specified.
 6. Only when the TA_COP2 attribute is specified.

(3) Defining a Task Exception Processing Routine

A task exception processing routine can be defined in the following ways:

- def_tex or idef_tex service call
- Defined initially by the configurator

4.7 Extended Service Call Routines

(1) Writing an Extended Service Call Routine

An extended service call routine is normally written in C language, as shown in figure 4.3.

```
#include "kernel.h"
ER_UINT Svcrtm(VP_INT par1,VP_INT par2)  ←Parameters specified by
                                         cal_svc are passed to the
                                         extended service call
                                         routine.
{
  /* Extended service call routine */
  return E_OK;                            ←Passes the return value
                                         to the caller
}
```

Figure 4.3 Example of a C Language Extended Service Call Routine

(2) Rules on Using Registers in Extended Service Call Routine

An extended service call routine is called by issuing the cal_svc or ical_svc service call in the same way as a normal function call. Therefore, an extended service call routine can use registers in the same way as normal C language functions. For details, refer to SuperH™ RISC engine C/C++ Compiler User's Manual.

Parameters 1 to 4 specified by cal_svc are stored in the R4 to R7 registers. Note that the task issuing cal_svc or ical_svc determines whether or not the DSP and FPU registers can be used in an extended service call routine.

(3) Defining an Extended Service Call Routine

An extended service call routine can be defined in the following ways:

- def_svc or ideo_svc service call
- Defined initially by the configurator

4.8 Interrupt Handlers

There are two types of interrupt handlers. One is "Normal interrupt handler", and another is "Direct interrupt handler" for HI7000/4. The interrupt response of the direct interrupt handler is better than the normal interrupt handler.

4.8.1 Normal Interrupt Handler

A normal interrupt handler is initiated via the entrance and exit processing routine of the kernel when an interrupt occurs.

When the HI7000/4 is used, the interrupts with a level higher than the kernel interrupt mask level (CFG_KNLMSKLVL) must be written and defined as the direct interrupt handler (including NMI). If these handlers are written and defined as the normal interrupt handler, normal system operation cannot be guaranteed.

(1) Writing a Normal Interrupt Handler

A normal interrupt handler is written in C language, as shown in figure 4.4.

```
#include "kernel.h"
#pragma noregsave(Inh)      ←When SH-2A or SH2A-FPU is used and
                             CFG_REGBANK is checked, this statement
                             can be used because the handler does
                             not have to guarantee general registers.

void Inh(void)              ←An interrupt handler is defined as void.
{
    /* Interrupt handler processing */
}
```

Figure 4.4 Example of a C Language Normal Interrupt Handler

(2) Rules on Using Registers in a Normal Interrupt Handler

Tables 4.9 to 4.11 show rules on using registers for HI7000/4, HI7700/4, and HI7750/4.

Table 4.9 Rules on Using Registers in a Normal Interrupt Handler (HI7000/4)

No	Registers	Use *1	End Conditions *2	Initial Value
1	PC	√		Interrupt handler start address
2	SR	√	*3	IMASK: Interrupt level Other bits: Same as before interrupt.
3	R0 to R7	√		Undefined
4	R8 to R14, MACH, MACL, GBR	√	√ *4	Undefined
5	R15	√	√	R15 points to the interrupt handler stack area. The kernel changes the stack pointer to the interrupt handler stack area at interrupt. All interrupt handlers use the same stack area. The size of the interrupt handler stack area is defined by CFG_IRQSTKSZ. Note that the size of the interrupt handler stack must be calculated carefully considering interrupt nestings. For details, refer to appendix C.7, Interrupt Handler Stacks.
6	PR	√	√	Undefined
7	[SH2-DSP] DSR, RS, RE, MOD, A0, A0G, A1, A1G, M0, M1, X0, X1, Y0, Y1	√	√	Undefined
8	[SH-2A, SH2A-FPU] TBR	*5	*5	*5
9	[SH2A-FPU] FPSCR	√	√	Undefined
10	[SH2A-FPU] FR0 to FR11	√	√	Undefined
11	[SH2A-FPU] FPUL, FR12 to FR15	√	√	Undefined

- Notes:
- These registers can be used. Note that some register contents cannot be guaranteed after service calls. For details, refer to section 3.2.3, Guarantee of Register Contents after Issuing Service Call.
 - When execution is returned from the entry function (RTS instruction), the contents of these registers must be the same as the value at initiation.
 - IMASK bits must not be lower than the current interrupt level.
 - When the SH-2A or SH2A-FPU is used and CFG_REGBANK is selected, the end condition is not required.
 - Depends on CFG_TBR.
 - "Kernel does not manage": The kernel does not operate TBR.
 - "Only for service call": Do not modify TBR

(3) "Task context": When execution is returned from an interrupt handler function (RTS instruction), the contents of TBR must be the same as the value at initiation. The initial value is undefined.

Table 4.10 Rules on Using Registers in a Normal Interrupt Handler (HI7700/4)

No	Registers	End Conditions		Initial Value
		Use *1	*2	
1	PC	√		Interrupt handler start address
2	SR	√	*3	The value which is specified at the definition.
3	R0_BANK0 to R7_BANK0	√		Undefined
4	R8 to R14, MACH, MACL, GBR	√	√	Undefined
5	R15	√	√	R15 points to the interrupt handler stack area. The kernel changes the stack pointer to the interrupt handler stack area at interrupt. All interrupt handlers use the same stack area. The size of the interrupt handler stack area is defined by CFG_IRQSTKSZ. Note that the size of the interrupt handler stack must be calculated carefully considering interrupt nestings. For details, refer to appendix C.7, Interrupt Handler Stacks.
6	PR	√	√	Undefined
7	[SH3-DSP, SH4AL-DSP] DSR, RS, RE, MOD, A0, A0G, A1, A1G, M0, M1, X0, X1, Y0, Y1	√	√	Undefined

- Notes:
- These registers can be used. Note that some register contents cannot be guaranteed after service calls. For details, refer to section 3.2.3, Guarantee of Register Contents after Issuing Service Call.
 - When execution is returned from the entry function (RTS instruction), the contents of these registers must be the same as the value at initiation.
 - IMASK bits must not be lower than the current interrupt level.
DSP/CL must be 1 when at least one of CFG_DSP and CFG_CACLOC is checked.
MD must be 1.

Table 4.11 Rules on Using Registers in a Normal Interrupt Handler (HI7750/4)

No	Registers	Use *1	End Conditions *2	Initial Value
1	PC	√		Interrupt handler start address
2	SR	√	*3	The value which is specified at the definition.
3	R0_BANK0 to R7_BANK0	√		Undefined
4	R8 to R14, MACH, MACL, GBR	√	√	Undefined
5	R15	√	√	R15 points to the interrupt handler stack area. The kernel changes the stack pointer to the interrupt handler stack area at interrupt. All interrupt handlers use the same stack area. The size of the interrupt handler stack area is defined by CFG_IRQSTKSZ. Note that the size of the interrupt handler stack must be calculated carefully considering interrupt nestings. For details, refer to appendix C.7, Interrupt Handler Stacks.
6	PR	√	√	Undefined
7	[SH-4, SH-4A] FPSCR	√		Undefined
8	[SH-4, SH-4A] FPUL	√	√	Undefined
9	[SH-4, SH-4A] FR0_BANK0 to FR15_BANK0	√	√	Undefined
10	[SH-4, SH-4A] FR0_BANK1 to FR15_BANK1	√	√	Undefined

Notes: 1. These registers can be used. Note that some register contents cannot be guaranteed after service calls. For details, refer to section 3.2.3, Guarantee of Register Contents after Issuing Service Call.

2. When execution is returned from the entry function (RTS instruction), the contents of these registers must be the same as the value at initiation.
3. IMASK bits must not be lower than the current interrupt level.
MD must be 1. FD must be 0.

(3) Writing a Normal Interrupt Handler in C Language Using the DSP

To use the DSP in an interrupt handler, refer to section 4.13, Using the DSP in Programs (for HI7000/4 and HI7700/4 only).

(4) Using the IRL Interrupt

In an IRL interrupt, two different interrupt causes are assigned to one vector. When using both of these causes, the normal interrupt handler must be modified, as shown in figure 4.5.

```

#include "kernel.h"
#define I_HILEVEL15          ←Higher level
void vec071_handler14(void) ←Executes IRL14 processing.
{
    /* IRL14 interrupt processing */
}
void vec071_handler15(void) ←Executes IRL15 processing.
{
    /* IRL14 interrupt processing */
}
}
void vec071(void)           ←Defines vec071() as a
{                           normal interrupt handler
    if ((get_imask()) == I_HILEVEL)
        vec071_handler15();
    else
        vec071_handler14();
}

```

Figure 4.5 Example of a C Language Interrupt Handler Using IRL Interrupt

(5) Defining a Normal Interrupt Handler

A normal interrupt handler can be defined in the following ways:

- def_inh or idef_inh service call
- Defined initially by the configurator

(6) Notes on the NMI (HI7700/4, HI7750/4)

NMI re-entry can be allowed or not allowed in the following ways:

- To not allow the NMI re-entry
The BL bit of the SR must be set to 1 at the initiation of the handler, which is specified when the NMI interrupt handler is defined, and must not be cleared by the NMI interrupt handler. Since the NMI interrupt handler is executed while the BL bit of SR is 1, the exception of the handler (including TLB miss) must not occur.
- To allow the NMI re-entry
The BL bit of the SR must be cleared to 0 at the initiation of the handler, which is specified when the NMI interrupt is defined, and the BL bit can be cleared by the NMI interrupt. Note, however, that since re-entry of NMI occurs in this case, a larger stack size is required compared to that when the NMI re-entry is not allowed.

4.8.2 Direct Interrupt Handler (HI7000/4)

A direct interrupt handler supported by HI7000/4 is initiated by the CPU without kernel intervention when an interrupt occurs. In addition, interrupt handlers with interrupt levels higher than the kernel interrupt mask level (CFG_KNLMSKLV) must be written and defined as direct interrupt handlers (including NMI). If these interrupts are written and defined as the normal interrupt handlers, normal system operation cannot be guaranteed.

Note that HI7700/4 and HI7750/4 do not support direct interrupt handlers.

(1) Writing a Direct Interrupt Handler

A direct interrupt handler is written in C language, as shown in figure 4.6.

```
#include "kernel.h"
#define stkksz 512 (1)
VW stk[stkksz / sizeof(VW)];
static const VP p_stk=(VP)&stk[stkksz/sizeof(VW)]; (2)
#pragma interrupt(DirectInh(sp=p_stk,tn=25)) (3)
void DirectInh(void) (4)
{
    /* Interrupt handler processing */
}
```

Figure 4.6 Example of a C Language Direct Interrupt Handler

Descriptions of Figure 4.6:

- (1) Allocate a stack area for the interrupt handler.

The handler except NMI must switch stacks in order to avoid overflow of the interrupted program's stack. Interrupt handlers of the same interrupt level can share a stack. Note, however, that NMI interrupt handler cannot use its dedicated stack.
- (2) Initial stack pointer defined as const
- (3) The interrupt handler function is declared as an interrupt function by using #pragma interrupt statement. Specify the following items,
 - (a) "sp=" (Switching stack)

Specify the variable defined in (2) when the stack is switched.
 - (b) "tn=" (Return by TRAPA)

For interrupt handlers with priority levels equal to or lower than the kernel interrupt mask level (CFG_KNLMSKLVL), "tn=" must be specified. For details, see table 4.12.
 - (c) "resbank" (Restore bank register)

When the SH-2A or SH2A-FPU is in use and register banks are used with interrupts, "resbank" must be specified. For details, see table 4.12.
- (4) Write the interrupt handler as a void-type function.

Table 4.12 "tn=" and "resbank" (HI7000/4)

CFG_REGBANK	Usage of Register Banks	Interrupt Level	"tn="	"resbank"
NOBANK or NOTUSE	—	Higher than CFG_KNLMSKLVL	None	None
		Equal to or lower than CFG_KNLMSKLVL	"tn=25" or "tn=26"*2	
ALL or SELECT	Interrupt sources with which register banks are used*1	Higher than CFG_KNLMSKLVL	None	None
		Equal to or lower than CFG_KNLMSKLVL	"tn=26"	
	Interrupt sources with which register banks are not used*1	Higher than CFG_KNLMSKLVL	None	"resbank"
		Equal to or lower than CFG_KNLMSKLVL	"tn=25"	

Notes: 1. Register banks are never used with the NMI and UBC interrupts. Register banks are used with all other interrupt sources when [ALL] has been selected for CFG_REGBANK. When [SELECT] has been selected for CFG_REGBANK, register banks are only used with those sources having interrupt levels for which the corresponding CFG_BANKLVL?? has been selected. Otherwise, register banks are not used with interrupt sources for which this is not the case.

2. The operation is the same in both cases.

(2) Rules for Using Registers in a Direct Interrupt Handler

Table 4.13 shows rules on using registers in a direct interrupt handler, and figure 4.7 shows an example of a direct interrupt handler written in assembly language.

Table 4.13 Rules for Using Registers in a Direct Interrupt Handler (HI7000/4)

No	Registers	Use *1	End Conditions *2	Initial Value
1	PC	√		Interrupt handler start address
2	SR	√	*3	IMASK: Interrupt level Other bits: Same as before interrupt
3	R0 to R14, MACH, MACL, GBR	√	√ *4	Undefined
4	R15	√	√	R15 points to the stack area for the interrupted program. [Interrupts other than NMI] When an interrupt occurs, the stack used by the task prior to an interrupt must be switched to the interrupt handler-specific stack to avoid task stack overflow. Otherwise, the task stack may overflow. Direct interrupt handlers of the same interrupt level can share that stack since such interrupt handlers do not use the stack simultaneously. When the stack is shared by direct interrupt handlers of the same interrupt level, the stack size must be defined considering the largest stack size used among the direct interrupt handlers. The direct interrupt handler can use 4 bytes of stack used by the previous task. [In case of NMI] Since the NMI interrupt handler has the possibility to re-enter, the stack must not be switched. Since the NMI interrupt handler uses the stack at the point of the NMI occurrence, the stack size to be used by the NMI interrupt handler must be added to the stacks for the tasks and the interrupt handler
5	PR	√	√ *4	Undefined
6	[SH2-DSP] DSR, RS, RE, MOD, A0, A0G, A1, A1G, M0, M1, X0, X1, Y0, Y1	√	√	Undefined

Table 4.13 Rules for Using Registers in a Direct Interrupt Handler (cont)

No	Registers	End Conditions		Initial Value
		Use *1	*2	
7	[SH-2A, SH2A-FPU] TBR	*5	*5	*5
8	[SH2A-FPU] FPSCR, FPUL、FR0 to FR15	√	√	Undefined

- Notes:
- These registers can be used. Note that some register contents cannot be guaranteed after service calls. For details, refer to section 3.2.3, Guarantee of Register Contents after Issuing Service Call.
 - When execution is returned from the entry function (RTE or TRAPA instruction), the contents of these registers must be the same as the value at initiation.
 - IMASK bits must not be lower than the current interrupt level.
 - In the case of the SH-2A or SH2A-FPU processors, the end condition is not necessary when register banks are used with interrupts.
 - Depends on CFG_TBR.
 - "Kernel does not manage": The kernel does not operate TBR.
 - "Only for service call": Do not modify TBR.
 - "Task context": When execution is returned from an interrupt handler function (RTS instruction), the contents of TBR must be the same as the value at initiation. The initial value is undefined.

```

.INCLUDE "kernel.inc"
.SECTION B_hirqstk, DATA, ALIGN=4 ←Defines the stack used by
.RES.L 128                          the interrupt handler.
_Stk:                                ←Assigns symbol _Stk to the
.SECTION P_ISR, CODE, ALIGN=4       end address of the stack.
.EXPORT _DirectInh
_DirectInh:                          ←Start address of the
MOV.L R0,@-R15                       interrupt handler.
                                      ←Saves the contents of R0 to
MOV.L #_Stk,R0                       the stack of the program
                                      that was interrupted.
                                      ←Saves the address pointed
MOV.L R15,@-R0                       to by the stack pointer
MOV.L R0,R15                          to the stack used by the
                                      interrupt handler.
MOV.L R1,@-R15                       ←Saves the contents of
                                      registers (including the
                                      DSP) used by the handler
                                      to stack.
;      ....
; Interrupt handler process
;      ....
                                      ←Restores the register
                                      contents after completing
                                      handler execution.
MOV.L @R15+,R1
MOV.L @R15+,R15                       ←Restores the address
                                      pointed to by the stack
                                      pointer.
MOV.L @R15+,R0                       ←Restores the contents of
                                      R0.
<End instruction>                    ← See table 4.14.
.POOL
.END

```

Figure 4.7 Example of an Assembly Language Direct Interrupt Handler

Table 4.14 End Instructions for Direct Interrupt Handlers (HI7000/4)

CFG_REGBANK	Use of Register Banks	Interrupt Level	End Instruction
NOBANK or NOTUSE	—	Higher than CFG_KNLMSKLVL	RTE
		Equal to or lower than CFG_KNLMSKLVL	TRAPA #D'25 or TRAPA #D'26*2
ALL or SELECT	Interrupt sources with which register banks are used*1	Higher than CFG_KNLMSKLVL	None
		Equal to or lower than CFG_KNLMSKLVL	TRAPA #D'26
	Interrupt sources with which register banks are not used*1	Higher than CFG_KNLMSKLVL	RESBANK RTE*3
		Equal to or lower than CFG_KNLMSKLVL	TRAPA #D'25

- Notes: 1. Register banks are never used with the NMI and UBC interrupts. Register banks are used with all other interrupt sources when [ALL] has been selected for CFG_REGBANK. When [SELECT] has been selected for CFG_REGBANK, register banks are only used with those sources having interrupt levels for which the corresponding CFG_BANKLVL?? has been selected. Otherwise, register banks are not used with interrupt sources for which this is not the case.
2. The operation is the same in both cases.
3. Both instructions must be included, in the order given above.

(3) Writing a Direct Interrupt Handler Using the DSP

To use the DSP in a direct interrupt handler, refer to section 4.13, Using the DSP in Programs (for HI7000/4 and HI7700/4 only).

(4) Defining a Direct Interrupt Handler

A direct interrupt handler can be defined in either of the following ways.

- By making a def_inh or idef_inh service call
- By specification in the configurator

(5) Using the IRL Interrupt

In an IRL interrupt, two different interrupt causes are assigned to one vector. When using both of these causes, the direct interrupt handler must be modified as shown in figure 4.8.

- Creating an interrupt handler in C language

Create the main process as a normal C function, as shown in figure 4.8. In assembly language, create the interface routine, which calls the C function when an interrupt occurs, as shown in figure 4.9. When defining interrupt handlers by the configurator, specify the interface routine address as the interrupt handler address.

Section4 Application Program Creation

```
#include "kernel.h"
void vec071_handler14(void)           ←Describes the program as a
                                      usual void-type function.
{
    /* IRL14 interrupt processing */
}

void vec071_handler15(void)         ←Describes the program as a
                                      usual void-type function.
{
    /* IRL15 interrupt processing */
}
```

Figure 4.8 Example of a C Language IRL Direct Interrupt Handler Main Processing Routine

```
.EXPORT _Vec071                       ←Externally defines the
                                      interface routine.
.IMPORT _Vec071_Handler14             ←Externally references the
                                      IRL14 interrupt handler
                                      main function.
.IMPORT _Vec071_Handler15             ←Externally references the
                                      IRL15 interrupt handler
                                      main function.

.SECTION B_hiiqrstk,DATA,ALIGN=4
.RES.L 128
_Stk15:                               ←Defines the interrupt
                                      handler stack for IRL15.
                                      ←Assigns symbol _Stk15 to
                                      the end address of the IRL15
                                      stack.

.RES.L 128
_Stk14:                               ←Defines the interrupt
                                      handler stack for IRL14.
                                      ←Assigns symbol _Stk14 to
                                      the end address of the IRL14
                                      stack.
```

Figure 4.9 Example of an Assembly Language IRL Direct Interrupt Handler Interface Routine

```

.SECTION P_ISR, CODE, ALIGN=4
I_HILEVEL .equ H'F0>>1      ←(SR bit location of high
                             level)>>1
I_BITMASK .equ H'F0        ←Defines bit mask of SR.I
                             field.
_Vec071:                    ←Interface routine.
    MOV.L R0, @-R15         ←Saves the contents of R0 to
                             the stack of the program
                             that was interrupted.

    STC SR, R0             ←Checks the level of the
    AND #I_BITMASK, R0    interrupt and determines
    SHLR R0                which stack to switch to
    CMP/EQ #I_HILEVEL, R0 and the address for the
    BF IRL14              main process.
IRL15:                      ←Process for IRL15
    MOV.L #_Stk15, R0     ←Saves the address pointed
    MOV.L R15, @-R0       to by the stack pointer to
                             the stack of IRL15.

    MOV R0, R15           ←Switches from the stack
                             pointer to the stack for
                             IRL15.

    MOV.L #_Vec071_Handler15, R0 ←Sets the address of IRL15
                             main process to R0.

CONTINUE:
    MOV.L R1, @-R15       ←Saves the contents of the
    MOV.L R2, @-R15       registers used by the main
    MOV.L R3, @-R15       process according to the C
    MOV.L R4, @-R15       language function calling
    MOV.L R5, @-R15       rules. When the handler
    STS.L PR, @-R15       uses the DSP, the
    MOV.L R6, @-R15       contents of the DSP
    STS.L MACL, @-R15     registers must be saved.
    MOV.L R7, @-R15
    STS.L MACH, @-R15
    JSR @R0                ←Calls the main process.
    NOP
    LDS.L @R15+, MACH     ←Restores the contents of
    MOV.L @R15+, R7       the registers.

```

Figure 4.9 Example of an Assembly Language IRL Direct Interrupt Handler Interface Routine (cont)

LDS.L	@R15+,MACH	
MOV.L	@R15+,R6	
LDS.L	@R15+,PR	
MOV.L	@R15+,R5	
MOV.L	@R15+,R4	
MOV.L	@R15+,R3	
MOV.L	@R15+,R2	
MOV.L	@R15+,R1	
MOV.L	@R15+,R15	←Restores the address pointed to by the stack pointer.
MOV.L	@R15+,R0	←Restores the contents of R0.
TRAPA	#D'25	←An interrupt handler with a level equal to or lower than the kernel interrupt mask level completes execution with TRAPA #25.
;	RTE	←An interrupt handler with a level higher than the kernel interrupt mask level completes execution with RTE.
;	NOB	
IRL14:		←Process for IRL14.
MOV.L	#_Stk14,R0	←Saves the address pointed to by the stack pointer to the stack of IRL14.
MOV.L	R15,@-R0	
MOV	R0,R15	←Switches from the stack pointer to the stack for IRL14.
BRA	CONTINUE	
MOV.L	#_Vec071_Handler14,R0	←Sets the address of IRL14 main process to R0.
.POOL		
.END		

Figure 4.9 Example of an Assembly Language IRL Direct Interrupt Handler Interface Routine (cont)

- Creating an interrupt handler in assembly language

Refer to the above example, write a handler that performs the necessary processes after switching to the appropriate stack for the interrupt level, and then switches back to the original stack.

4.9 CPU Exception Handler (Including TRAPA Instruction Exception)

If an exception occurs, a CPU exception handler is initiated via the entrance and exit process of the kernel.

(1) Writing a CPU Exception Handler

A CPU exception handler (including the TRAPA instruction exception) can be defined in the same way as normal interrupt handlers. For details, refer to section 4.8.1, Normal Interrupt Handler.

(2) Rules for Using Registers in a CPU Exception Handler

Tables 4.15 to 4.17 show rules on using registers for HI7000/4, HI7700/4, and HI7750/4.

Table 4.15 Rules on Using Registers in a CPU Exception Handler (HI7000/4)

No	Registers	End Conditions		Initial Value
		Use *1	*2	
1	PC	√		CPU exception handler start address
2	SR	√		Same as before CPU exception.
3	R0 to R7	√		Undefined
4	R8 to R14, MACH, MACL, GBR	√	√	Same as before CPU exception.
5	R15	√	√	R15 points to the stack area for the program which generates exception. As a CPU exception handler may re-enter, the CPU exception handler uses the stack used by the previous program. A CPU exception handler does not use its own stack.
6	PR	√	√	Undefined
7	[SH2-DSP] DSR, RS, RE, MOD, A0, A0G, A1, A1G, M0, M1, X0, X1, Y0, Y1	√	√	Same as before CPU exception.
8	[SH-2A, SH2A-FPU] TBR	*3	*3	*3
9	[SH2A-FPU] FPSCR	√	√	Same as before CPU exception.
10	[SH2A-FPU] FR0 to FR11	√	√	Same as before CPU exception.
11	[SH2A-FPU] FPUL, FR12 to FR15	√	√	Same as before CPU exception.

Notes: 1. These registers can be used. Note that some register contents cannot be guaranteed after service calls. For details, refer to section 3.2.3, Guarantee of Register Contents after Issuing Service Call.

2. When execution is returned from the entry function (RTS instruction), the contents of these registers must be the same as the value at initiation.

3. Depends on CFG_TBR.

(1) "Kernel does not manage": The kernel does not operate TBR.

(2) "Only for service call": Do not modify TBR

(3) "Task context": When execution is returned from an interrupt handler function (RTS instruction), the contents of TBR must be the same as the value at initiation. The initial value is the same as before CPU exception.

Table 4.16 Rules on Using Registers in a CPU Exception Handler (HI7700/4)

No	Registers	Use *1	End Conditions *2	Initial Value
1	PC	√		CPU exception handler start address
2	SR	√	*3	IMASK bits: Same as before exception Other bits: The value which is specified at the definition.
3	R0_BANK0 to R7_BANK0	√		Undefined
4	R8 to R14, MACH, MACL, GBR	√	√	Same as before CPU exception.
5	R15	√	√	R15 points to the stack area for the program which generates exception. As a CPU exception handler may re-enter, the CPU exception handler uses the stack used by the previous program. A CPU exception handler does not use its own stack.
6	PR	√	√	Undefined
7	[SH3-DSP, SH4AL-DSP] DSR, RS, RE, MOD, A0, A0G, A1, A1G, M0, M1, X0, X1, Y0, Y1	√	√	Same as before CPU exception.

- Notes:
1. These registers can be used. Note that some register contents cannot be guaranteed after service calls. For details, refer to section 3.2.3, Guarantee of Register Contents after Issuing Service Call.
 2. When execution is returned from the entry function (RTS instruction), the contents of these registers must be the same as the value at initiation.
 3. DSP/CL must be 1 when at least one of CFG_DSP and CFG_CACLOC is checked. MD must be 1.

Table 4.17 Rules on Using Registers in a CPU Exception Handler (HI7750/4)

No	Registers	Use *1	End Conditions *2	Initial Value
1	PC	√		CPU exception handler start address
2	SR	√	*3	IMASK bits: Same as before exception Other bits: The value which is specified at the definition.
3	R0_BANK0 to R7_BANK0	√		Undefined
4	R8 to R14, MACH, MACL, GBR	√	√	Same as before CPU exception.
5	R15	√	√	R15 points to the stack area for the program which generates exception. As a CPU exception handler may re-enter, the CPU exception handler uses the stack used by the previous program. A CPU exception handler does not use its own stack.
6	PR	√	√	Undefined
7	[SH-4, SH-4A] FPSCR	√		Same as before CPU exception.
8	[SH-4, SH-4A] FPUL	√	√	Same as before CPU exception.
9	[SH-4, SH-4A] FR0_BANK0 to FR15_BANK0	√	√	Same as before CPU exception.
10	[SH-4, SH-4A] FR0_BANK1 to FR15_BANK1	√	√	Same as before CPU exception.

- Notes:
1. These registers can be used. Note that some register contents cannot be guaranteed after service calls. For details, refer to section 3.2.3, Guarantee of Register Contents after Issuing Service Call.
 2. When execution is returned from the entry function (RTS instruction), the contents of these registers must be the same as the value at initiation.
 3. MD must be 1. FD must be 0.

(3) Contents of Stack at Initiation

When a CPU exception occurs, the kernel saves the register contents in the stack. When execution is returned from a CPU exception handler, the kernel restores these register contents from the stack.

(a) HI7000/4

Stack pointer (R15) ->	R7 at CPU exception	0
	R6 at CPU exception	+4
	R5 at CPU exception	+8
	R4 at CPU exception	+12
	R3 at CPU exception	+16
	R2 at CPU exception	+20
	R1 at CPU exception	+24
	R0 at CPU exception	+28
	PR at CPU exception	+32
	PC at CPU exception	+36
	SR at CPU exception	+40
Stack pointer before -> CPU exception	Stack before CPU exception	+44

(b) HI7700/4

Stack pointer (R15) ->	R7_BANK0 at CPU exception	0
	R6_BANK0 at CPU exception	+4
	R5_BANK0 at CPU exception	+8
	R4_BANK0 at CPU exception	+12
	R3_BANK0 at CPU exception	+16
	R2_BANK0 at CPU exception	+20
	R1_BANK0 at CPU exception	+24
	R0_BANK0 at CPU exception	+28
	PR at CPU exception	+32
	PC (SPC) at CPU exception	+36
	SR (SSR) at CPU exception	+40
Stack pointer before --> CPU exception	Stack before CPU exception	+44

Section4 Application Program Creation

(c) HI7750/4

Stack pointer (R15) ->

R7_BANK0 at CPU exception	0
R6_BANK0 at CPU exception	+4
R5_BANK0 at CPU exception	+8
R4_BANK0 at CPU exception	+12
R3_BANK0 at CPU exception	+16
R2_BANK0 at CPU exception	+20
R1_BANK0 at CPU exception	+24
R0_BANK0 at CPU exception	+28
PR at CPU exception	+32
FPSCR at CPU exception	+36
PC (SPC) at CPU exception	+40
SR (SSR) at CPU exception	+44
Stack before CPU exception	+48

Stack pointer before -->
CPU exception

(4) Writing a CPU Exception Handler in C Language Using the DSP

To use the DSP in a CPU exception handler, refer to section 4.13, Using the DSP in Programs (for HI7000/4 and HI7700/4 only).

(5) Defining a CPU Exception Handler

A CPU exception handler can be defined in the following ways:

- `def_exc` or `idef_exc` service call (CPU exception handlers other than TRAPA)
- `vdef_trp` or `ivdef_trp` service call (CPU exception handlers caused by TRAPA)
- Defined initially by the configurator

4.10 Time Event Handlers and Initialization Routine

(1) Writing Time Event Handlers and Initialization Routine

Time event handlers and initialization routine can be defined as regular C language functions.

Figure 4.10 shows an example of a cyclic handler, an alarm handler, and an initialization routine. Figure 4.11 shows an example of an overrun handler written in C language.

These handlers are executed in non-task context.

```
#include "kernel.h"
void Handler(VP_INT exinf)      ←Passes exinf specified at definition
                               as a parameter
{
    /* Handler processing */
}
```

Figure 4.10 Example of a C Language Cyclic Handler, Alarm Handler, and Initialization Routine

```
#include "kernel.h"
void Overhdr (ID tskid, VP_INT exinf)  ←Passes tskid indicating the
                                       initiation factor and exinf
                                       for the task
{
    /* Handler processing */
}
```

Figure 4.11 Example of a C Language Overrun Handler

(2) Rules for Using Registers in Time Event Handlers and Initialization Routine

Tables 4.18 to 4.20 show rules on using registers for HI7000/4, HI7700/4, and HI7750/4.

Table 4.18 Rules for Using Registers in Time Event Handler and Initialization Routine (HI7000/4)

No	Registers	Use *1	End Conditions *2	Initial Value
1	PC	√		Handler/Routine start address
2	SR	√	*3	IMASK: Time event handler Timer interrupt level (CFG_TIMINTLVL) Initialization routine Kernel interrupt mask level (CFG_KNLMSKLVL) Other bits: Undefined.
3	R0 to R3	√		Undefined
4	R4	√		[Cyclic/Alarm handler, Initialization routine] Extended information (exinf) [Overrun handler] Target task ID
5	R5	√		[Cyclic/Alarm handler, Initialization routine] Undefined [Overrun handler] Extended information (exinf) for the task
6	R6 to R7	√		Undefined
7	R8 to R14, MACH, MACL, GBR	√	√	Undefined.
8	R15	√	√	R15 points to appropriate stack area.
9	PR	√	√	Undefined
10	[SH2-DSP] DSR, RS, RE, MOD, A0, A0G, A1, A1G, M0, M1, X0, X1, Y0, Y1	√	√	Undefined
11	[SH-2A, SH2A-FPU] TBR	*4	*4	*4
12	[SH2A-FPU] FPSCR	√	√	Undefined
13	[SH2A-FPU] FR0 to FR11	√	√	Undefined
14	[SH2A-FPU] FPUL, FR12 to FR15	√	√	Undefined

Notes: 1. These registers can be used. Note that some register contents cannot be guaranteed after service calls. For details, refer to section 3.2.3, Guarantee of Register Contents after Issuing Service Call.

2. When execution is returned from the entry function (RTS instruction), the contents of these registers must be the same as the value at initiation.

3. IMASK bits must not be lower than the value at initiation. And IMASK bits must be the same as initial value when execution is returned from the handler
4. Depends on CFG_TBR.
 - (1) "Kernel does not manage": The kernel does not operate TBR.
 - (2) "Only for service call": Do not modify TBR
 - (3) "Task context": When execution is returned from an interrupt handler function (RTS instruction), the contents of TBR must be the same as the value at initiation. The initial value is undefined.

Table 4.19 Rules for Using Registers in Time Event Handler and Initialization Routine (HI7700/4)

No	Registers	Use *1	End Conditions *2	Initial Value
1	PC	√		CPU exception handler start address
2	SR	√	*3	IMASK bits: Same as before exception MD = 1, BL = 0, RB = 0 DSP/CL: When at least one of CFG_DSP and CFG_CACLOC is checked. DSP/CL is 1, otherwise DSP/CL is 0. Other bits: Undefined
3	R0 to R3	√		Undefined
4	R4	√		[Cyclic/Alarm handler, Initialization routine] Extended information (exinf) [Overrun handler] Target task ID
5	R5	√		[Cyclic/Alarm handler, Initialization routine] Undefined [Overrun handler] Extended information (exinf) for the task
6	R6 to R7	√		Undefined
7	R8 to R14, MACH, MACL, GBR	√	√	Undefined.
8	R15	√	√	R15 points to appropriate stack area.
9	PR	√	√	Undefined
10	[SH3-DSP, SH4AL-DSP] DSR, RS, RE, MOD, A0, A0G, A1, A1G, M0, M1, X0, X1, Y0, Y1	√	√	Undefined

Section4 Application Program Creation

- Notes:
1. These registers can be used. Note that some register contents cannot be guaranteed after service calls. For details, refer to section 3.2.3, Guarantee of Register Contents after Issuing Service Call.
 2. When execution is returned from the entry function (RTS instruction), the contents of these registers must be the same as the value at initiation.
 3. IMASK bits must not be lower than the value at initiation. And IMASK bits must be the same as initial value when execution is returned from the handler.
DSP/CL must be 1 when at least one of CFG_DSP and CFG_CACLOC is checked.
MD = 1, BL = 0, and RB = 0 are required.

Table 4.20 Rules for Using Registers in Time Event Handlers and Initialization Routine (HI7750/4)

No	Registers	Use *1	End Conditions *2	Initial Value
1	PC	√		CPU exception handler start address
2	SR	√	*3	IMASK bits: Same as before exception MD = 1, BL = 0, RB = 0, FD = 0 Other bits: Undefined
3	R0 to R3	√		Undefined
4	R4	√		[Cyclic/Alarm handler, Initialization routine] Extended information (exinf) [Overrun handler] Target task ID
5	R5	√		[Cyclic/Alarm handler, Initialization routine] Undefined [Overrun handler] Extended information (exinf) for the task
6	R6 to R7	√		Undefined
7	R8 to R14, MACH, MACL, GBR	√	√	Undefined.
8	R15	√	√	R15 points to appropriate stack area.
9	PR	√	√	Undefined
9	[SH-4, SH-4A] FPSCR	√		Undefined
10	[SH-4, SH-4A] FPUL	√	√	Undefined
11	[SH-4, SH-4A] FR0_BANK0 to FR15_BANK0	√	√	Undefined
12	[SH-4, SH-4A] FR0_BANK1 to FR15_BANK1	√	√	Undefined

Section4 Application Program Creation

- Notes:
1. These registers can be used. Note that some register contents cannot be guaranteed after service calls. For details, refer to section 3.2.3, Guarantee of Register Contents after Issuing Service Call.
 2. When execution is returned from the entry function (RTS instruction), the contents of these registers must be the same as the value at initiation.
 3. IMASK bits must not be lower than the value at initiation. And IMASK bits must be the same as initial value when execution is returned from the handler.
MD = 1, BL = 0, RB = 0, and FD = 0 are required.

(3) Writing Time Event Handlers and Initialization Routine in C Language Using the DSP

To use the DSP in time event handlers and the initialization routine, refer to section 4.13, Using the DSP in Programs (for HI7000/4 and HI7700/4 only).

(4) Defining Time Event Handlers and Initialization Routine

- a. A cyclic handler can be defined in the following ways:
 - cre_cyc, icre_cyc, acre_cyc, or iacre_cyc service call
 - Defined initially by the configurator
- b. An alarm handler can be defined in the following ways:
 - cre_alm, icre_alm, acre_alm, or iacre_alm service call
 - Defined initially by the configurator
- c. An overrun handler can be defined in the following ways:
 - def_ovr service call
 - Defined initially by the configurator
- d. An initialization routine can be defined in the following ways:
 - Defined initially by the configurator

4.11 CPU Initialization Routines

4.11.1 Creating CPU Initialization Routines in C language

The CPU initialization routine is a program that is first executed after the CPU is reset. For details, refer to section 2.18.1, Resetting the CPU and Initiating the Kernel. Also refer to sample files *nnnn_cpuasm.src* (assembly language) and *nnnn_cpuini.c* (C language).

4.11.2 Defining CPU Initialization Routines in HI7000/4

Define the start address of the CPU initialization routine to the reset vector (address H'0). Also define the initial stack pointer to the reset vector. In addition, start up the kernel at the end of the CPU initialization routine. Create the reset vector in one of the following ways.

- (1) When the user creates a reset vector

Create the reset vector as shown in figure 4.12:

<code>_INIT_SP .EQU H'FFFA000</code>	←Defines the initial stack pointer value after a reset (usually the last address within the internal RAM).
<code>.SECTION C_ResVec, DATA, LOCATE=0</code>	←Specifies C_ResVec as the reset vector section name and allocates the section to address H'0.
<code>.IMPORT _hi_cpuasm</code>	
<code>_ResVec:</code>	
<code>.DATA.L _hi_cpuasm, _INIT_SP</code>	←Specifies the program address for vector number 0 (power-on reset) or vector number 2 (manual reset) as <code>_hi_cpuasm</code> , and the stack pointer as <code>_INIT_SP</code> .
<code>.DATA.L _hi_cpuasm, _INIT_SP</code>	
<code>.END</code>	

Figure 4.12 Example of Creating the Reset Vector (HI7000/4)

(2) When defining the CPU initialization routine by the configurator

Define the CPU initialization routine address and reset stack pointer as an interrupt handler address for interrupt numbers 0 to 3, respectively by the configurator. In addition, allocate the C_hivct section, which is a vector table section created by the configurator, to address H'0 at linkage.

4.11.3 Defining CPU Initialization Routines in HI7700/4 and HI7750/4

Allocate the CPU initialization routine to reset vector address H'a0000000 at linkage.

4.12 System Down Routines

The function specifications of the system down routine are defined as follows. Note that this routine name is fixed.

```
void kernel_sysdwn(W type, ER ercd, VW inf1, VW inf2)
```

Refer to appendix B.2, Information during System Down, for details on the parameters passed to the system down routine. The system down routine must be created and linked to the kernel.

When writing a system down routine in C language, refer to sample file *nnnn_sysdwn.c* for details.

Although the system down routine operates under abnormal conditions, it cannot use kernel functions such as system calls if the kernel fails (error type is negative).

Do not return from a system down routine.

When debugging an application program, maintain the system down routine state and make the program enter an endless loop, and analyze why a system down occurred and takes measures to prevent system downs from occurring.

4.13 Using the DSP in Programs (for HI7000/4 and HI7700/4 only)

4.13.1 Initializing DSR

The initial DSR value depends on the program as shown in table 4.21.

Table 4.21 Initial DSR Value

Program	Initial DSR Value
Task (without attribute TA_COP0)	Undefined
Task (with attribute TA_COP0)	0
Task exception processing routine (without attribute TA_COP0)	Undefined
Task exception processing routine (with attribute TA_COP0)	0
Interrupt handler	Undefined
CPU exception handler	Undefined
Time event handler	Undefined
Initialization routine	Undefined

Initialize DSR to an appropriate value before starting DSP operation. For the initial value, refer to the hardware manual of the target processor.

DSR must be initialized once in each program shown in the above table before DSP operation.

The following shows an example of DSR initialization in a task.

```
#include "kernel.h"
#pragma inline_asm(SetDSR) // Inline assembler function for DSR
setting
static void SetDSR(UW dsr)
{
    lds r4,dsr
}

void task(VP_INT exinf)
{
    SetDSR(0); // Initializes DSR

    // DSP operation
}
```

4.13.2 Using DSP in Handlers

To use the DSP in the following programs, the contents of the DSP registers must be saved and restored in the process shown in figure 4.13. In addition, at compilation, the `code=asmcode` option must be specified by the object format specification option.

- Normal interrupt handlers
- Direct interrupt handlers (HI7000/4)
- CPU exception handlers
- Time event handlers
- Initialization routines
- Timer interrupt routines

When using DSP standby control function in HI7700/4, refer to appendix F.3, Module-Standby State when Initiating Programs.

```

#include "kernel.h"
#include "shdsp.h"           ←Includes header file shdsp.h
#pragma inline_asm(SetDSR)  ←Inline assembler function for DSR
                             setting

static void SetDSR(UW dsr)
{
    lds r4,dsr
}
void HandlerMain(VP_INT exinf) ←Handler main routine
{
    /* Handler processing */
}

void Handler(VP_INT exinf)    ←In the handler start function,
                             writes only the process shown in
                             this figure.
                             Writes the handler main process
                             in HandlerMain().

{
    T_DSP area;              ←Defines the area to save the
                             contents of the DSP registers.

    IniDSP(&area);           ←Saves the contents of the DSP
                             registers.

    SetDSR(0);               ←Initializes DSR.

    HandlerMain(exinf);      ←Calls HandlerMain(), which
                             performs the main process.

    EndDSP(&area);           ←Restores the contents of the
                             DSP registers.
}

```

Figure 4.13 Example of a C Language Handler Using the DSP

Section 5 Configuration

5.1 Read First

Before creating a system, please read and fully understand this section.

The following tools are used for practical configuration:

- The configurator that comes with this product
- HEW

The description in this section is provided on the assumption that the user has already mastered HEW. For information about HEW, refer to the HEW manual or online help. For information about the configurator operation, refer to section 5.4, Configurator, or online help.

5.1.1 Whole Linkage and Separate Linkage

To create load modules for the system, the following operations are necessary:

- Create application files
- Create configuration files using the configurator
- Use the build function of HEW and create load modules

These three operations differ slightly according to the way the load modules are created. Therefore, it is essential to decide on and understand the creation method first.

There are two different approaches to linkage: whole linkage into a single load module, and separate linkage into separate load modules.

Whole Linkage

Whole linkage links the kernel and all configuration files into a single load module (called a whole load module). Application files can be included in a whole load module or in separate load modules (called an application load module).

Figure 5.1 shows the flow for creating a load module using whole linkage.

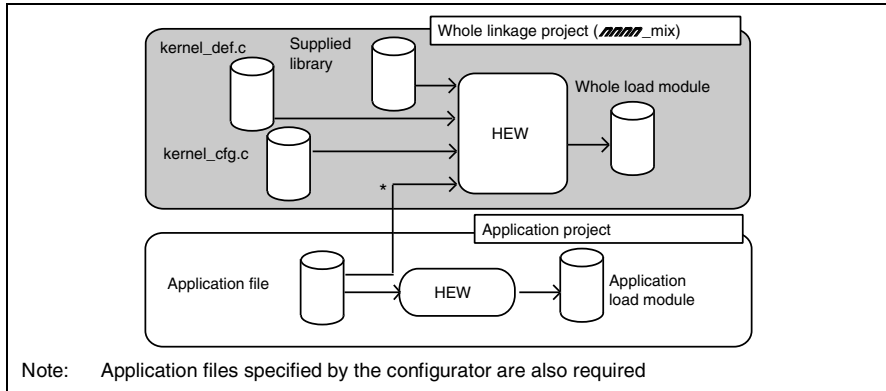

Figure 5.1 Whole Load Module Creation

Separate Linkage

Separate linkage links the kernel code portion and the data portion into separate load modules.

A load module with the kernel code portion, called the kernel load module, is created by linking kernel libraries and kernel_def.c, which is a part of the configurator output file. The linkage unit of a kernel load module is called the kernel side.

A load module with the kernel data portion, called the kernel environment load module, is created by linking kernel_cfg.c, which is a part of the configurator output file. The linkage unit of a kernel environment load module is called the kernel environment side.

Separate linkage makes it possible to change some configuration parameters, such as the maximum number of tasks (CFG_MAXTSKID), and to re-create a kernel environment load module without changing a kernel load module even after the kernel load module is in ROM.

Application files can be included in a kernel load module, a kernel environment load module, or in an independent application load module.

Figure 5.2 shows the flow for creating a load module using separate linkage.

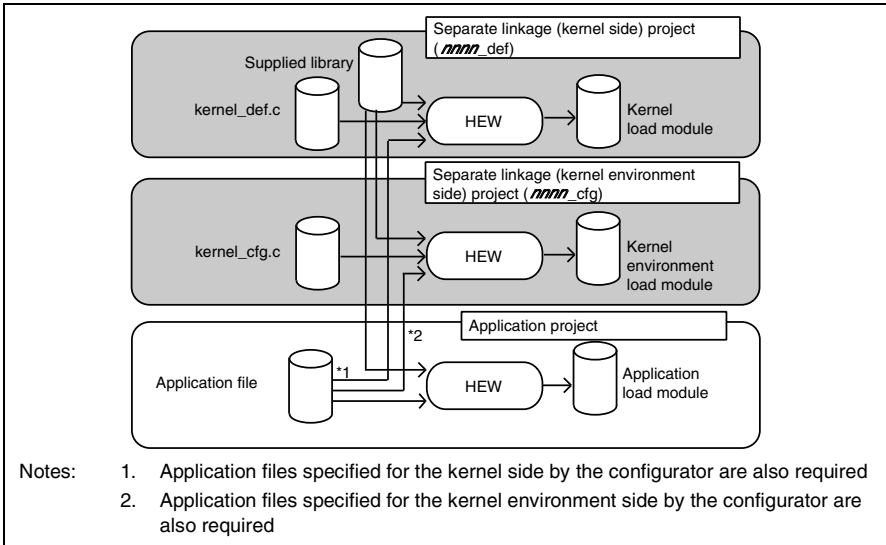

Figure 5.2 Separate Load Module Creation

5.2 Folder Structure

The kernel files are installed in the kernel folder under the installation folder which is specified by the installer program as shown in figure 5.3.

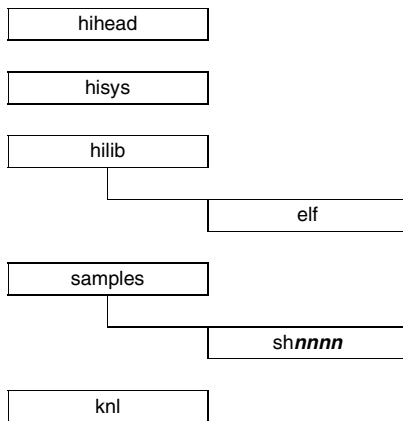

Figure 5.3 Folders under the kernel Folder

5.2.1 hihead Folder

This folder contains header files (e.g. itron.h or kernel.h) which are used in application.

5.2.2 hisys Folder

This folder contains system definition files which are used to compile configuration files.

The files in this folder must not be modified.

5.2.3 hilib Folder

This folder contains the folder which contains kernel library files.

The hilib\elf folder contains ELF-format kernel library files. Refer to the release notes for the compiler version used at library creation.

5.2.4 knl Folder

This folder is provided only under the license with kernel source code.

Refer to the release notes attached to the product for details.

5.2.5 samples\shnnnn Folder

This folder contains sample files for microcomputer corresponding to *nnnn*. This folder also contains the HEW workspace file for load module creation.

Tables 5.1 to 5.3 show relationship between *nnnn* and microcomputer in the HI7000/4 V.2.02, HI7700/4 V.2.02, and HI7750/4 V.2.02, respectively. For the latest information, refer to the release notes attached to the product.

Table 5.1 Relationship between *nnnn* and Microcomputer (HI7000/4 V.2.02)

<i>nnnn</i>	CPU Core	Target Microcomputer	HEW (Compiler Package) Version Used at Creation
7011	SH-2	SH7011, SH7018	1.2 (6.0C)
703x	SH-1	SH7020, SH7021, SH7032, SH7034	1.2 (6.0C)
704x	SH-2	SH7040, SH7041, SH7042, SH7043, SH7044, SH7045, SH7014, SH7016, SH7017	1.2 (6.0C)
7046	SH-2	SH7046, SH7047, SH7048, SH7049, SH7144, SH7145, SH7148	1.2 (6.0C)
7050	SH-2	SH7050, SH7051	1.2 (6.0C)
7052	SH-2	SH7052, SH7053, SH7054	1.2 (6.0C)
7065	SH2-DSP	SH7065	1.2 (6.0C)
7604	SH-2	SH7604	1.2 (6.0C)
7615	SH2-DSP	SH7615, SH7616	1.2 (6.0C)
7618	SH-2	SH7618	4.00.02 (9.00 Release 03)
72060	SH-2A	SH72060	4.00.02 (9.00 Release 03)

Table 5.2 Relationship between *nnnn* and Microcomputer (HI7700/4 V.2.02)

<i>nnnn</i>	CPU Core	Target Microcomputer	HEW (Compiler Package) Version Used at Creation
7707	SH-3	SH7707	1.2 (6.0C)
7708	SH-3	SH7708, SH7708R, SH7708S	1.2 (6.0C)
7709	SH-3	SH7709	1.2 (6.0C)
7709a	SH-3	SH7709A, SH7709S, SH7706	1.2 (6.0C)
7729	SH3-DSP	SH7729, SH7729R, SH7727	1.2 (6.0C)
7290	SH3-DSP	SH7290, SH7294, SH7300	3.0.01 (8.00 Release 00))
7641	SH3-DSP	SH7641	3.0.01 (8.00 Release 00)
7318	SH4AL-DSP (without extended function)	SH7318	3.0.01 (8.00 Release 00)
7343	SH4AL-DSP (with extended function)	SH7343	4.00.02 (9.00 Release 03)

Table 5.3 Relationship between *nnnn* and Microcomputer (HI7750/4 V.2.02)

<i>nnnn</i>	CPU Core	Target Microcomputer	HEW (Compiler Package) Version Used at Creation
7750	SH-4	SH7750, SH7750S, SH7750R	1.2 (6.0C)
7751	SH-4	SH7751, SH7751R	1.2 (6.0C)
7760	SH-4	SH7760	3.0.01 (8.00 Release 00)
7770	SH-4A (without extended function)	SH7770	3.0.01 (8.00 Release 00)
7785	SH-4A (with extended function)	SH7785	4.00.02 (9.00 Release 03)

The contents of the *shnnnn* folder are described below.

(1) HEW3 or Later Versions

The *shnnnn* folder contains the folders shown in figure 5.4.

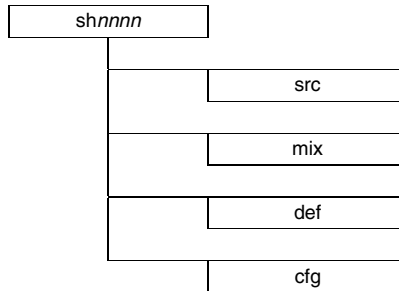

Figure 5.4 Folders under the *shnnnn* Folder (HEW3 or Later Versions)

(a) Sample HEW workspace file (*shnnnn.hws*)

The *shnnnn* folder contains this workspace file. In this workspace, the following three projects are registered.

- (1) For whole linkage (*mix\mix.hwp*)
- (2) For separate linkage, kernel side (*def\def.hwp*)
- (3) For separate linkage, kernel environment side (*cfg\cfg.hwp*)

(b) *shnnnn\src* folder

This folder contains the following source files.

- Sample task (*task.c*)
- Sample timer driver (*nnnn_tmrdrv.c*, *nnnn_tmrdrv.h*, *nnnn_tmrdef.h*)
- Sample CPU initialization routine (*nnnn_cpuasm.src*, *nnnn_cpuini.c*)
- Sample system down routine (*nnnn_sysdwn.c*)
- Sample configurator information file (*nnnn.hcf*), and its generated files (see table 5.4)
- Sample section initialization process (*nnnn_sct.src*, *nnnn_inisct.c*: These files are not used in the state at shipment)
- Only for HI7000/4: Interrupt/CPU exception process (*kernel_exp.src*)
- Only for HI7700/4 and HI7750/4: Interrupt/CPU exception entry process (*nnnn_expent.src*)
- Only for HI7700/4 and HI7750/4: Undefined interrupt/CPU exception process (*nnnn_intdwn.src*)
- *kernel_def.c* and *kernel_cfg.c*
- Only for HI7700/4: DSP standby control function setting file (*kernel_def_dspstby_set.h*)
- Only for HI7700/4: Optimized timer function setting file (*kernel_def_optmr_set.h*)
- Only for SH4AL-DSP and SH-4A in HI7700/4 and HI7750/4: Cache support service call setting file (*kernel_cfg_cac_set.h*)

Section5 Configuration

(c) `shnnnn`\mix folder

This folder contains the mix.hwp file which is the HEW project file for whole linkage.

This folder also contains a folder to store object files to be generated through the mix.hwp project.

(d) `shnnnn`\def folder

This folder contains the def.hwp file which is the HEW project file for separate linkage (kernel side).

This folder also contains a folder to store object files to be generated through the def.hwp project.

(e) `shnnnn`\cfg folder

This folder contains the cfg.hwp file which is the HEW project file for separate linkage (kernel environment side).

This folder also contains a folder to store object files to be generated through the cfg.hwp project.

(2) HEW1.2

The `shnnnn` folder contains the folders shown in figure 5.5.

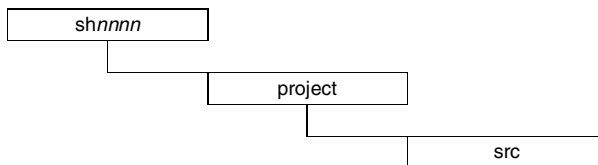

Figure 5.5 Folders under the `shnnnn` Folder (HEW1.2)

(a) Sample HEW workspace file (`shnnnn.hws`)

The `shnnnn` folder contains this workspace file. In this workspace, the following three projects are registered.

- (1) For whole linkage (`project`\mix.hwp)
- (2) For separate linkage, kernel side (`project`\def.hwp)
- (3) For separate linkage, kernel environment side (`project`\cfg.hwp)

(b) `shnnnn`\project folder

This folder contains the three project files that are registered in `shnnnn.hws`. Under this folder, a folder is prepared for each project to store object files to be generated through the respective project.

(c) `shnnnn\project\src` folder

This folder contains the following source files.

- Sample task (task.c)
- Sample timer driver (`nnnn_tmrdrv.c`, `nnnn_tmrdrv.h`, `nnnn_tmrdef.h`)
- Sample CPU initialization routine (`nnnn_cpuasm.src`, `nnnn_cpuini.c`)
- Sample system down routine (`nnnn_sysdwn.c`)
- Sample configurator information file (`nnnn.hcf`), and its generated files (see Table 5.4)
- Sample section initialization process (`nnnn_sct.src`, `nnnn_iniset.c`: These files are not used in the state at shipment)
- Only for HI7000/4: Interrupt/CPU exception process (`kernel_exp.src`)
- Only for HI7700/4 and HI7750/4: Interrupt/CPU exception entry process (`nnnn_expent.src`)
- Only for HI7700/4 and HI7750/4: Undefined interrupt/CPU exception process (`nnnn_intdwn.src`)
- `kernel_def.c` and `kernel_cfg.c`
- Only for HI7700/4: DSP standby control function setting file (`kernel_def_dspstby_set.h`)
- Only for HI7700/4: Optimized timer function setting file (`kernel_def_opttmr_set.h`)

5.3 Operating Procedure

The following describes the normal operating procedure:

1. Double-click `hios\hiuser\shnnnn\nnnn.hcf` and initiate the configurator.
2. Provide necessary settings for the configurator.
3. Save `nnnn.hcf` and generate configuration files. The folder to store generated files must be the folder which includes `kernel_def.c` and `kernel_cfg.c`.
4. Terminate the configurator.
5. Double-click sample HEW workspace file `shnnnn.hws` to initiate HEW. Then, specify the project to be used.
6. Provide necessary operations, such as adding application files to HEW or setting the C compiler or linkage editor options, and execute the build. Then, load module files are created in the respective directories, such as `hios\hiuser\obj`.

5.4 Configurator

This section describes basic configurator operations and settings. For details on configurator operations, refer to the configurator online help.

5.4.1 Overview

The configurator is a tool that is used to set the kernel operating parameters. The configurator creates C source files according to the settings. The created files and applications are built (compiled and linked) into a system (load module).

Figure 5.6 shows the position of the configurator in the system configuration.

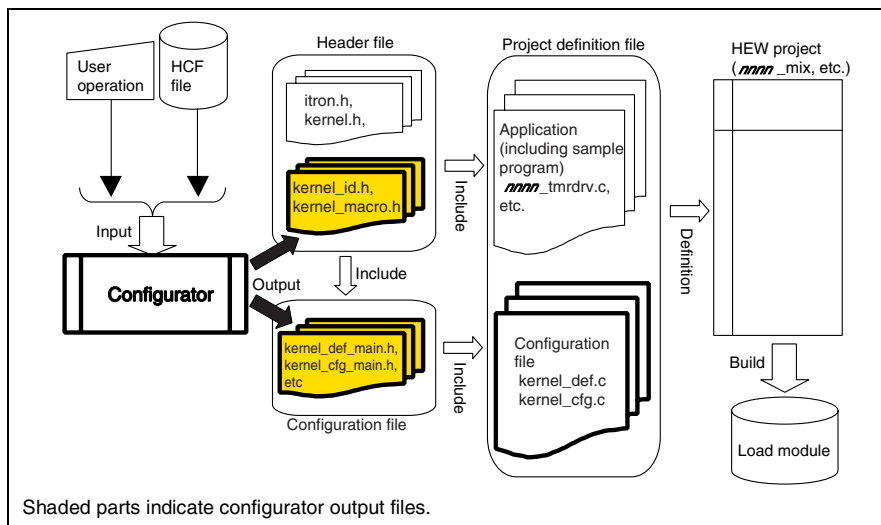

Figure 5.6 Position of Configurator in System Configuration

5.4.2 Configurator Construction

Figure 5.7 shows the configurator window.

The configurator window consists of a list window of configuration information input parts (on the left side) and a configuration information input window (on the right side). Input data in the configuration information input window and execute the Configuration File Creation command with the menu or the tool button. The configuration files are then created.

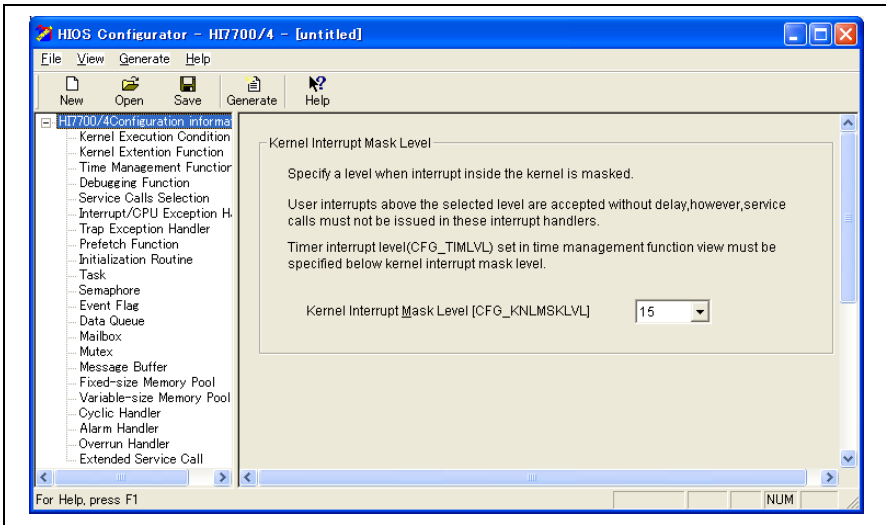

Figure 5.7 Configurator Window

5.4.3 File Operation

(1) Configurator Settings File (HCF File)

Configurator parameters and settings can be saved in the HCF file.

(2) Configuration File Creation

When [Generate Configuration Files] in the [Generate] menu is selected or [Generate] button in the toolbar is pressed, the dialog box shown in figure 5.8 opens. Specify a folder where a configuration file is to be created.

The configuration file must be generated in a folder containing the kernel_def.c or kernel_cfg.c.

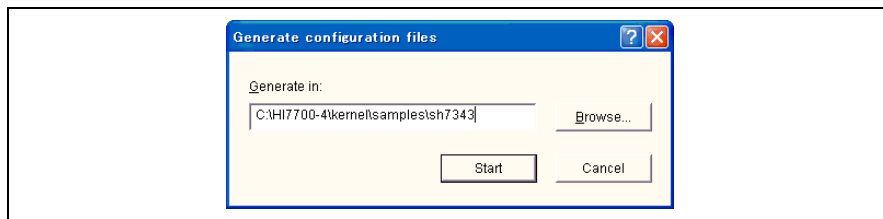

Figure 5.8 Folder Selection Dialog

The files listed in table 5.4 are created in the specified folder. Note that if a file with the same name already exists, the file is automatically overwritten.

5.4.4 Configuration Files

Table 5.4 shows configuration files generated by the configurator.

Table 5.4 Configuration Files

Classification	File Name	Linkage Unit
Header Files	kernel_id.h	Kernel environment side
	kernel_id_sys.h	Kernel side
	kernel_macro.h	Kernel side
System definition	kernel_def_main.h	Kernel side
	kernel_def_inidata.def	Kernel side
	kernel_def_vct.inc	Kernel side (only in HI7000/4)
	kernel_cfg_main.h	Kernel environment side
	kernel_cfg_inidata.def	Kernel environment side

Distinction of linkage unit is related to the following items.

- Automatic assignment of ID number: Refer to (1) kernel_id.h, kernel_id_sys.h.
- Separate linkage: Refer to section 5.4.5, Separate Linkage.

(1) kernel_id.h, kernel_id_sys.h

The objects which are discriminated by the ID numbers can be given ID names at the object creation. The specified ID name is output to ID header files in the following form.

```
#define ID_MainTask 1
```

The ID name in the kernel side is output to kernel_id_sys.h. The ID name in the kernel environment side is output to kernel_id.h.

If the object is created in the kernel environment side (without [Link with Kernel Library] check box), the configurator can assign an ID number automatically. If "Auto" is selected as an ID number in the object creation dialog box, the configurator assigns an ID number automatically.

(2) kernel_macro.h

kernel_macro.h is included from kernel.h. Refer to section 4.1.1, Header File.

(3) System definition files in kernel side (kernel_def_main.h, kernel_def_inidata.def, kernel_def.vct.inc)

kernel_def_main.h and kernel_def_inidata.def are included from kernel_def.c.

kernel_def_vct.inc is generated only in HI7000/4, and is included from *nnnn*_expent.src and *nnnn*_intdwn.src.

(4) System definition files in kernel environment side (kernel_cfg_main.h, kernel_cfg_inidata.def)

kernel_cfg_main.h and kernel_cfg_inidata.def are included from kernel_cfg.c

Note that the contents of the files differ among the HI7000/4 series. If the files are compiled in a different HI7000/4-series environment, an error occurs during compilation. The following error message is output when a file created by the HI7750/4 configurator is compiled in the HI7000/4 or HI7700/4 environment.

```
Unmatch HIOS(This file is designed for HI7750/4.)
```

5.4.5 Separate Linkage

(1) Linkage Unit of Setting Items and Kernel Lock Mode

All setting items are classified into "Kernel side" and "Kernel environment side". The setting items on the kernel side and the setting items on the kernel environment side are separately output to the respective files (refer to table 5.4).

In separate linkage, kernel environment load modules are usually modified alone, without modifying kernel load modules. For this operation, the configurator provides the kernel lock mode. In this mode, editing of the parameters that are to be expanded in a kernel-side output file is limited and no kernel side file is output.

To enter kernel lock mode, put a check mark in [Generate] -> [Kernel Lock Mode].

Whether each item is on the kernel side or kernel environment side can be checked by specifying the kernel lock mode, but for details, refer to the help information of the configurator.

In addition, for generation of objects such as tasks, the kernel side or kernel environment side can be assigned and checked as follows.

- All object creation dialog boxes have the [Link with Kernel Library] check box. If this box is checked, the object is on the kernel side.
- The object that is marked by a flag icon in the object page is on the kernel side.

In an object creation dialog box, when specifying the symbol of applications, such as the address of a task, the symbol instance must be included in the suitable linkage unit (kernel side or kernel environment side).

(2) kernel_id.h

The application on the kernel side must not include kernel_id.h because kernel_id.h is a file on the kernel environment side.

5.4.6 Configurator Settings

Most configurator settings influence kernel operation. These settings are named with the prefix CFG_, and these names are displayed on the configurator screen and also used in this manual. However, note that some settings do not have names.

Table 5.5 lists the settings. The following letters are used in this table:

[L]: Kernel side items. Cannot be changed in the kernel lock mode

[B]: Can be set either for the kernel side or the kernel environment side by [Link with Kernel Library] check box

[BA]: Can be set either for the kernel side or the kernel environment side by [Link with Kernel Library] check box, and an ID name can be specified. If the kernel environment side is selected, "Auto" can be selected for the ID number. When specifying ID names, be careful not to specify the names that have already been used or externally defined names such as function names.

Table 5.5 Configurator Setting Items

1. Kernel Operating Condition Page		
1	kernel interrupt mask level	CFG_KNLMSKLVL [L]
	The kernel has a function to set SR.IMASK to the specified value and execute it. Interrupt handlers with level higher than CFG_KNLMSKLVL cannot issue a service call. For the HI7000/4, interrupts with level higher than CFG_KNLMSKLVL must be described as direct interrupt handlers.	
2	Interrupt nest count with a level higher than the kernel interrupt mask level (only for HI7000/4)	CFG_UPPINTNST
	For the HI7000/4, the maximum nest count for interrupts with level higher than CFG_KNLMSKLVL must be specified.	
3	Interrupt nest count with a level equal to or lower than the kernel interrupt mask level (only for HI7000/4)	CFG_LOWINTNST
	For the HI7000/4, the maximum nest count for interrupts with a level equal to or lower than CFG_KNLMSKLVL must be specified.	
4	How to use TBR register (only for HI7000/4)	CFG_TBR [L]
	Can be chosen from the following. (1) Kernel does not Manage (2) Only for Service Call (3) Task Context When using a microcomputer without TBR, choose (1). For Details, refer to section 4.2.8, TBR Register (SH-2A, SH2A-FPU).	
2. Kernel Extended Function Page		
1	Service call parameter check	CFG_PARCHK [L]
	When this item is checked, the service call static parameter error is checked. Errors that are checked are indicated by the letter [p] in each service call explanation in section 3, Service Calls.	
2	Use of SH3-DSP or SH4AL-DSP (only for HI7700/4)	CFG_DSP [L]
	Remember to check this item when using a processor with the DSP bit (such as SH7729) in the SR. Refer to section 4.2.1 SR Register, and section 4.2.2, Cache Lock Function (SH-3, SH3-DSP).	
3	Use of processor with cache lock function (only for HI7700/4)	CFG_CACLOC [L]
	Refer to section 4.2.2, Cache Lock Function (SH-3, SH3-DSP).	

Table 5.5 Configurator Setting Items (cont)

3. Time Management Function Page			
1	Use of kernel time management function	CFG_TIMUSE	[L]
	When using service calls with time parameters, such as <code>tslp_tsk</code> or the cyclic handler, check <code>CFG_TIMUSE</code> . At this time, remember to create a timer driver. For details, refer to Appendix D, Timer Driver.		
2	Timer interrupt number	CFG_TIMINTNO	[L]
	For HI7000/4, specify the timer interrupt vector number. For HI7700/4 and HI7750/4, specify <code>INTEVT</code> code.		
3	Timer interrupt level	CFG_TIMINTLVL	[L]
	<code>CFG_TIMINTLVL</code> is output as <code>TIM_LVL</code> to <code>kernel_macro.h</code> . The timer interrupt level must be specified with the timer driver according to the information in <code>kernel_macro.h</code> . When using optimized timer driver in HI7700/4, set <code>CFG_TIMINTLVL</code> as the same value as <code>CFG_KNLMSKLVL</code> .		
4	Time event handler stack size	CFG_TIMRSTKSZ	[L]
	Specify a size calculated according to the description in Appendix C.8, Stack Size Used by a Time Event Handler.		
5	Time tick cycle numerator (TIC_NUME) and time tick cycle denominator (TIC_DENO)	CFG_TICNUME, CFG_TICDENO	[L]
	Time tick cycle time is set to <code>TIC_NUME/TIC_DENO</code> [ms]. At least one of <code>TIC_NUME</code> and <code>TIC_DENO</code> must be 1. If a value more than 1 is specified for <code>TIC_DENO</code> , the maximum value specifiable for <code>TMO</code> , <code>RELTIM</code> , or <code>OVRTIM</code> type parameter is limited to [specifiable value with each type]/ <code>TIC_DENO</code> . A value between 1 and 65535 can be specified for <code>TIC_NUME</code> . For <code>TIC_DENO</code> , a value between 1 and 100 can be specified. <code>TIC_NUME</code> and <code>TIC_DENO</code> are output to <code>kernel_macro.h</code> . The time tick cycle must be specified with the timer driver according to the <code>kernel_macro.h</code> information.		
4. Debugging Function Page			
1	Object manipulation functions of debugging extension	CFG_ACTION	[L]
	Check this item when using object manipulation functions ([Action] is displayed in the DX dialog title), such as initiating a task. When <code>CFG_ACTION</code> is checked, please be sure to set up as follows. - Check <code>CFG_TIMUSE</code> in Time Management Function Page. - Select <code>cre_cyc</code> service call in Service Call Selection Page.		
2	Embedding of service call trace function	CFG_TRACE	[L]
	Check this item when using the service call trace function with the debugging extension. Refer to section 2.17.2, Service Call Trace Function.		

Table 5.5 Configurator Setting Items (cont)

3	Type of service call trace function	CFG_TRCTYPE	[L]
Either target trace or emulator trace (tool trace) can be selected. Refer to the manual or on line help of the debugging extension for the environment where emulator trace (tool trace) can be used.			
4	Buffer size for target trace	CFG_TRCBUFZ	
Specify the buffer size in bytes that will be used if target trace is selected.			

5. Service Call Selection Page

Select to embed service calls. If a service call that has not been embedded is issued, the error E_NOSPT is returned.

Note that there is no selectable item of the service call beginning with 'i'. Selecting the service call without 'i' means that the service call beginning with corresponding 'i' has been automatically selected.

When each object is used, be sure to select the service call (see the table below) that generates and defines the object.

Object	Service call	Object	Service call
Task(dynamic stack used)	cre_tsk	Message buffer	cre_mbf
Task(static stack used)	vscr_tsk	Fixed-size memory pool	cre_mpf
Task exception processing routine	def_tex	Variable-size memory pool	cre_mpl
Semaphore	cre_sem	Cyclic handler	cre_cyc
Eventflag	cre_flg	Alarm handler	cre_alm
Data queue	cre_dtq	Overrun handler	def_ovr
		Extended service call	def_svc

In addition, with the service call selection page, vchg_cop service call of the HI7700/4 cannot be chosen but is automatically incorporated by incorporating DSP standby control function. For details, refer to Appendix F, DSP Standby Control (HI7700/4).

6. Interrupt Handler/CPU Exception Handler Page

1	Maximum interrupt number	CFG_MAXVCTNO	[L]
Specify the maximum number of interrupts or exception factors used in the system. For HI7000/4, specify the processor vector number. For HI7700/4 and HI7750/4, specify the processor interrupt or exception code. The maximum allowed value is 511 for HI7000/4, and 0x3fe0 for HI7700/4 and HI7750/4.			
2	Interrupt handler stack size	CFG_IRQSTKSZ	
For details on stack size calculations, refer to Appendix C.7, Interrupt Handler Stacks.			
3	Only the direct interrupt handler is used (only for HI7000/4)	CFG_DIRECT	[L]
When neither the normal interrupt handler, CPU exception handler, nor trap exception handler is used, this must be checked.			

Table 5.5 Configurator Setting Items (cont)

4	Handler definition information is assigned to RAM, and def_inh, def_exc, and vdef_trp are embedded	CFG_VCTRAM	[L]
	Specifies whether the definition information for the interrupt handler, CPU exception handler, and trap exception handler is assigned to ROM or RAM. If it is assigned to ROM, the amount of ROM consumption can be smaller, def_inh, def_exc, vdef_trp cannot be used, and check for linking with the kernel cannot be cleared when the handler is defined by the configurator.		
5	Register Bank (only for HI7000/4)	CFG_REGBANK	[L]
	When using the register banks in SH-2A, check this. When using a microcomputer without register banks (microcomputers other than SH-2A), do not check this. For Details, refer to section 4.2.9, Register Banks (SH-2A, SH2A-FPU).		
6	IBNR Register Address (only for HI7000/4)	CFG_IBNR_ADR	[L]
	Specify the IBNR register address. For Details, refer to section 4.2.9, Register Banks (SH-2A, SH2A-FPU).		
7	Definition of interrupt handler or CPU exception handler	—	[B]
	Specifiable contents are the same as those of the def_inh and def_exc service calls. They are also the same as those of the vdef_trp service call for HI7000/4. When defining this item on the kernel environment side, the def_inh or def_exc service call must be embedded for HI7700/4 or HI7750/4. For the HI7000/4, whether or not the def_inh and vdef_trp service calls are embedded is automatically determined. These service calls cannot be selected in the service call selection page.		
7. Trap Exception Handler Page (only for HI7700/4, HI7750/4)			
1	Maximum trap number	CFG_MAXTRPNO	[L]
	Specify the maximum trap number to be used in the system. The maximum number specifiable is 255.		
2	CPU exception handler definition (for TRAPA)	—	[B]
	Specifiable contents are the same as those of the vdef_trp service call. When defining this item on the kernel environment side, the vdef_trp service call must be embedded.		
8. Pre-fetch Function Page (only for HI7700/4 and HI7750/4)			
1	Address and range to be pre-fetched	—	[B]
	Specify the start address and size to be pre-fetched when the kernel is in the idle state.		
9. Initialization Routine Page			
1	Initialization routine definition	—	[B]
	Specify the initialization routine settings, such as the initialization routine address, extended information, and stack size.		

Table 5.5 Configurator Setting Items (cont)

10. Task Page		
1	Maximum task ID	CFG_MAXTSKID
	Maximum task ID using a static stack	CFG_STSTKID [L]
	<p>Tasks with ID numbers between 1 and CFG_STSTKID use the static stack, and tasks with ID numbers between CFG_STSTKID + 1 and CFG_MAXTSKID use the dynamic stack.</p> <p>The maximum value specifiable for CFG_MAXTSKID is 1023, and that for CFG_STSTKID is CFG_MAXTSKID.</p> <p>The following service calls must be embedded, corresponding to the CFG_MAXTSKID and CFG_STSTKID settings:</p> <ul style="list-style-type: none"> • When CFG_STSTKID = 0, all tasks are set to use the dynamic stack. The cre_tsk service call must be embedded. • When CFG_MAXTSKID = CFG_STSTKID, all tasks are set to use the static stack. The vschr_tsk service call must be embedded. • When CFG_MAXTSKID > CFG_STSTKID, the cre_tsk and vschr_tsk service calls must be embedded. 	
2	Definition of static stack	— [L]
	<p>If a value other than 0 is specified for CFG_STSTKID, define the static stack area used by tasks with ID between 1 and CFG_STSTKID.</p>	
3	Maximum task priority (TMAX_TPR1)	CFG_MAXTSKPRI [L]
	<p>The range of usable task priorities is 1 to CFG_MAXTSKPRI. The maximum value specifiable is 255. The same value of CFG_MAXTSKPRI is output to kernel_macro.h as TMAX_TPRI.</p>	
4	Dynamic stack area size	CFG_TSKSTKSZ
	<p>When a task with ID between CFG_STSTKID + 1 and CFG_MAXTSKID is created, a stack area is allocated within the specified area.</p>	
5	Task creation	— [BA]
	<p>Setting contents are the same as those of the cre_tsk and vschr_tsk service calls.</p> <p>When creating a task using the static stack, select a stack used by the task in the static stack defined in item 2. Tasks with the same stack specification share the stack.</p> <p>When specifying [Start Task after Creating It (TA_ACT)] for attribute, the order of task execution may change according to the order of task creation. Tasks are first created from the top of the kernel window side, then from the top of the kernel environment window side. Move the task registration location by pressing [Up] or [Down] in the pop up menu.</p> <p>Automatic ID assignment can be set only to tasks using the dynamic stack and that have been created on the kernel environment side.</p>	
6	Definition of task exception processing routine	— [B]
	<p>The task exception processing routine can be defined for a task created in item 5, if necessary. For separate linkage, the task and the task exception processing routine must include the same linkage unit (kernel side or kernel environment side) as the target task.</p> <p>When the task exception processing routine is defined, the def_tex service call must be embedded.</p>	

Table 5.5 Configurator Setting Items (cont)

11. Semaphore Page			
1	Maximum semaphore ID	CFG_MAXSEMID	
	The range of usable semaphore IDs is 1 to CFG_MAXSEMID. The maximum value specifiable is 1023. When no semaphore is used, specify 0. When a value more than 1 is specified, the cre_sem service call must be embedded.		
2	Semaphore creation	—	[BA]
	Specifiable contents are the same as those of the cre_sem service call.		
12. Event Flag Page			
1	Maximum event flag ID	CFG_MAXFLGID	
	The range of usable event flag IDs is 1 to CFG_MAXFLGID. The maximum value specifiable is 1023. When no event flag is used, specify 0. When a value more than 1 is specified, the cre_flg service call must be embedded.		
2	Event flag creation	—	[BA]
	Specifiable contents are the same as those of the cre_flg service call.		
13. Data Queue Page			
1	Maximum data queue ID	CFG_MAXDTQID	
	The range of usable data queue IDs is 1 to CFG_MAXDTQID. The maximum value specifiable is 1023. When no data queue is used, specify 0. When a value more than 1 is specified, the cre_dtq service call must be embedded.		
2	Data queue area size	CFG_DTQSZ	
	When a data queue is created, a data queue is allocated within an area of the specified size.		
3	Data queue creation	—	[BA]
	Specifiable contents are the same as those of the cre_dtq service call.		
14. Mailbox Page			
1	Maximum mailbox ID	CFG_MAXMBXID	
	The range of usable mailbox IDs is 1 to CFG_MAXMBXID. The maximum value specifiable is 1023. When no mailbox is used, specify 0. When a value more than 1 is specified, the cre_mbx service call must be embedded.		
2	Maximum message priority (TMAX_MPRI)	CFG_MAXMSGPRI	[L]
	The range of usable message priorities is 1 to CFG_MAXMSGPRI. The same value of CFG_MAXMSGPRI is output to kernel_macro.h as TMAX_MPRI.		
3	Mailbox creation	—	[BA]
	Specifiable contents are the same as those of the cre_mbx service call.		

Table 5.5 Configurator Setting Items (cont)

15. Mutex Page			
1	Maximum mutex ID	CFG_MAXMTXID	
	The range of usable mutex IDs is 1 to CFG_MAXMTXID. The maximum value specifiable is 1023. When no mutex is used, specify 0. When a value more than 1 is specified, the cre_mtx service call must be embedded.		
2	Mutex creation	—	[BA]
	Specifiable contents are the same as those of the cre_mtx service call.		
16. Message Buffer Page			
1	Maximum message buffer ID	CFG_MAXMBFID	
	The range of usable message buffer IDs is 1 to CFG_MAXMBFID. The maximum value specifiable is 1023. When no message buffer is used, specify 0. When a value more than 1 is specified, the cre_mbf service call must be embedded.		
2	Message buffer area size	CFG_MBFSZ	
	When a message buffer is created, a message buffer is allocated with area of the specified size.		
3	Message buffer creation	—	[BA]
	Specifiable contents are the same as those of the cre_mbf service call.		
17. Fixed-Size Memory Pool Page			
1	Maximum fixed-size memory pool ID	CFG_MAXMPFID	
	The range of usable fixed-size memory pool IDs is 1 to CFG_MAXMPFID. The maximum value specifiable is 1023. When no fixed-size memory pool is used, specify 0. When a value more than 1 is specified, the cre_mpf service call must be embedded.		
2	Fixed-size memory pool area size	CFG_MPFSZ	
	When a fixed-size memory pool is created, a fixed-size memory pool is allocated with area of the specified size.		
3	Fixed-size Memory Pool Management Method	CFG_MPFMANAGE	[L]
	When this is checked, kernel management tables are not located in a memory pool domain. Refer to section 2.14, Fixed-Size Memory Pool.		
4	Fixed-size memory pool creation	—	[BA]
	Specifiable contents are the same as those of the cre_mpf service call.		
18. Variable-Size Memory Pool Page			
1	Maximum variable-size memory pool ID	CFG_MAXMPLID	
	The range of usable variable-size memory pool IDs is 1 to CFG_MAXMPLID. The maximum value specifiable is 1023. When no variable-size memory pool is used, specify 0. When a value more than 1 is specified, the cre_mpl service call must be embedded.		

Table 5.5 Configurator Setting Items (cont)

2	Variable-size memory pool area size	CFG_MPLSZ	
	When a variable-size memory pool is created, a variable-size memory pool is allocated with area of the specified size.		
3	Variable-size memory pool management method	CFG_NEWMPL	[L]
	When CFG_NEWMPL is not selected, the conventional management method in the previous versions (HI7000/4 V.2.00 Release 02 or earlier, HI7700/4 V.1.03 Release 02 or earlier, and HI7750/4 V.1.1.00 or earlier versions) is applied.		
	Selecting CFG_NEWMPL improves the following.		
	1. Acquisition and return of memory blocks are faster when a large number of memory blocks are used in the memory pool.		
	2. The VTA_UNFRAGMENT attribute can be used to reduce fragmentation of free space.		
	When CFG_NEWMPL is selected, note that new members are added to the T_CMPL structure in comparison with the conventional method. For details, refer to section 3.14.1, Create Variable-Size Memory Pool.		
4	Variable-size memory pool creation	—	[BA]
	Specifiable contents are the same as those of the cre_mpl service call.		
19. Cyclic Handler Page			
1	Maximum cyclic handler ID	CFG_MAXCYCID	
	The range of usable cyclic handler IDs is 1 to CFG_MAXCYCID. The maximum value specifiable is 14. When no cyclic handler is used, specify 0.		
	When a value more than 1 is specified, the cre_cyc service call must be embedded.		
2	Cyclic handler creation	—	[BA]
	Specifiable contents are the same as those of the cre_cyc service call.		
20. Alarm Handler Page			
1	Maximum alarm handler ID	CFG_MAXALMID	
	The range of usable alarm handler IDs is 1 to CFG_MAXALMID. The maximum value specifiable is 15. When no alarm handler is used, specify 0.		
	When a value more than 1 is specified, the cre_alm service call must be embedded.		
2	Alarm handler creation	—	[BA]
	Specifiable contents are the same as those of the cre_alm service call. Refer to the service call description in section 3.		
21. Overrun Handler Page			
1	Overrun handler definition	—	[B]
	Specifiable contents are the same as those of the def_ovr service call. When defining this item, the def_ovr service call must be embedded.		

Table 5.5 Configurator Setting Items (cont)

22. Extended Service Call Page		
1	Maximum function code of extended service call	CFG_MAXSVCCD
	The range of usable function codes is 1 to CFG_MAXSVCCD. The maximum value specifiable is 1023. When no extended service call is used, specify 0. When a value more than 1 is specified, the def_svc service call must be embedded.	
2	Extended service call creation	— [B]
	Specifiable contents are the same as those of the def_svc service call.	

5.5 When Optimized Timer Driver is Used (HI7700/4)

Refer to Appendix E, Optimized Timer Driver (HI7700/4).

5.6 When DSP Standby Control Function is Used (HI7700/4)

Refer to Appendix F, DSP Standby Control.

5.7 When Cache Support Function is Used on SH4AL-DSP (HI7700/4) or SH-4A (HI7750/4)

In kernel_cfg_cac_set.h, define the size of the instruction cache and operand cache built in the target microcomputer. When the on-chip cache has a 2-way structure, specify the actual cache size $\times 2$. When the on-chip cache has a 4-way structure and it is used in 2-way mode, the size must not be doubled. kernel_cfg_cac_set.h is included by kernel_cfg.c. An example is shown below.

```

/*****
* Cache size information
* Please define the specified Cache size in CPU to be used.
* (1) IC_SIZE : Instruction Cache size [Bytes]
* (2) OC_SIZE : Operand Cache size [Bytes]
*****/
#define IC_SIZE 32768UL
#define OC_SIZE 32768UL

```

Note that kernel_cfg_cac_set.h is stored only in the sample folders for the microcomputers that include SH4AL-DSP or SH-4A CPU core (the sh7318 and sh7343 folders in HI7700/4 V.2.02 Release 00 and the sh7770 and sh7785 folders in HI7750/4 V.2.02 Release 00 as of writing this manual). At this manual creation time, they are sh7318 and sh7343 folders of the HI7700/4 and sh7770 and sh7785 folders of the HI7750/4. Similarly, kernel_cfg.c only in these folders includes kernel_cfg_cac_set.h.

5.8 HEW Workspace and Projects

Use the following procedure to create load modules with the HEW build function.

1. Add the files necessary for creating the load module in a project.
2. Specify the options for the compiler, assembler, and optimized linkage editor.
3. Run the Build command.

This product supplies a sample workspace file (*shnnnn.hws*). Double-clicking this file opens it and starts HEW.

The *shnnnn.hws* includes the following sample projects for the target microcomputer.

(1) HEW3 or later

- mix: Whole linkage
- def: Separate linkage, kernel side
- cfg: Separate linkage, kernel environment side

(2) HEW1.2

- *nnnn*_mix: Whole linkage (for the microcomputer corresponding to *nnnn*)
- *nnnn*_def: Separate linkage, kernel side (for the microcomputer corresponding to *nnnn*)
- *nnnn*_cfg: Separate linkage, kernel environment side (for the microcomputer corresponding to *nnnn*)

Select a project for the appropriate microcomputer, and change the settings as explained below. The following explains only the items that should be especially kept in mind.

To select a sample project, select a project from the workspace window and select [Set as Current Project] from the pop-up menu as shown in figure 5.9.

Opening a project file and clicking the Build button compiles, assembles, links, and converts the files in the project, and creates a load module.

In addition, the HEW screen carried after this section was acquired in the following environments.

- HEW: HEW4 which is attached in compiler package V.9.00 Release 03
- Kernel: HI7700/4 V.2.02 Release 00

By the HEW version or kernel, HEW screen may differ from a screen found in this section.

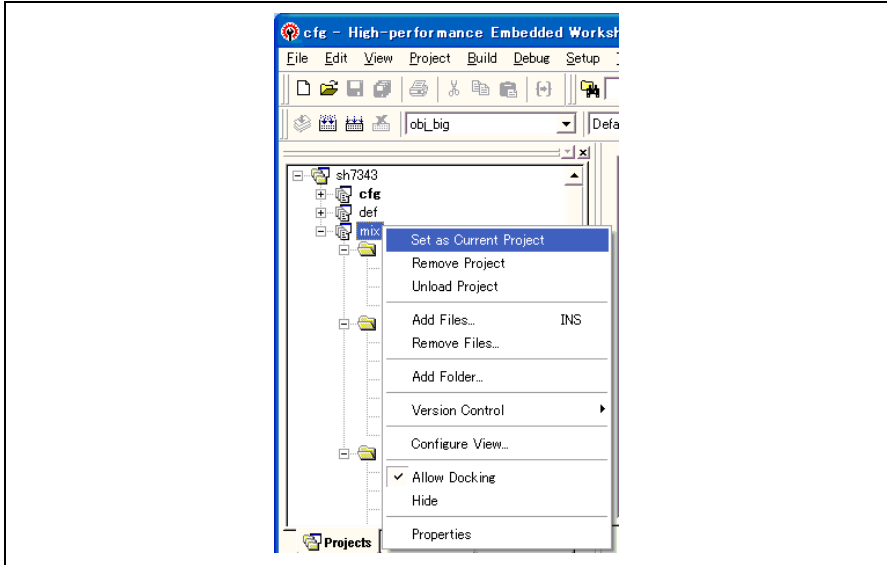

Figure 5.9 Project Selection

5.9 Kernel Libraries

The kernel library is stored in the hilib\elf folder and linked in the kernel side at the separate linkage (def) or whole linkage (mix). Multiple kernel libraries should be specified with the priority according to the function to be used. In the HEW, when the kernel library is specified upper of the screen for specifying the library, the priority becomes higher (see figure 5.11).

5.9.1 HI7000/4

Table 5.6 lists the linkage priority of the HI7000/4 kernel library.

Table 5.6 Linkage Priority of the Kernel Library (HI7000/4)

CPU Core	Linkage Priority
SH-1, SH-2, SH-2A (without FPU)	For big endian: hiknl.lib For little endian: hiknl_little.lib
SH2-DSP	(1) dsp_knl.lib (2) hiknl.lib
SH2A-FPU	(1) fpu_knl.lib (2) hiknl.lib

Following kernel libraries are used for supporting the debugger and usually not used.

- hiexpand.lib and hiexpand_little.lib
- dsp_expand.lib
- fpu_expand.lib

5.9.2 HI7700/4

Table 5.7 lists the linkage priority of the HI7700/4 kernel library.

Table 5.7 Linkage Priority of the Kernel Library (HI7700/4)

CPU Core	DSP-Standby Control Function	Optimized timer Driver Function	Linkage Priority	
SH-3	(Cannot be used)	Unused	(1) 7708_cache_???.lib (2) hiknl_???.lib	
		Used	(1) opttmr_???.lib (2) 7708_cache_???.lib (3) hiknl_???.lib	
SH3-DSP	Unused	Unused	(1) dsp_knl_???.lib (2) 7708_cache_???.lib (3) hiknl_???.lib	
		Used	(1) dsp_knl_???.lib (2) opttmr_???.lib (3) 7708_cache_???.lib (4) hiknl_???.lib	
	Used	Unused	(1) dspstby_???.lib (2) dsp_knl_???.lib (3) 7708_cache_???.lib (4) hiknl_???.lib	
		Used	(1) dspstby_???.lib (2) dsp_knl_???.lib (3) opttmr_???.lib (4) 7708_cache_???.lib (5) hiknl_???.lib	
	SH4AL-DSP (without extended function)	Unused	Unused	(1) sh4al_dsp_knl_???.lib (2) sh4al_cache_???.lib (3) hiknl_???.lib
			Used	(1) sh4al_dsp_knl_???.lib (2) sh4al_opttmr_???.lib (3) sh4al_cache_???.lib (4) hiknl_???.lib
Used	Unused	Unused	(1) sh4al_dspstby_???.lib (2) sh4al_dsp_knl_???.lib (3) sh4al_cache_???.lib (4) hiknl_???.lib	
		Used	(1) sh4al_dspstby_???.lib (2) sh4al_dsp_knl_???.lib (3) sh4al_opttmr_???.lib (4) sh4al_cache_???.lib (5) hiknl_???.lib	

Table 5.7 Linkage Priority of the Kernel Library (HI7700/4) (cont.)

CPU Core	DSP-Standby Control Function	Optimized timer Driver Function	Linkage Priority
SH4AL- DSP (with extended function)	Unused	Unused	(1) sh4al_dsp_knl_???.lib (2) shx2_cache_???.lib (3) hiknl_???.lib
		Used	(1) sh4al_dsp_knl_???.lib (2) sh4al_opttmr_???.lib (3) shx2_cache_???.lib (4) hiknl_???.lib
	Used	Unused	(1) sh4al_dspstby_???.lib (2) sh4al_dsp_knl_???.lib (3) shx2_cache_???.lib (4) hiknl_???.lib
		Used	(1) sh4al_dspstby_???.lib (2) sh4al_dsp_knl_???.lib (3) sh4al_opttmr_???.lib (4) shx2_cache_???.lib (5) hiknl_???.lib

The following kernel libraries are used to support the debugger and usually not used.

- hiexpand_???.lib
- dsp_expand_???.lib
- sh4al_dsp_expand_???.lib

Note: The 7708_cache_???.lib library is not dedicated for the SH7708; it is used for all SH-3 and SH3-DSP series.

5.9.3 HI7750/4

Table 5.8 lists the linkage priority of the HI7750/4 kernel library.

Table 5.8 Linkage Priority of the Kernel Library (HI7750/4)

CPU Core	Linkage Priority
SH-4	(1) 7750_cache_???.lib (2) hiknl_???.lib
SH-4A (without extended function)	(1) sh4a_cache_???.lib (2) hiknl_???.lib
SH-4A (with extended function)	(1) shx2_cache_???.lib (2) hiknl_???.lib

The following kernel library is used to support the debugger and usually not used.

- hiexpand_???.lib

Note: The 7750_cache_???.lib library is not dedicated for the SH7750; it is used for all SH-4 series.

5.10 Section Configuration

The allocation address of each module is determined at the time of linkage regardless of the linkage methods. A module is allocated in section units.

The sections are described here.

Table 5.9 lists the section names for the supplied files included with the product.

The first letter in a section name gives the section attribute.

P Attribute: Program sections, which can be located in a ROM.

C Attribute: Constant sections, which can be located in a ROM.

B Attribute: Non-initialized data sections, which must be located in a RAM.

D and R Attribute: D attribute is an initialized data section, which can be located in a ROM. When locating a D-attribute section in a ROM, the contents of the section must be copied to a RAM before executing the program so as to enable the contents to be treated as variables. To be specific, the following procedures are required:

- Create an R-attribute section with the same size as the D-attribute section by using the ROM support function provided by the optimized linkage editor. Allocate the R-attribute section to a RAM.
- Create a program for copying the contents of the D-attribute section to the R-attribute section and execute it at program initiation (usually a CPU initialization subroutine).

Table 5.9 Section Names

Section Name	File Name	Description	Allocation to Non-Cacheable Area
P_hiknl	Kernel library *1	Kernel program	Not necessary
P_hireset		Kernel initialization process	Not necessary
P_hiknl_P2 *4		Part of cache operation	Necessary
P_hiexpent	<i>nnnn_expent.src</i> *2 <i>kernel_exp.src</i> *3	Kernel interrupt or exception entry/exit processing routine	Not necessary
P_hiintdwn	<i>nnnn_intdwn.src</i> *2 <i>kernel_exp.src</i> *3	Undefined kernel interrupt/exception analysis process	Not necessary
C_hidef	<i>kernel_def.c</i>	Definition information on the kernel side	Not necessary
C_hivct		CPU vector table , Interrupt handler or CPU exception handler definition information	Not necessary *7
C_hitrp *2		CPU exception handler definition information for TRAPA	Not necessary
C_hibase		Service call interface information	Not necessary
B_hidef *5		Kernel work area	Not necessary
C_hisysmt	<i>kernel_cfg.c</i>	Configuration information on the kernel environment side	Not necessary
C_hicfg		Configuration information other than C_hisysmt on the kernel environment side	Not necessary
B_hivct *6		CPU vector table	Not necessary
B_hiwrk		Kernel work area	Not necessary
B_hicfg *5		Kernel work area	Not necessary
B_himpl		Variable-/fixed-size memory pool area	Not necessary
B_hidystk		Dynamic stack	Not necessary
B_histstk		Static stack	Not necessary
B_hiirqstk		Interrupt handler and time event handler stack	Not necessary
B_hitrceml		DX emulator trace (tool trace) area	Not necessary
B_hitrcbuf		DX target trace buffer	Not necessary
P_hisysdwn	<i>nnnn_sysdwn.c</i>	Sample system down routine	Not necessary
P_hicpuasm	<i>nnnn_cpuasm.src</i>	Sample CPU initialization routine	*8
P_hicpuini	<i>nnnn_cpuini.c</i>	Sample CPU initialization subroutine	Not necessary
P_hitmrdv	<i>nnnn_tmrdrv.c</i>	Sample timer driver	Not necessary
Determined by the user	Applications	---	

Notes: *1 See section 5.9, Kernel Libraries.

*2 Only in the HI7700/4 and HI7750/4

*3 Only in the HI7000/4

*4 Only for *sh4al_cache_???.lib* and *shx2_cache_???.lib* in the HI7700/4 and *sh4a_cache_???.lib* and *shx2_cache_???.lib* in the HI7750/4.

*5 When the fixed-size memory pool is created while CFG_MPFMANAGE is selected through the configurator or when the variable-size memory pool with the VTA_UNFRAGMENT is created while CFG_NEWMPL is selected.

*6 Only when CFG_VCTRAM is selected and the OS is the HI7000/4

- *7 Allocate the section to address 0 when the reset vector is specified through the configurator in the HI7000/4. Also refer to section 4.11.2, Defining CPU Initialization Routines in HI7000/4.
- *8 Allocate the area to the CPU reset vector address (H'a0000000 in the P2 area) in the HI7700/4 and HI7750/4.

5.11 Settings Common to All Projects

5.11.1 CPU Options for the Compiler and Assembler

The cpu option for the compiler and the assembler depends on the microcomputer in use. In particular, the correct CPU option must be specified for compilation of the files indicated in table 5.10 below.

Table 5.10 CPU Options

Kernel	CPU in Use	Target Source File	CPU Option
HI7000/4	SH-2A, SH2A-FPU	1. kernel_def.c (this file is included in mix and def projects) 2. kernel_cfg.c (this file is included in mix and cfg projects) 3. kernel_exp.src 4. All files that use service calls when "Only for service call" is chosen as CFG_TBR.	SH2A or SH2AFPU
HI7700/4	SH4AL-DSP	1. kernel_def.c (this file is included in mix and def projects)	SH4ALDSP
HI7750/4	SH-4A	2. kernel_cfg.c (this file is included in mix and cfg projects) 3. The source file which uses a cache support service call	SH4A

5.11.2 GBR Option of Compiler (Compiler Package V.7.1 or Later)

The GBR intrinsic function of compiler is used in the sample timer driver for some devices. Specify "gbr=user", when you use these sample timer drivers. The sample timer drivers which use the GBR intrinsic function in each kernel version at this manual creation time are shown below.

- HI7000/4 V.2.02: All sample timer drivers other than SH72060 and SH7618
- HI7700/4 V.2.02: All sample timer drivers other than SH7290, SH7318, SH7641, and SH7343
- HI7700/4 V.2.02: All sample timer drivers other than SH7760, SH7770, and SH7785

5.11.3 PACK Option and #pragma pack of Compiler (Compiler Package V.8 or Later)

The structure parameters to be passed to the kernel must be aligned with the same boundary alignment value as that for the members. To achieve this, #pragma pack 4 is specified in the definition of the structure type in the standard header files (itron.h and kernel.h)

5.11.4 Include Directory for Compiler and Assembler

As the standard header files are stored in the hihead folder, specify the hihead folder as the include directory for usual operation.

For kernel_def.c and kernel_cfg.c, specify the hisys folder as the include directory.

5.11.5 When SH2A-FPU or SH-4 or SH-4A is Used

Appendix G, Notes on FPU of SH2A-FPU, SH-4, SH4A also has the description about a compiler option. When you do not use an FPU function, please be sure to refer this.

5.11.6 TBR Option of Compiler (Compiler Package V.9 or Later)

The TBR option is only for SH-2A and SH2A-FPU.

When "Only for service call" is chosen as CFG_TBR, the kernel initializes the TBR register. The application must not modify TBR. For this reason, the TBR option and #pragma tbr must not be used.

5.12 Build for Whole Linkage (mix)

5.12.1 Adding Files to a Project

Table 5.11 lists the source program sample files to be added to the project. The sample project file already contains the files shown in this table.

Table 5.11 Source Program Files Added to Project (mix)

File Name	Description	Notes
kernel_def.c * ¹	Kernel side configuration file	Mandatory
kernel_cfg.c * ¹	Kernel environment side configuration file	Mandatory
<i>nnnn</i> _sysdwn.c * ¹	System down routine	Mandatory
<i>nnnn</i> _expent.src * ¹ * ²	Interrupt or exception entry/exit processing routine	Mandatory
<i>nnnn</i> _intdwn.src * ¹ * ²	Undefined interrupt detailed information acquisition process	Mandatory
kernel_exp_src.c * ¹ * ³	Interrupt or exception processing routine	Mandatory
<i>nnnn</i> _cpuasm.src * ¹ , <i>nnnn</i> _cpuini.c * ¹	CPU initialization routine	Mandatory for executing by reset
<i>nnnn</i> _tmrdv.c * ¹	Standard timer driver	When using optimized timer driver in HI7700/4, do not include this
task.c * ¹	Sample task	
Application files	—	

- Notes: 1. These files are in the sh*nnnn*\src or sh*nnnn*\project\src folder.
 2. Only in the HI7700/4 and HI7750/4
 3. Only in the HI7000/4

5.12.2 Defining Endian

In the supplied sample project for the microcomputers that support little endian, the endian should be selected in the HEW build configuration. Select the build configuration as shown in figure 5.10.

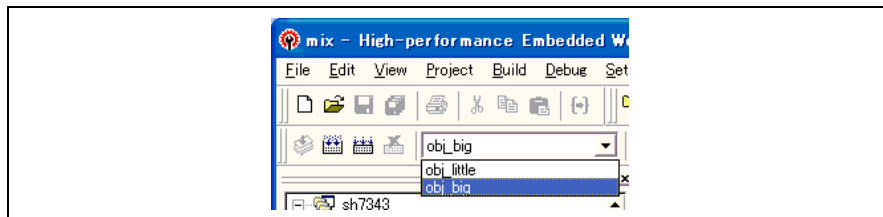

Figure 5.10 Selection of Endian

5.12.3 Setting Optimized Linkage Editor Options

- (1) [Input] Category, [Library files]

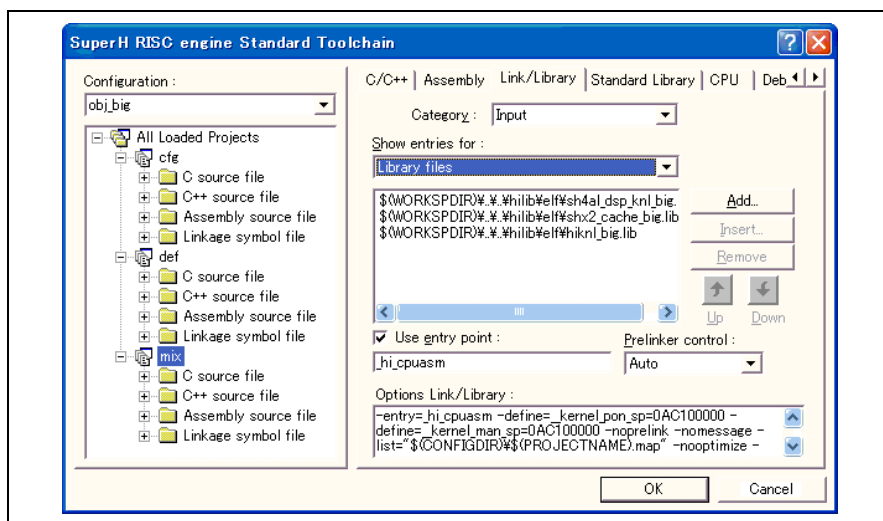

Figure 5.11 Optimized Linkage Editor [Input] Category, [Library files]

Be sure to specify necessary libraries as described in 5.9, Kernel Libraries. Also, specify application libraries as required.

(2) [Input] Category, [Defines]

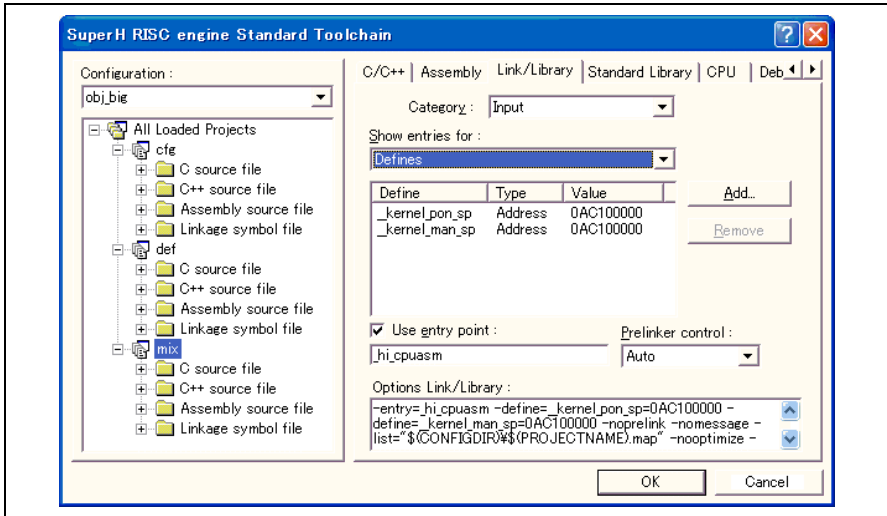

Figure 5.12 Optimized Linkage Editor [Input] Category, [Defines]

In the sample file (*mmn_cpasm.src*) for the HI7700/4 and the HI7750/4, the following symbols are externally referred to, so define them here.

- `__kernel_pon_sp`: Initial stack pointer used for power-on reset
- `__kernel_man_sp`: Initial stack pointer used for manual reset

(3) [Section] Category

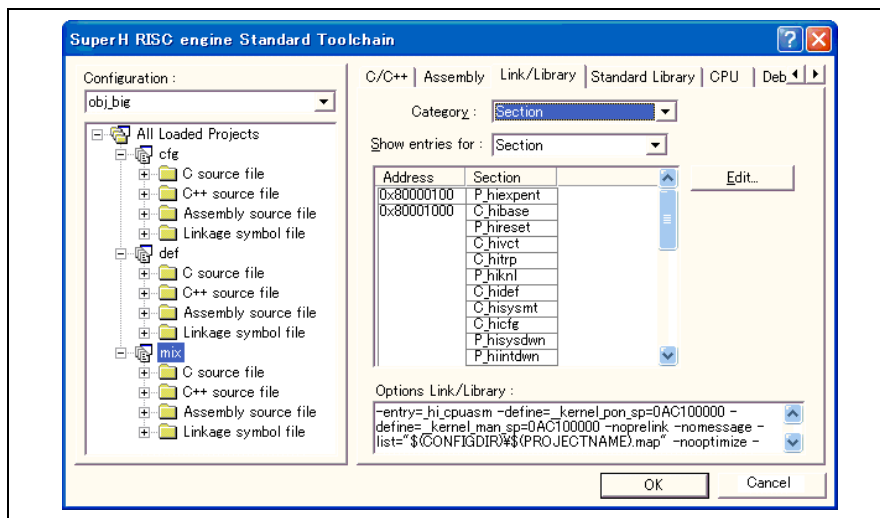

Figure 5.13 Optimized Linkage Editor [Section]

Specifies the allocation addresses of each section. Specify the allocation addresses for the sections in the input files according to the target hardware.

Basically, specify addresses for all sections in the input files. The optimized linkage editor automatically places all sections without overt address specifications after the last section in the input files with such a specification. The resulting arrangement of sections may not produce the order expected, and the program may not work properly. In this case, the optimized linkage editor reports the following warning message (example in case P_Task1 section is not specified).

```
L1120 (W) Section address is not assigned to "P_Task1"
```

Specifying a section name that does not actually appear in the input files also produces a warning message, but the optimized linkage editor continues linking. In this case, the optimized linkage editor reports the following warning message (example in case C section does not exist).

```
L1100 (W) Cannot find "C" specified in option "start"
```

The default settings, for example, sometimes produce such warnings if the application files do not have P, C, D, B, or R sections because these sections are not used in the linked application object, but these warnings in no way affect use of the resulting load module.

Memory Allocation of the HI7000/4:

The vector table (C_hivct section) must be specified. Be sure to allocate the C_hivct section to address 0 when the reset vector is defined through the configurator.

Memory Allocation of the HI7700/4 and the HI7750/4:

Allocate the section (P_hicpuasm) of the CPU initialization routine to H'a0000000 (reset address).

5.12.4 Executing a Build

The load module is created by executing a build after adding application files to the project and setting the compiler, assembler, and optimized linkage editor options. To execute a build, choose the [Build] or [Build All] command from the Build menu as shown in figure 5.14.

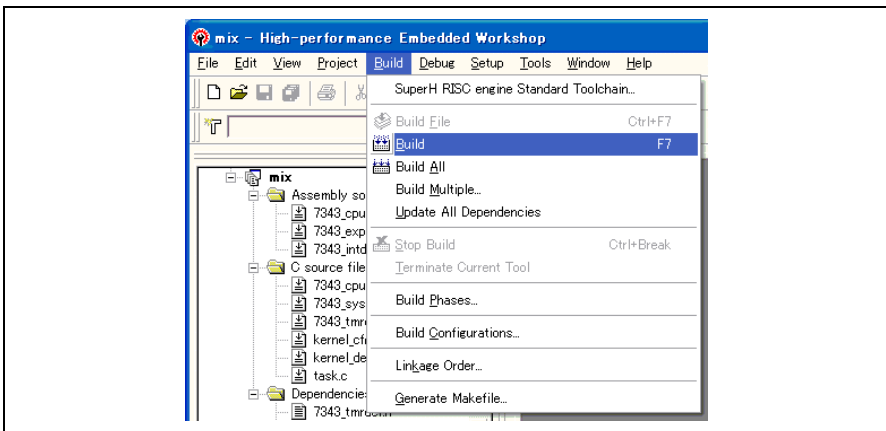

Figure 5.14 Build Execution

5.13 Build for Separate Linkage: Kernel Side (def)

5.13.1 Adding Files to a Project

Table 5.12 lists the source program files to be added to the project. The sample project file already contains the files shown in this table.

Table 5.12 Source Program Files to be Added to the Project (def)

File Name	Description	Notes
kernel_def.c * ¹	Kernel side configuration file	Mandatory
nnnn_sysdwn.c * ¹	System down routine	Mandatory
nnnn_expent.src * ¹ * ²	Interrupt or exception entry/exit routine	Mandatory
nnnn_intdwn.src * ¹ * ²	Undefined interrupt detailed information acquisition process	Mandatory
kernel_exp_src * ¹ * ³	Interrupt or exception processing routine	Mandatory
nnnn_cpuasm.src * ¹ , nnnn_cpui.c * ¹	CPU initialization routine	Mandatory for executing by reset
\\nnnn_tmrv.c * ¹	Standard timer driver	When using optimized timer driver in HI7700/4, do not include this

Application files —

- Notes: 1. These files are in the sh\\nnnn\\src or sh\\nnnn\\project\\src folder.
2. Only in the HI7700/4 and HI7750/4
3. Only in the HI7000/4

5.13.2 Defining Endian (HI7700/4 and HI7750/4)

The endian in the supplied sample project is set by selecting it in the build configuration. Select the build configuration as shown in figure 5.10.

5.13.3 Setting Optimized Linkage Editor Options

(1) [Input] Category, [Library files]

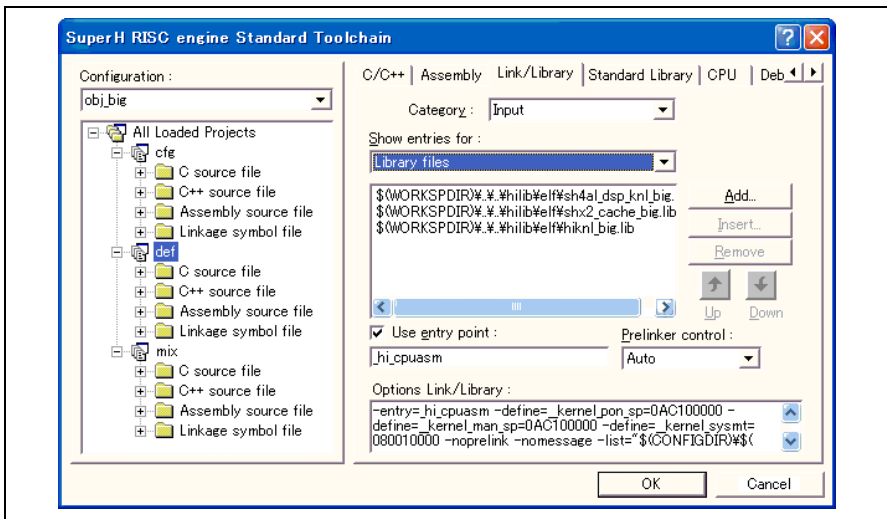

Figure 5.15 Optimized Linkage Editor [Input] Category, [Library files]

Be sure to specify necessary libraries as described in 5.9, Kernel Libraries. Also, specify application libraries as required.

(2) [Input] Category, [Defines]

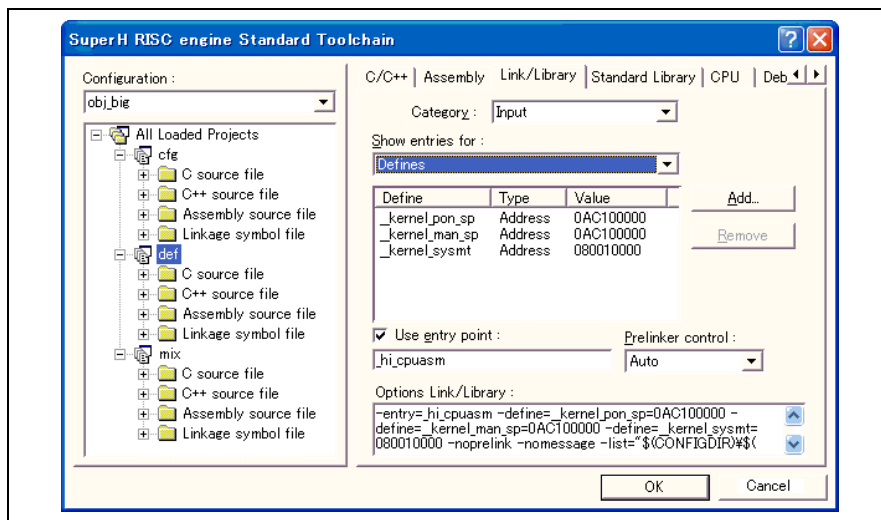

Figure 5.16 Optimized Linkage Editor [Input] Category, [Defines]

The following symbol address is defined.

- `__kernel_sysmt`: Kernel environment information

As this kernel environment information is included in the kernel environment load module (cfg), the kernel environment information allocation address must therefore be forcibly defined.

`__kernel_sysmt` is the start address of the `C_hisysmt` section in the kernel environment side configuration file (kernel_cfg.c). When creating the kernel environment side load module, the `C_hisysmt` section must be allocated to the address defined here.

In the sample file (*mmmm_cpasm.src*) for the HI7700/4 and the HI7750/4, the following symbols are externally referred to, so define them here.

- `__kernel_pon_sp`: Initial stack pointer used for power-on reset
- `__kernel_man_sp`: Initial stack pointer used for manual reset

(3) [Section] Category

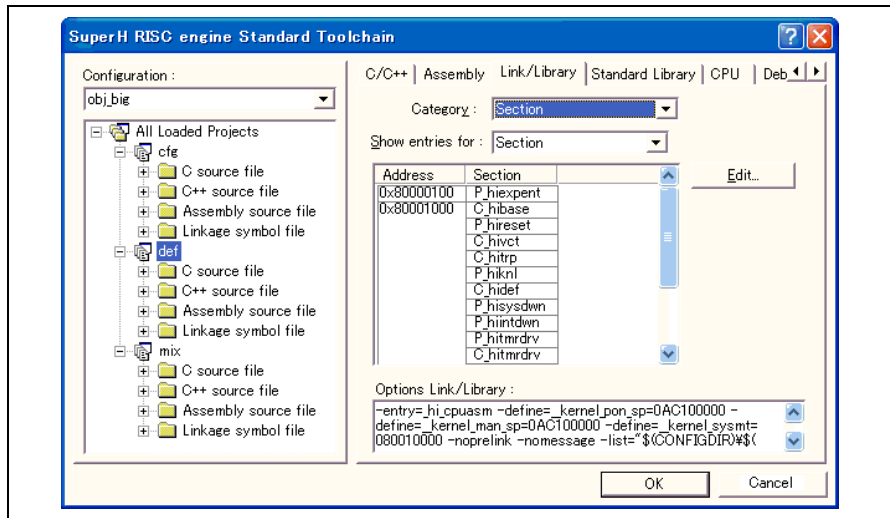

Figure 5.17 Optimized Linkage Editor [Section]

Specifies the allocation addresses of each section. Specify the allocation addresses for the sections in the input files according to the target hardware.

The `__kernel_cnfgtbl` address (the start address of service call interface data `C_hibase` section) must be defined during the kernel environment load module creation (cfg). The defined address and the allocation address of the `C_hibase` section must be the same.

Basically, specify addresses for all sections in the input files. The optimized linkage editor automatically places all sections without overt address specifications after the last section in the input files with such a specification. The resulting arrangement of sections may not produce the order expected, and the program may not work properly. In this case, the optimized linkage editor reports the following warning message (example in case `P_Task1` section is not specified).

```
L1120 (W) Section address is not assigned to "P_Task1"
```

Specifying a section name that does not actually appear in the input files also produces a warning message, but the optimized linkage editor continues linking. In this case, the optimized linkage editor reports the following warning message (example in case `C` section does not exist).

```
L1100 (W) Cannot find "C" specified in option "start"
```

The default settings, for example, sometimes produce such warnings if the application files do not have `P`, `C`, `D`, `B`, or `R` sections because these sections are not used in the linked application object, but these warnings in no way affect use of the resulting load module.

Memory Allocation of the HI7000/4:

The vector table (C_hivct section) must be specified. Be sure to allocate the C_hivct section to address 0 when the reset vector is defined through the configurator.

Memory Allocation of the HI7700/4 and the HI7750/4:

Allocate the section (P_hicpuasm) of the CPU initialization routine to H'a0000000 (reset address).

5.13.4 Executing a Build

The load module is created by executing a build after adding application files to the project and setting the compiler, assembler, and optimized linkage editor options. To execute a build, choose the [Build] or [Build All] command from the Build menu as shown in figure 5.14.

5.14 Build at Separate Linkage: Kernel Environment Side (cfg)

Open the sample workspace (hios.hws) and select the project file (cfg) appropriate to the microcomputer to be used.

5.14.1 Adding Files to a Project

Table 5.13 lists the source program files to be added to the project. The sample project file already contains the files shown in this table.

Table 5.13 Source Program Files to be Recorded in the Project (cfg)

File Name	Description	Notes
kernel_cfg.c *	Kernel environment side configuration file	Mandatory
task.c *	Sample task	
Application files	—	

Note: * These files are in the sh`nnnn`\src or sh`nnnn`\project\src folders.

5.14.2 Defining Endian (HI7700/4 and HI7750/4)

The endian in the supplied sample project is set by selecting it in the build configuration. Select the build configuration as shown in figure 5.10.

5.14.3 Setting Optimized Linkage Editor Options

(1) [Input] Category, [Defines]

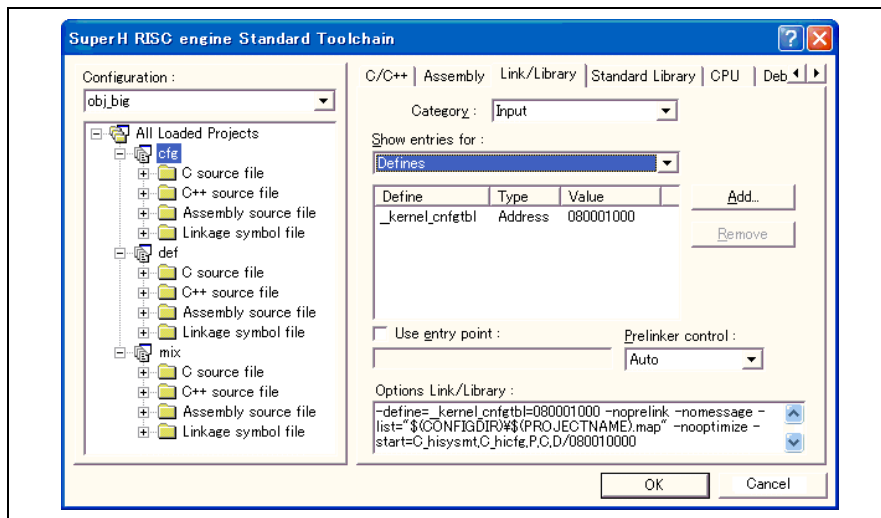

Figure 5.18 Optimized Linkage Editor [Input] Category, [Defines]

The following symbol address is defined.

- `__kernel_cnfgtbl`: Service call interface data

As this service call interface data is included in the kernel load module (def), the service call interface data allocation addresses must therefore be forcibly defined. `__kernel_cnfgtbl` is the start address of the `C_hibase` section in the kernel side configuration file (kernel_def.c).

(2) [Section] Category

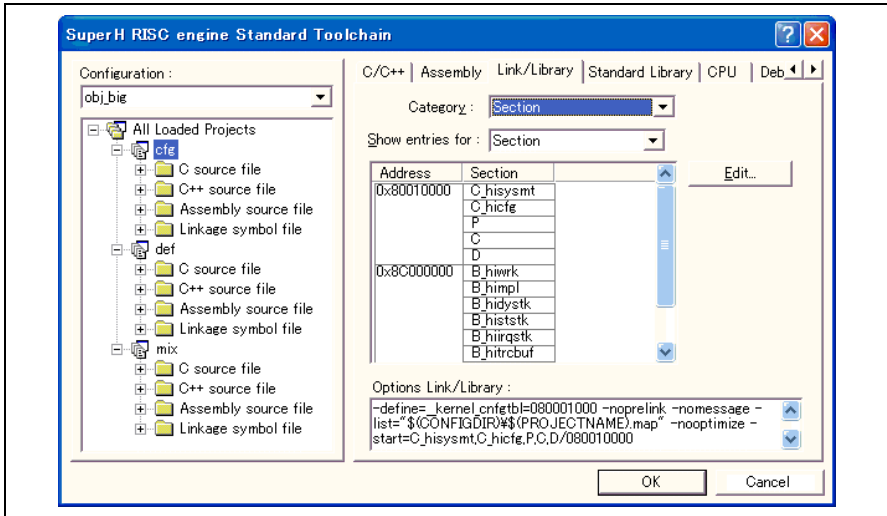

Figure 5.19 Optimized Linkage Editor [Section]

Specifies the allocation addresses of each section. Specify the allocation addresses for the sections in the input files according to the target hardware.

The `__kernel_sysmt` address (the start address of kernel environment information `C_hisysmt` section) must be defined in the kernel load module creation (def). The defined address and the allocation address of the `C_hisysmt` section must be the same.

Basically, specify addresses for all sections in the input files. The optimized linkage editor automatically places all sections without overt address specifications after the last section in the input files with such a specification. The resulting arrangement of sections may not produce the order expected, and the program may not work properly. In this case, the optimized linkage editor reports the following warning message (example in case `P_Task1` section is not specified).

```
L1120 (W) Section address is not assigned to "P_Task1"
```

Specifying a section name that does not actually appear in the input files also produces a warning message, but the optimized linkage editor continues linking. In this case, the optimized linkage editor reports the following warning message (example in case `C` section does not exist).

```
L1100 (W) Cannot find "C" specified in option "start"
```

The default settings, for example, sometimes produce such warnings if the application files do not have `P`, `C`, `D`, `B`, or `R` sections because these sections are not used in the linked application object, but these warnings in no way affect use of the resulting load module.

5.14.4 Executing a Build

The load module is created by executing a build after adding application files to the project and setting the compiler, assembler, and optimized linkage editor options. To execute a build, choose the [Build] or [Build All] command from the Build menu as shown in figure 5.14.

5.15 Application Load Module Creation

Application files that are specified in the configurator and that do not have external application names (such as task symbols) can independently create a load module. Conversely, it is possible to include all application files in a whole load module, kernel load module, or kernel environment load module. In this case, no application load module is required.

To create a new load module with applications alone, see the details of the procedure for adding a new project into the sample workspace (hios.hws) or creating a new workspace, as given in the HEW User's Manual or online help.

Please note the following points for linkage:

(1) Definition of `__kernel cnfgtbl` address

The following symbol address must be defined:

- `__kernel cnfgtbl`: Service call interface data

As this service call interface data is included in the kernel load module (mix or def), the service call interface data allocation address must therefore be forcibly defined. `__kernel_cnfgtbl` is the start address of the `C_hibase` section in the kernel side configuration file (`kernel_def.c`).

Appendix A Service Call List

No.	Service Call	C-Language API	Function
Task Management Function			
1	<u>cre_tsk</u> <u>icre_tsk</u>	ER ercd= cre_tsk (ID tskid, T_CTSK *pk_ctsk); ER ercd= icre_tsk (ID tskid, T_CTSK *pk_ctsk);	Create Task Using Dynamic Stack
2	<u>vscr_tsk</u> <u>ivscr_tsk</u>	ER ercd= vscr_tsk (ID tskid, T_CTSK *pk_ctsk); ER ercd= ivscr_tsk (ID tskid, T_CTSK *pk_ctsk);	Create Task Using Static Stack
3	<u>acre_tsk</u> <u>iacre_tsk</u>	ER_ID tskid= acre_tsk (T_CTSK *pk_ctsk); ER_ID tskid= iacre_tsk (T_CTSK *pk_ctsk);	Create Task and Assign Task ID Automatically
4	<u>del_tsk</u>	ER ercd= del_tsk (ID tskid);	Delete Task
5	<u>act_tsk</u> <u>iact_tsk</u>	ER ercd= act_tsk (ID tskid); ER ercd= iact_tsk (ID tskid);	Initiate Task
6	<u>can_act</u> <u>ican_act</u>	ER_UINT actcnt= can_act (ID tskid); ER_UINT actcnt= ican_act (ID tskid);	Cancel Task Initiation Request
7	<u>sta_tsk</u> <u>ista_tsk</u>	ER ercd= sta_tsk (ID tskid, VP_INT stacd); ER ercd= ista_tsk (ID tskid, VP_INT stacd);	Start Task (Start Code Specified)
8	<u>ext_tsk</u>	void ext_tsk (void);	Exit Current Task
9	<u>exd_tsk</u>	void exd_tsk (void);	Exit and Delete Current Task
10	<u>ter_tsk</u>	ER ercd= ter_tsk (ID tskid);	Terminate Task
11	<u>chg_pri</u> <u>ichg_pri</u>	ER ercd= chg_pri (ID tskid, PRI tskpri); ER ercd= ichg_pri (ID tskid, PRI tskpri);	Change Task Priority
12	<u>get_pri</u> <u>iget_pri</u>	ER ercd= get_pri (ID tskid, PRI *p_tskpri); ER ercd= iget_pri (ID tskid, PRI *p_tskpri);	Refer to Task Priority
13	<u>ref_tsk</u> <u>iref_tsk</u>	ER ercd= ref_tsk (ID tskid, T_RTST *pk_rtst); ER ercd= iref_tsk (ID tskid, T_RTST *pk_rtst);	Refer to Task State
14	<u>ref_tst</u> <u>iref_tst</u>	ER ercd= ref_tst (ID tskid T_RTST *pk_rtst); ER ercd= iref_tst (ID tskid T_RTST *pk_rtst);	Refer to Task State (simple version)
15	<u>vchg_tmd</u>	ER ercd= vchg_tmd (UINT tmd);	Change Task Execution Mode

Appendix A Service Call List

No.	Service Call	C-Language API	Function
Task Synchronous Management Function			
16	slp_tsk	ER ercd= slp_tsk (void);	Sleep Task
17	tslp_tsk	ER ercd= tslp_tsk (TMO tmout);	Sleep Task with Timeout
18	wup_tsk iwup_tsk	ER ercd= wup_tsk (ID tskid); ER ercd= iwup_tsk (ID tskid);	Wakeup Task
19	can_wup ican_wup	ER UINT wupcnt= can_wup (ID tskid); ER UINT wupcnt= ican_wup (ID tskid);	Cancel Wakeup Task
20	rel_wai irel_wai	ER ercd= rel_wai (ID tskid); ER ercd= irel_wai (ID tskid);	Release WAITING State Forcibly
21	sus_tsk isus_tsk	ER ercd= sus_tsk (ID tskid); ER ercd= isus_tsk (ID tskid);	Shift to SUSPENDED State
22	rsm_tsk irms_tsk	ER ercd= rsm_tsk (ID tskid); ER ercd= irsm_tsk (ID tskid);	Resume Task from SUSPENDED State
23	frsm_tsk ifrm_tsk	ER ercd= frsm_tsk (ID tskid); ER ercd= ifrm_tsk (ID tskid);	Resume Task from SUSPENDED State Forcibly
24	dly_tsk	ER ercd= dly_tsk (RELTIM dlytim);	Delay Task
25	vset_tfl ivset_tfl	ER ercd= vset_tfl (ID tskid, UINT setptn); ER ercd= ivset_tfl (ID tskid, UINT setptn);	Set Task Event Flag
26	vclr_tfl ivclr_tfl	ER ercd= vclr_tfl (ID tskid, UINT clrptn); ER ercd= ivclr_tfl (ID tskid, UINT clrptn);	Clear Task Event Flag
27	vwai_tfl	ER ercd= vwai_tfl (UINT waiptn, UINT *p_tflptn);	Wait Task Event Flag
28	vpol_tfl	ER ercd= vpol_tfl (UINT waiptn, UINT *p_tflptn);	Poll and Wait Task Event Flag
29	vtwai_tfl	ER ercd= vtwai_tfl (UINT waiptn, UINT *p_tflptn, TMO tmout);	Wait Task Event Flag with Timeout

No.	Service Call	C-Language API	Function
Task Exception Management Function			
30	<u>def_tex</u>	ER ercd= def_tex (ID tskid, T_DTEX *pk_dtex);	Define Task Exception Processing Routine
	<u>idef_tex</u>	ER ercd= idef_tex (ID tskid, T_DTEX *pk_dtex);	
31	<u>ras_tex</u>	ER ercd= ras_tex (ID tskid, TEXPTN rasptn);	Request Task Exception Processing
	<u>iras_tex</u>	ER ercd= iras_tex (ID tskid, TEXPTN rasptn);	
32	<u>dis_tex</u>	ER ercd= dis_tex (void);	Disable Task Exception Processing
33	<u>ena_tex</u>	ER ercd= ena_tex (void);	Enable Task Exception Processing
34	<u>sns_tex</u>	BOOL state= sns_tex (void);	Refer to Task Exception Processing Disabled State
35	<u>ref_tex</u>	ER ercd= ref_tex (ID tskid, T_RTEX *pk_rtex);	Refer to Task Exception Processing State
	<u>iref_tex</u>	ER ercd= iref_tex (ID tskid, T_RTEX *pk_rtex);	
Synchronization and Communication Function			
Semaphore			
36	<u>cre_sem</u>	ER ercd= cre_sem (ID semid, T_CSEM *pk_csem);	Create Semaphore
	<u>icre_sem</u>	ER ercd= icre_sem (ID semid, T_CSEM *pk_csem);	
37	<u>acre_sem</u>	ER_ID semid= acre_sem (T_CSEM *pk_csem);	Create Semaphore and Assign Semaphore ID Automatically
	<u>iacre_sem</u>	ER_ID semid= iacre_sem (T_CSEM *pk_csem);	
38	<u>del_sem</u>	ER ercd= del_sem (ID semid);	Delete Semaphore
39	<u>sig_sem</u>	ER ercd= sig_sem (ID semid);	Return Semaphore Resource
	<u>isig_sem</u>	ER ercd= isig_sem (ID semid);	
40	<u>wai_sem</u>	ER ercd= wai_sem (ID semid);	Wait on Semaphore
41	<u>pol_sem</u>	ER ercd= pol_sem (ID semid);	Poll and Wait on Semaphore
	<u>ipol_sem</u>	ER ercd= ipol_sem (ID semid);	
42	<u>twai_sem</u>	ER ercd= twai_sem (ID semid, TMO tmout);	Wait on Semaphore with Timeout
43	<u>ref_sem</u>	ER ercd= ref_sem (ID semid, T_RSEM *pk_rsem);	Refer to Semaphore State
	<u>iref_sem</u>	ER ercd= iref_sem (ID semid, T_RSEM *pk_rsem);	

Appendix A Service Call List

No.	Service Call	C-Language API	Function
Event Flag			
44	cre_flg	ER ercd= cre_flg (ID flgid, T_CFLG *pk_cflg);	Create Event Flag
	icre_flg	ER ercd= icre_flg (ID flgid, T_CFLG *pk_cflg);	
45	acre_flg	ER_ID flgid= acre_flg (T_CFLG *pk_cflg);	Create Event Flag and Assign Event Flag ID Automatically
	iacre_flg	ER_ID flgid= iacre_flg (T_CFLG *pk_cflg);	
46	del_flg	ER ercd= del_flg (ID flgid);	Delete Event Flag
47	set_flg	ER ercd= set_flg (ID flgid, FLGPTN setptn);	Set Event Flag
	iset_flg	ER ercd= iset_flg (ID flgid, FLGPTN setptn);	
48	clr_flg	ER ercd= clr_flg (ID flgid, FLGPTN clrptn);	Clear Event Flag
	iclr_flg	ER ercd= iclr_flg (ID flgid, FLGPTN clrptn);	
49	wai_flg	ER ercd= wai_flg (ID flgid, FLGPTN waiptn, MODE wfmode, FLGPTN *p_flgptn);	Wait for Event Flag Setting
50	pol_flg	ER ercd= pol_flg (ID flgid, FLGPTN waiptn, MODE wfmode, FLGPTN *p_flgptn);	Poll and Wait for Event Flag Setting
	ipol_flg	ER ercd= ipol_flg (ID flgid, FLGPTN waiptn, MODE wfmode, FLGPTN *p_flgptn);	
51	twai_flg	ER ercd= twai_flg (ID flgid, FLGPTN waiptn, MODE wfmode, FLGPTN *p_flgptn, TMO tmout);	Wait for Event Flag Setting with Timeout
52	ref_flg	ER ercd= ref_flg (ID flgid, T_RFLG *pk_rflg);	Refer to Event Flag State
	iref_flg	ER ercd= iref_flg (ID flgid, T_RFLG *pk_rflg);	
Data Queue			
53	cre_dtq	ER ercd= cre_dtq (ID dtqid, T_CDTQ *pk_cdtq);	Create Data Queue
	icre_dtq	ER ercd= icre_dtq (ID dtqid, T_CDTQ *pk_cdtq);	
54	acre_dtq	ER_ID dtqid= acre_dtq (T_CDTQ *pk_cdtq);	Create Data Queue and Assign Data Queue ID Automatically
	iacre_dtq	ER_ID dtqid= iacre_dtq (T_CDTQ *pk_cdtq);	
55	del_dtq	ER ercd= del_dtq (ID dtqid);	Delete Data Queue
56	snd_dtq	ER ercd= snd_dtq (ID dtqid, VP_INT data);	Send Data to Data Queue
57	psnd_dtq	ER ercd= psnd_dtq (ID dtqid, VP_INT data);	Poll and Send Data to Data Queue
	ipsnd_dtq	ER ercd= ipsnd_dtq (ID dtqid, VP_INT data);	

No.	Service Call C-Language API	Function
58	tsnd_dtq ER ercd= tsnd_dtq (ID dtqid, VP_INT data, TMO tmout);	Send Data to Data Queue with Timeout
59	fsnd_dtq ER ercd= fsnd_dtq (ID dtqid, VP_INT data); ifsnd_dtq ER ercd= ifsnd_dtq (ID dtqid, VP_INT data);	Send Data to Data Queue Forcibly
60	rcv_dtq ER ercd= rcv_dtq (ID dtqid, VP_INT *p_data);	Receive Data from Data Queue
61	prcv_dtq ER ercd= prcv_dtq (ID dtqid, VP_INT *p_data);	Poll and Receive Data from Data Queue
62	trcv_dtq ER ercd= trcv_dtq (ID dtqid, VP_INT *p_data, TMO tmout);	Receive Data from Data Queue with Timeout
63	ref_dtq ER ercd= ref_dtq (ID dtqid, T_RDTQ *pk_rdtq); iref_dtq ER ercd= iref_dtq (ID dtqid, T_RDTQ *pk_rdtq);	Refer to Data Queue State
Mailbox		
64	cre_mbx ER ercd= cre_mbx (ID mbxid, T_CMBX *pk_cmbx); icre_mbx ER ercd= icre_mbx (ID mbxid, T_CMBX *pk_cmbx);	Create Mailbox
65	acre_mbx ER_ID mbxid= acre_mbx (T_CMBX *pk_cmbx); iacre_mbx ER_ID mbxid= iacre_mbx (T_CMBX *pk_cmbx);	Create Mailbox and Assign Mailbox ID Automatically
66	del_mbx ER ercd= del_mbx (ID mbxid);	Delete Mailbox
67	snd_mbx ER ercd= snd_mbx (ID mbxid, T_MSG *pk_msg); isnd_mbx ER ercd= isnd_mbx (ID mbxid, T_MSG *pk_msg);	Send Message to Mailbox
68	rcv_mbx ER ercd= rcv_mbx (ID mbxid, T_MSG **ppk_msg);	Receive Message from Mailbox
69	prcv_mbx ER ercd= prcv_mbx (ID mbxid, T_MSG **ppk_msg); iprcv_mbx ER ercd= iprcv_mbx (ID mbxid, T_MSG **ppk_msg);	Poll and Receive Message from Mailbox
70	trcv_mbx ER ercd= trcv_mbx (ID mbxid, T_MSG **ppk_msg, TMO tmout);	Receive Message from Mailbox with Timeout
71	ref_mbx ER ercd= ref_mbx (ID mbxid, T_RMBX *pk_rmbx); iref_mbx ER ercd= iref_mbx (ID mbxid, T_RMBX *pk_rmbx);	Refer to Mailbox State

No.	Service Call	C-Language API	Function
Extended Synchronization and Communication Function			
Mutex			
72	cre_mtx	ER ercd= cre_mtx (ID mtxid, T_CMTX *pk_cmtx);	Create Mutex
73	acre_mtx	ER_ID mtxid= acre_mtx (T_CMTX *pk_cmtx);	Create Mutex and Assign Mutex ID Automatically
74	del_mtx	ER ercd= del_mtx (ID mtxid);	Delete Mutex
75	loc_mtx	ER ercd= loc_mtx (ID mtxid);	Lock Mutex Resource
76	ploc_mtx	ER ercd= ploc_mtx (ID mtxid);	Poll and Lock Mutex Resource
77	tlloc_mtx	ER ercd= tlloc_mtx (ID mtxid, TMO tmout);	Lock Mutex Resource with Timeout
78	unl_mtx	ER ercd= unl_mtx (ID mtxid);	Unlock Mutex Resource
79	ref_mtx	ER ercd= ref_mtx (ID mtxid, T_RMTX *pk_rmtx);	Refer to Mutex State
Message Buffer			
80	cre_mbf	ER ercd= cre_mbf (ID mbfid, T_CMBF *pk_cmbf);	Create Message Buffer
	icre_mbf	ER ercd= icre_mbf (ID mbfid, T_CMBF *pk_cmbf);	
81	acre_mbf	ER_ID mbfid= acre_mbf (T_CMBF *pk_cmbf);	Create Message Buffer and Assign Message Buffer ID Automatically
	iacre_mbf	ER_ID mbfid= iacre_mbf (T_CMBF *pk_cmbf);	
82	del_mbf	ER ercd= del_mbf (ID mbfid);	Delete Message Buffer
83	snd_mbf	ER ercd= snd_mbf (ID mbfid, VP msg, UINT msgsz);	Send Message to Message Buffer
84	psnd_mbf	ER ercd= psnd_mbf (ID mbfid, VP msg, UINT msgsz);	Poll and Send Message to Message Buffer
	ipsnd_mbf	ER ercd= ipsnd_mbf (ID mbfid, VP msg, UINT msgsz);	
85	tsnd_mbf	ER ercd= tsnd_mbf (ID mbfid, VP msg, UINT msgsz, TMO tmout);	Send Message to Message Buffer with Timeout
86	rcv_mbf	ER_UINT msgsz= rcv_mbf (ID mbfid, VP msg);	Receive Message from Message Buffer
87	prcv_mbf	ER_UINT msgsz= prcv_mbf (ID mbfid, VP msg);	Poll and Receive Message from Message Buffer
88	trcv_mbf	ER_UINT msgsz= trcv_mbf (ID mbfid, VP msg, TMO tmout);	Receive Message from Message Buffer with Timeout
89	ref_mbf	ER ercd= ref_mbf (ID mbfid, T_RMBF *pk_rmbf);	Refer to Message Buffer State
	iref_mbf	ER ercd= iref_mbf (ID mbfid, T_RMBF *pk_rmbf);	

No.	Service Call	C-Language API	Function
Memory Pool Management Function			
Fixed-Size Memory Pool			
90	cre_mpf icre_mpf	ER ercd= cre_mpf (ID mpfid, T_CMPF *pk_cmpf); ER ercd= icre_mpf (ID mpfid, T_CMPF *pk_cmpf);	Create Fixed-Size Memory Pool
91	acre_mpf iacre_mpf	ER_ID mpfid= acre_mpf (T_CMPF *pk_cmpf); ER_ID mpfid= iacre_mpf (T_CMPF *pk_cmpf);	Create Fixed-Size Memory Pool and Assign Fixed-Size Memory Pool ID Automatically
92	del_mpf	ER ercd= del_mpf (ID mpfid);	Delete Fixed-Size Memory Pool
93	get_mpf	ER ercd= get_mpf (ID mpfid, VP *p_blk);	Acquire Fixed-Size Memory Block
94	pget_mpf ipget_mpf	ER ercd= pget_mpf (ID mpfid, VP *p_blk); ER ercd= ipget_mpf (ID mpfid, VP *p_blk);	Poll and Acquire Fixed-size Memory Block
95	tget_mpf	ER ercd= tget_mpf (ID mpfid, VP *p_blk, TMO tmout);	Acquire Fixed-Size Memory Block with Timeout
96	rel_mpf irel_mpf	ER ercd= rel_mpf (ID mpfid, VP blk); ER ercd= irel_mpf (ID mpfid, VP blk);	Release Fixed-Size Memory Block
97	ref_mpf iref_mpf	ER ercd= ref_mpf (ID mpfid, T_RMPF *pk_rmpf); ER ercd= iref_mpf (ID mpfid, T_RMPF *pk_rmpf);	Refer to Fixed-Size Memory Pool State
Variable-Size Memory Pool			
98	cre_mpl icre_mpl	ER ercd= cre_mpl (ID mplid, T_CMPL *pk_cmpl); ER ercd= icre_mpl (ID mplid, T_CMPL *pk_cmpl);	Create Variable-Size Memory Pool
99	acre_mpl iacre_mpl	ER_ID mplid= acre_mpl (T_CMPL *pk_cmpl); ER_ID mplid= iacre_mpl (T_CMPL *pk_cmpl);	Create Variable-Size Memory Pool and Assign Variable-Size Memory Pool ID Automatically
100	del_mpl	ER ercd= del_mpl (ID mplid);	Delete Variable-Size Memory Pool
101	get_mpl	ER ercd= get_mpl (ID mplid, UINT blkksz, VP *p_blk);	Acquire Variable-Size Memory Block
102	pget_mpl ipget_mpl	ER ercd= pget_mpl (ID mplid, UINT blkksz, VP *p_blk); ER ercd= ipget_mpl (ID mplid, UINT blkksz, VP *p_blk);	Poll and Acquire Variable-Size Memory Block
103	tget_mpl	ER ercd= tget_mpl (ID mplid, UINT blkksz, VP *p_blk, TMO tmout);	Acquire Variable-Size Memory Block with Timeout
104	rel_mpl irel_mpl	ER ercd= rel_mpl (ID mplid, VP blk); ER ercd= irel_mpl (ID mplid, VP blk);	Release Variable-Size Memory Block
105	ref_mpl iref_mpl	ER ercd= ref_mpl (ID mplid, T_RMPL *pk_rmpl); ER ercd= iref_mpl (ID mplid, T_RMPL *pk_rmpl);	Refer to Variable-Size Memory Pool State

No.	Service Call	C-Language API	Function
Time Management Function			
System Clock Management			
106	set_tim iset_tim	ER ercd= set_tim (SYSTIM *p_systim); ER ercd= iset_tim (SYSTIM *p_systim);	Set System Clock
107	get_tim iget_tim	ER ercd= get_tim (SYSTIM *p_systim); ER ercd= iget_tim (SYSTIM *p_systim);	Get System Clock
108	isig_tim	Included automatically by selecting CFG_TIMUSE	Supply Time Tick
Cyclic Handler			
109	cre_cyc icre_cyc	ER ercd= cre_cyc (ID cycid, T_CCYC *pk_ccyc); ER ercd= icre_cyc (ID cycid, T_CCYC *pk_ccyc);	Create Cyclic Handler
110	acre_cyc iacre_cyc	ER_ID cycid= acre_cyc (T_CCYC *pk_ccyc); ER_ID cycid= iacre_cyc (T_CCYC *pk_ccyc);	Create Cyclic Handler and Assign Cyclic Handler ID Automatically
111	del_cyc	ER ercd= del_cyc (ID cycid);	Delete Cyclic Handler
112	sta_cyc ista_cyc	ER ercd= sta_cyc (ID cycid); ER ercd= ista_cyc (ID cycid);	Start Cyclic Handler
113	stp_cyc istp_cyc	ER ercd= stp_cyc (ID cycid); ER ercd= istp_cyc (ID cycid);	Stop Cyclic Handler
114	ref_cyc iref_cyc	ER ercd= ref_cyc (ID cycid, T_RCYC *pk_rcyc); ER ercd= iref_cyc (ID cycid, T_RCYC *pk_rcyc);	Refer to Cyclic Handler State
Alarm Handler			
115	cre_alm icre_alm	ER ercd= cre_alm (ID almid, T_CALM *pk_calm); ER ercd= icre_alm (ID almid, T_CALM *pk_calm);	Create Alarm Handler
116	acre_alm iacre_alm	ER_ID almid= acre_alm (T_CALM *pk_calm); ER_ID almid= iacre_alm (T_CALM *pk_calm);	Create Alarm Handler and Assign Alarm Handler ID Automatically
117	del_alm	ER ercd= del_alm (ID almid);	Delete Alarm Handler
118	sta_alm ista_alm	ER ercd= sta_alm (ID almid, RELTIM almtim); ER ercd= ista_alm (ID almid, RELTIM almtim);	Start Alarm Handler
119	stp_alm istp_alm	ER ercd= stp_alm (ID almid); ER ercd= istp_alm (ID almid);	Stop Alarm Handler
120	ref_alm iref_alm	ER ercd= ref_alm (ID almid, T_RALM *pk_ralm); ER ercd= iref_alm (ID almid, T_RALM *pk_ralm);	Refer to Alarm Handler State

No.	Service Call	C-Language API	Function
Overrun Handler			
121	def_ovr	ER ercd= def_ovr (T_DOVR *pk_dovr);	Define Overrun Handler
122	sta_ovr	ER ercd= sta_ovr (ID tskid, OVRTIM ovrtime);	Start Overrun Handler Operation
	ista_ovr	ER ercd= ista_ovr (ID tskid, OVRTIM ovrtime);	
123	stp_ovr	ER ercd= stp_ovr (ID tskid);	Stop Overrun Handler Operation
	istp_ovr	ER ercd= istp_ovr (ID tskid);	
124	ref_ovr	ER ercd= ref_ovr (ID tskid, T_ROVR *pk_rovr);	Refer to Overrun Handler State
	iref_ovr	ER ercd= iref_ovr (ID tskid, T_ROVR *pk_rovr);	

System Status Management Function

125	rot_rdq	ER ercd= rot_rdq (PRI tskpri);	Rotate Ready Queue
	irotd_rdq	ER ercd= irotd_rdq (PRI tskpri);	
126	get_tid	ER ercd= get_tid (ID *p_tskid);	Refer to Task ID in RUNNING State
	iget_tid	ER ercd= iget_tid (ID *p_tskid);	
127	loc_cpu	ER ercd= loc_cpu (void);	Lock CPU
	iloc_cpu	ER ercd= iloc_cpu (void);	
128	unl_cpu	ER ercd= unl_cpu (void);	Unlock CPU
	iunl_cpu	ER ercd= iunl_cpu (void);	
129	dis_dsp	ER ercd= dis_dsp (void);	Disable Dispatch
130	ena_dsp	ER ercd= ena_dsp (void);	Enable Dispatch
131	sns_ctx	BOOL state= sns_ctx (void);	Refer to Context
132	sns_loc	BOOL state= sns_loc (void);	Refer to CPU-Locked State
133	sns_dsp	BOOL state= sns_dsp (void);	Refer to Dispatch-Disabled State
134	sns_dpn	BOOL state= sns_dpn (void);	Refer to Dispatch-Pended State

Appendix A Service Call List

No.	Service Call	C-Language API	Function
135	<u>vsta_knl</u> ivsta_knl	void vsta_knl (void); void ivsta_knl (void);	Start Kernel
136	<u>vsys_dwn</u> ivsys_dwn	void vsys_dwn (W type, ER ercd, VW inf1, VW inf2); void ivsys_dwn (W type, ER ercd, VW inf1, VW inf2);	Terminate System
137	<u>vget_trc</u> ivget_trc	ER ercd= vget_trc (VW para1, VW para2, VW para3, VW para4); ER ercd= ivget_trc (VW para1, VW para2, VW para3, VW para4);	Acquire Trace Information
138	<u>ivbgn_int</u>	ER ercd= ivbgn_int (UINT dintno);	Acquire Start of Interrupt Handler as Trace Information
139	<u>ivend_int</u>	ER ercd= ivend_int (UINT dintno);	Acquire End of Interrupt Handler as Trace Information

Interrupt Management Function

140	<u>def_inh</u> idef_inh	ER ercd= def_inh (INHNO inhno, T_DINH *pk_dinh); ER ercd= idef_inh (INHNO inhno, T_DINH *pk_dinh);	Define Interrupt Handler
141	<u>chg_ims</u> ichg_ims	ER ercd= chg_ims (IMASK imask); ER ercd= ichg_ims (IMASK imask);	Change Interrupt Mask
142	<u>get_ims</u> iget_ims	ER ercd= get_ims (IMASK *p_ims); ER ercd= iget_ims (IMASK *p_ims);	Refer to Interrupt Mask

Service Call Management Function

143	<u>def_svc</u> idef_svc	ER ercd= def_svc (FN fnct, T_DSVC *pk_dsvc); ER ercd= idef_svc (FN fnct, T_DSVC *pk_dsvc);	Define Extended Service call Routine
144	<u>cal_svc</u> ical_svc	ER_UINT ercd= cal_svc (FN fnct, ...); ER_UINT ercd= cal_svc (FN fnct, ...);	Extended Service call

No.	Service Call	C-Language API	Function
System Configuration Management Function			
145	def_exc	ER ercd= def_exc (EXCNO excno, T_DEXC *pk_dexc);	Define CPU Exception Handler
	idef_exc	ER ercd= idef_exc (EXCNO excno, T_DEXC *pk_dexc);	
146	vdef_trp	ER ercd= vdef_trp (UINT dtrpno, T_DTRP *pk_dtrp);	Define CPU Exception (TRAPA Instruction Exception) Handler
	ivdef_trp	ER ercd= ivdef_trp (UINT dtrpno, T_DTRP *pk_dtrp);	
147	ref_cfg	ER ercd= ref_cfg (T_RCFCG *pk_rcfg);	Refer to Configuration Information
	iref_cfg	ER ercd= iref_cfg (T_RCFCG *pk_rcfg);	
148	ref_ver	ER ercd= ref_ver (T_RVER *pk_rver);	Refer to Version Information
	iref_ver	ER ercd= iref_ver (T_RVER *pk_rver);	

Cache Support Function [HI7700/4:for SH-3 and SH3-DSP]

149	vini_cac	void vini_cac (UW ccr_data, UW entnum, UW waynum);	Initialize Cache
	ivini_cac	void ivini_cac (UW ccr_data, UW entnum, UW waynum);	
150	vclr_cac	ER ercd= vclr_cac (VP clradr1, VP clradr2);	Clear Cache
	ivclr_cac	ER ercd= ivclr_cac (VP clradr1, VP clradr2);	
151	vfls_cac	ER ercd= vfls_cac (VP flsadr1, VP flsadr2);	Flush Cache
	ivfls_cac	ER ercd= ivfls_cac (VP flsadr1, VP flsadr2);	
152	vinv_cac	ER ercd= vinv_cac (void);	Invalidate Cache
	ivinv_cac	ER ercd= ivinv_cac (void);	

Cache Support Function [HI7750/4:for SH-4]

153	vini_cac	void vini_cac (UW ccr_data);	Initialize Cache
	ivini_cac	void ivini_cac (UW ccr_data);	
154	vclr_cac	ER ercd= vclr_cac (VP clradr1, VP clradr2);	Clear Operand Cache
	ivclr_cac	ER ercd= ivclr_cac (VP clradr1, VP clradr2);	
155	vfls_cac	ER ercd= vfls_cac (VP flsadr1, VP flsadr2);	Flush Operand Cache
	ivfls_cac	ER ercd= ivfls_cac (VP flsadr1, VP flsadr2);	
156	vinv_cac	ER ercd= vinv_cac (VP invadr1, VP invadr2);	Invalidate Operand Cache
	ivinv_cac	ER ercd= ivinv_cac (VP invadr1, VP invadr2);	

No.	Service Call	C-Language API	Function
Cache Support Function [HI7700/4:for SH4AL-DSP without extended function, HI7750/4:for SH-4A without extended function]			
157	vini_cac ivini_cac	ER vini_cac (ATR cacatr); ER ivini_cac (ATR cacatr);	Initialize Cache
158	vclr_cac ivclr_cac	ER ercd= vclr_cac (VP clradr1, VP clradr2, MODE mode); ER ercd= ivclr_cac (VP clradr1, VP clradr2, MODE mode);	Clear Instruction/Operand Cache
159	vfls_cac ivfls_cac	ER ercd= vfls_cac (VP flsadr1, VP flsadr2); ER ercd= ivfls_cac (VP flsadr1, VP flsadr2);	Flush Operand Cache
160	vinv_cac ivinv_cac	ER ercd= vinv_cac (VP invadr1, VP invadr2, MODE mode); ER ercd= ivinv_cac (VP invadr1, VP invadr2, MODE mode);	Invalidate Instruction/Operand Cache
Cache Support Function [HI7700/4:for SH4AL-DSP with extended function, HI7750/4:for SH-4A with extended function]			
161	vini_cac ivini_cac	ER vini_cac (ATR cacatr); ER ivini_cac (ATR cacatr);	Initialize Cache
162	vclr_cac ivclr_cac	ER ercd= vclr_cac (VP clradr1, VP clradr2, MODE mode); ER ercd= ivclr_cac (VP clradr1, VP clradr2, MODE mode);	Clear Instruction/Operand Cache
163	vfls_cac ivfls_cac	ER ercd= vfls_cac (VP flsadr1, VP flsadr2); ER ercd= ivfls_cac (VP flsadr1, VP flsadr2);	Flush Operand Cache
164	vinv_cac ivinv_cac	ER ercd= vinv_cac (VP invadr1, VP invadr2, MODE mode); ER ercd= ivinv_cac (VP invadr1, VP invadr2, MODE mode);	Invalidate Instruction/Operand Cache
DSP Standby Control Function [HI7700/4]			
165	vchg_cop	ER_UINT oldatr = vchg_cop(ATR newatr);	Change TA_COP0 attribute

Appendix B Error List

B.1 Service Call Error Code List

Table B.1 Service Call Error Code List

Error Code (Mnemonic)	Error Code	Error Check Type * Error Contents
1 E_OK	H'00000000 (D'0)	[k] Normal end
2 E_NOSPT	H'ffffff7 (-D'9)	[p] Unsupported function (function is undefined)
3 E_RSFN	H'ffffff6 (-D'10)	[p] No service call is included
4 E_RSATR	H'ffffff5 (-D'11)	[p] Reserved attribute (invalid attribute)
5 E_PAR	H'fffffef (-D'17)	[p]/[k] Parameter error
6 E_ID	H'fffffee (-D'18)	[p] Invalid ID number
7 E_CTX	H'fffffe7 (-D'25)	[k] Context error
8 E_ILUSE	H'fffffe4 (-D'28)	[k] Illegal use of service call
9 E_NOMEM	H'fffffdf (-D'33)	[k] Insufficient memory
10 E_NOID	H'fffffde (-D'34)	[k] No ID available
11 E_OBJ	H'fffffd7 (-D'41)	[k] Object state is invalid
12 E_NOEXS	H'fffffd6 (-D'42)	[k] Object does not exist
13 E_QOVR	H'fffffd5 (-D'43)	[k] Queuing or nest overflow
14 E_RLWAI	H'fffffcf (-D'49)	[k] WAITING state is forcibly cancelled
15 E_TMOUT	H'fffffce (-D'50)	[k] Polling failed or timeout
16 E_DLT	H'fffffcd (-D'51)	[k] Waiting object deleted

Note: [p] is an error that is checked when the parameter checking function (CFG_PARCHK) is selected by the setup file. [k] is an error that is always checked.

B.2 Information during System Down

The system down routine is called when the system goes down. Information listed in table B.2 is passed to the system down routine.

Table B.2 Information Passed to the System Down Routine

Cause of System Going Down	Parameters Passed to the System Down Routine			
	Error Type W type (R4)	Error Code ER ercd (R5)	System Down Information 1 VW inf1 (R6)	System Down Information 2 VW inf2 (R7)
Service call vsys_dwn	1 to H'7ffffff	Parameter of service call vsys_dwn		
An error in the original definition of configurator	0	Error code	0: Error in kernel side 1: Error in kernel environment side	Indicates the definition number where an initial definition error has occurred in the kernel side or kernel environment side ²
When a context error occurred as a result of service call ext_tsk being issued by the non-task context	H'ffffff (-1)	E_CTX (H'ffffffe7)	Address calling ext_tsk	Undefined
When a context error occurred as a result of service call exd_tsk being issued by the non-task context	H'ffffffe (-2)	E_CTX (H'ffffffe7)	Address calling exd_tsk	Undefined
When an undefined interrupt or an exception occurred	H'ffffff0 (-16)	Exception code or vector number ¹	PC at exception occurrence	SR at exception occurrence

- Notes:
1. Information saved by the CPU to the interrupt event register (INTEVT or INTEVT2) or exception event register (EXPEVT) when an interrupt, exception, or unconditional trap occurs on the HI7700/4 and HI7750/4.
 2. The initial definition is processed on the kernel side, and then on the kernel environment side. The order of initial definition on the kernel side and kernel environment side is shown below. The orders of each process are the orders that are listed in each page. However, the system may not go down at orders (1) to (3) on the kernel side, they are not counted as the initial definition.
 - (1) Initial definition of interrupt handlers in the interrupt/CPU exception handler page
 - (2) Initial definition of CPU exception handlers in the interrupt/CPU exception handler page
 - (3) Initial definition of CPU exception handlers for trap in the trap exception handler page
 - (4) Initial definition of tasks and task exception processing routines in the task page
 - (5) Initial definition of semaphores in the semaphore page
 - (6) Initial definition of event flags in the event flag page
 - (7) Initial definition of data queues in the data queue page
 - (8) Initial definition of mailboxes in the mailbox page
 - (9) Initial definition of mutexes in the mutex page
 - (10) Initial definition of message buffers in the message buffer page
 - (11) Initial definition of fixed-size memory pools in the fixed-size memory pool page
 - (12) Initial definition of variable-size memory pools in the variable-size memory pool page
 - (13) Initial definition of cyclic handlers in the cyclic handler page
 - (14) Initial definition of alarm handlers in the alarm handler page
 - (15) Initial definition of overrun handlers in the overrun handler page
 - (16) Initial definition of extended service calls in the extended service call page

B.3 Error during Compiling

B.3.1 Error when Files are for a Different HI7000/4 Series

If `kernel_cfg.c` and `kernel_def.c` are compiled using the file created by the configurator in a different HI7000/4 series environment, the following message is displayed during compiling. The underlined part shows the target OS for the file created by the configurator.

Unmatch HIOS (This file is designed for HI7750/4.)

B.3.2 Errors to Do with the Optimized Timer Driver (HI7700/4)

The definition file `kernel_def_opttmr_set.h` for the optimized timer driver and setting in the Time management function page in the configurator are checked for the errors shown in table B.3 when `kernel_def.c` and `kernel_cfg.c` are compiled.

Table B.3 Errors of the Optimized Timer Driver

Error Message	Meaning
#error directive: "Illegal CFG_TIMUSE"	CFG_TIMUSE is not checked in the configurator. Check CFG_TIMUSE.
#error directive: "Illegal hi_longticrate"	Illegal hi_longticrate setting. Specify hi_longticrate as an integer constant in the 2 to 0xff range.
#error directive: "Illegal hi_pclock"	Illegal hi_pclock setting. Specify an integer constant other than 0 for hi_pclock.
#error directive: "Illegal CFG_TIMINTNO"	Illegal CFG_TIMINTNO setting. Specify 0x400.
#error directive: "Illegal CFG_TIMINTLVL"	Illegal CFG_TIMINTLVL setting. Specify the value same as kernel interrupt mask level (CFG_KNLMSKLVL). Note, this error is not detected when kernel_def.c is compiled.

B.3.3 Errors to Do with the DSP-Standby Control Function (HI7700/4)

The definition file kernel_def_dspstby_set.h for the DSP-standby control function is checked for the errors shown in table B.4 when kernel_def.c and kernel_cfg.c are compiled.

Table B.4 Error of the DSP-Standby Control Function

Error Message	Meaning
#error directive: "Illegal hi_cop_stby_adr"	Illegal hi_cop_stby_adr setting. Specify hi_cop_stby_adr as a non-zero integer constant.
#error directive: "Illegal hi_cop_stby_bit"	Illegal hi_cop_stby_bit setting. Specify hi_cop_stby_bit as an integer constant in the 1 to 0xff range when using SH3-DSP. Specify hi_cop_stby_bit as an integer constant in the 1 to 0xffff range when using SH4AL-DSP.

Appendix C Calculation of Work Area Size

C.1 Work Areas

To facilitate memory allocation, a section is assigned for each work area as listed in table C.1. Allocate these sections to suitable addresses at linkage.

Table C.1 Work Areas

Work Area	Section Name	File Defining Sections
Kernel work area	B_hiwrk	kernel_cfg.c
CPU vector table (HI7000/4 only)	B_hivct	
Static stack area	B_histstk	
Dynamic stack area	B_hidystk	
Interrupt handler and time event handler stack area	B_hiirqstk	
Memory pool area	B_himpl	
DX target trace buffer area	B_hitrcbuf	
Memory pool management table *	B_hicfg	
DX emulator trace (tool trace) area	B_hitrceml	
Memory pool management table *	B_hidef	kernel_def.c
Work area used by application	Determined by user	Determined by user

Note: * When a fixed-size memory pool is created while CFG_MPFMANAGE is selected through the configurator or when a variable-size memory pool with the VTA_UNFRAGMENT attribute is created while CFG_NEWMPL is selected through the configurator.

For the size of each section, refer to the compile listing.

Kernel Work Area (Section B_hiwrk, B_hidef, B_hicfg): Used for kernel operation; contains the task control block (TCB), message buffer area, and kernel stack area. The size of the kernel work area is determined according to object maximum IDs such as CFG_MAXTSKID, or CFG_DTQSZ, and CFG_MBFSZ.

CPU Vector Area (Section B_hivct): The CPU vector table is created in this section when CFG_VCTRAM has been selected.

Static Stack Area (Section B_histstk): Static stack area statically defined and allocated by the configurator.

Dynamic Stack Area (Section B_hidystk): Task stack area dynamically allocated when a task is created. The size of the dynamic stack area is determined according to CFG_TSKSTKSZ.

Interrupt Handler and Time Event Handler Stack Area (Section B_hirqstk): Area used by interrupt handlers and time event handlers. The size of the interrupt handler and time event handler stack area is determined according to CFG_IRQSTKSZ and CFG_TMRSTKSZ, respectively.

Memory Pool Area (Section B_himpl): Area for variable-size and fixed-size memory pools. The size of the memory pool area is determined according to CFG_MPLSZ and CFG_MPFSZ.

DX Trace Buffer Area (Section B_hitrbuf): This area is allocated when the target trace is set to CFG_TRCTYPE. The size is fixed to CFG_TRCUBFSZ bytes.

DX Emulator Trace (Tool Trace) Area (Section B_hitrceml): This area is allocated when emulator trace (tool trace) is specified through CFG_TRCTYPE. The size is fixed to 14 bytes.

Work Area Used by Application: Area for variables used by applications.

C.2 Stack Types

Each task or handler requires its own contiguous stack area. If a stack overflows, the system will operate incorrectly. Therefore, the user must determine the stack size required for each task or handler execution and allocate enough area for each task or handler by referring to the following description.

Task Stack: An independent stack used by each task ID. The kernel switches task stacks at task scheduling. A task exception processing routine also uses the stack used by the same task. Task stacks are classified into static stacks and dynamic stacks. In addition, the stack area that is allocated by application can be used.

The task stack is switched by the kernel. Accordingly, the stack must not be switched by the task.

Interrupt Handler Stack: When a normal interrupt occurs, the stack is switched to the one dedicated to the interrupt handler by the kernel. Accordingly, the stack must not be switched by the interrupt handler. When a direct interrupt of the HI7000/4 occurs, the stack must be allocated and switched by the interrupt handler. Unless it is switched, the interrupt handler uses the stack of the task that was executed before the interrupt occurred. Therefore, the task stack may overflow.

When the HI7000/4 is used, the NMI must be defined as the direct interrupt handler. However, the NMI has the possibility of re-entry, so stack switching must not be performed by the NMI interrupt handler. Stacks for tasks and handlers must be reserved considering the size used by the NMI interrupt handler since the stack before the NMI occurrence is used by the NMI interrupt handler.

The time event handler uses the interrupt handler stack. The stack must not be switched by the time event handler.

Kernel Stack: Stack used by the kernel. It is also used by the initialization routine. The stack must not be switched in the initialization routine.

Stack Used before Kernel Initiation: The stacks used by programs executed before kernel initiation, such as the CPU initialization routine, are not managed by the kernel. Therefore, the user can use the desired area for the stack. In the HI7000/4, the stack pointer at power-on reset must be set in the reset vector. In the HI7700/4 and HI7750/4, it must be defined at the beginning of the CPU initialization routine.

For a microcomputer having built-in RAM, allocate the stack at reset to the built-in RAM. For a microcomputer without built-in RAM, the stack (the user system RAM) may not be accessed during reset depending on the bus state controller (BSC) status immediately after reset. In this case, do not run programs that use stacks and do not generate any interrupts or exceptions until the memory becomes accessible by changing the BSC settings. This is because register data is stored in the stack when interrupts or exceptions occur.

C.3 Stack Size Calculation Procedure

Use the stack size calculation procedure shown in figure C.1 to define the appropriate sizes in the corresponding definition parts.

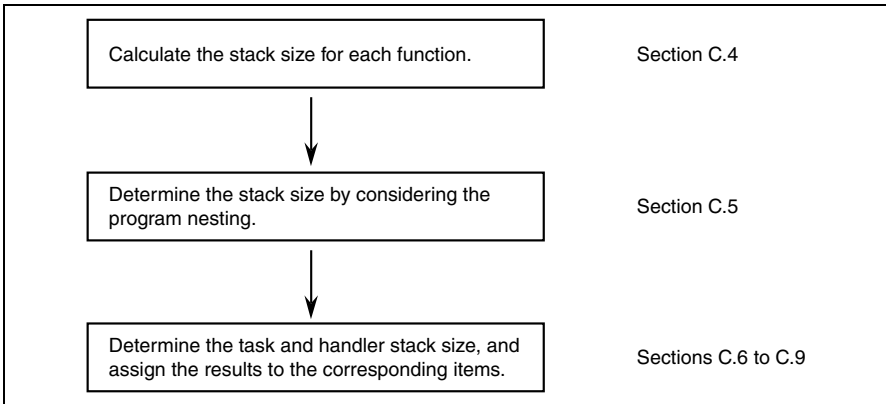

Figure C.1 Stack Size Calculation Procedure

C.4 Calculation of Stack Size for Each Function

C Language Function: When a C language function is initiated, a stack frame is allocated in the stack area. The stack frame is used as a local variable area for the function or as a parameter area for a function call. The stack frame size can be determined from the frame size in the object listing output by the compiler.

An example is shown below.

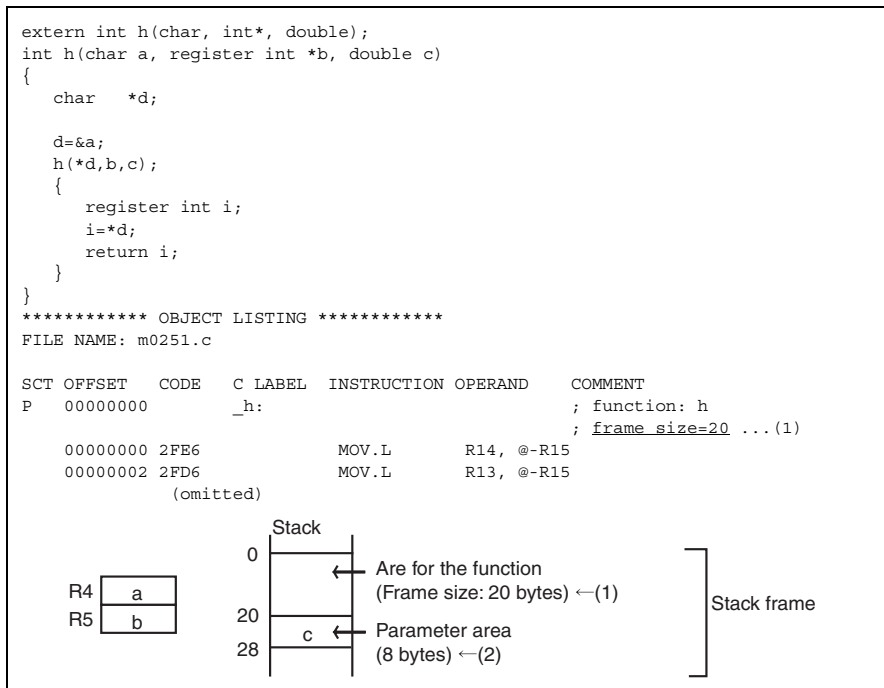

Figure C.2 Compile List and Stack Size

The stack area size used by the function is obtained by adding (1) and (2) shown above, 28 bytes.

For details on parameters allocated to the parameter area on the stack, refer to the SuperH™ RISC engine C/C++ Compiler User's Manual.

Assembly Language Function: To calculate the stack size, examine the stack push and pop (in predecrement and postincrement register indirect addressing mode) instructions used in the program. When parameters are pushed onto the stack at function call, the area size for the parameters must be added to the stack size.

C.5 Stack Size Considering Programming Nesting

A stack size considering programming nesting is calculated with the following program start functions as a base point.

- Tasks
- Interrupt handlers
- Time event handlers
- Initialization routine

Programming nesting includes all functions that are called from these start functions and the following program calls.

- Extended service call routine
- Task exception processing routine
- CPU exception handlers (containing TRAPA instruction exception handlers)

Calculate the total value of the stack sizes used by each function and determined according to appendix C.4, Calculation of Stack Size for Each Function above for each nesting case. When the task exception processing routine or CPU exception handlers (containing TRAPA instruction exception handlers) is nested, add the value shown in table C.2 for each nesting.

Table C.2 Additional Stack Size of the Call Routine and the Handlers

Item	Additional Size (Byte)		
	HI7000/4	HI7700/4	HI7750/4
Task exception processing routine	172	172 *2	180
TA_COP0 attribute included *1	56	56	—
TA_COP1 attribute included	72	—	64
TA_COP2 attribute included	—	—	64
CPU exception handlers (containing TRAPA instruction exception handlers)	44	44	48

Note: 1 In the HI7700/4, TA_COP0 attribute can be set or cleared by vchg_cop service call. This additional size is necessary when TA_COP0 attribute is set by vchg_cop.
 2 With the optimization timer driver or the DSP standby control function, it becomes 168.

Appendix C Calculation of Work Area Size

An example of calculation is shown below for the HI7700/4 where the stack size considering programming nesting is added. The program nesting shown in figure C.3 is used as an example.

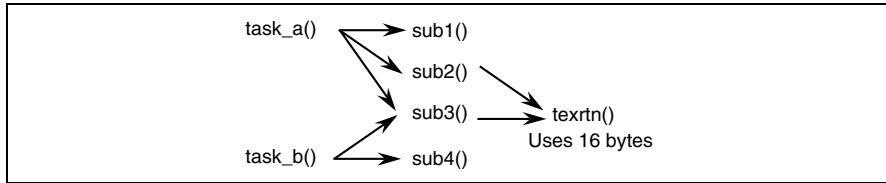

Figure C.3 Programming Nesting

The stack size of each function is assumed as follows:

Table C.3 Stack Size of Each Function

Function	Size (Byte)	Note
task_a	56	Start function of task A, No TA_COP0 attribute included
task_b	40	Start function of task B, No TA_COP0 attribute included
sub1	88	task_a subroutine
sub2	8	task_a subroutine
sub3	24	Common subroutine
sub4	12	task_b subroutine
texrtn	172 + 16 = 188	Start function of task exception processing routine, No TA_COP0 attribute included, CFG_NEWMPL is not selected

The stack sizes of tasks A and B, considering the calling path, are shown in table C.4.

Table C.4 Task Size Considering Calling Path

Task	Calling Path	Task Size (Byte)
Task A	task_a<56 bytes> → sub1 <88 bytes>	144
	task_a<56 bytes> → sub2 <8 bytes> → texrtn <160>	224
	task_a<56 bytes> → sub3 <24 bytes> → texrtn <160>	240 (maximum)
Task B	task_a<40 bytes> → sub3 <24 bytes> → texrtn <160>	224 (maximum)
	task_a<56 bytes> → sub4 <12 bytes>	68

C.6 Task Stacks

C.6.1 Stack Size Used by Each Task

Each task stack size can be determined by substituting the size obtained according to appendix C.5 above into table C.5.

For tasks that use the dynamic stack, specify the value calculated using table C.5 as a stack size when a task is created (by `cre_tsk` and `acre_tsk` service calls and the configurator).

For tasks that use a static stack, allocate the stack size calculated using table C.5 by the configurator.

Table C.5 Task Stack Size

Item	Stack Size (Byte)		
	HI7000/4	HI7700/4	HI7750/4
Size obtained in C.4 and C.5			
Mandatory	140	184 * ⁴	196
TA_COP0 attribute included * ³	56	56	—
TA_COP1 attribute included	72	—	64
TA_COP2 attribute included	—	—	64
Static stacks	8	8	8
CFG_TRACE is selected	24	24	24
CFG_NEWMPL is selected	28	28	28
Addition considering nested interrupts	* ¹	—	—
The added value when the NMI is used	* ²	—	—
Total			

- Note:
1. (1) When NOBANK, NOTUSE, or SELECT has been selected for CFG_REGBANK:
 - (1.1) When CFG_DIRECT has been selected
 $12 \times \text{CFG_UPPINTNST} + 20 \times \text{CFG_LOWINTNST}$
 - (1.2) When CFG_DIRECT has not been selected
 $12 \times \text{CFG_UPPINTNST} + \underline{24 \times \text{CFG_LOWINTNST}} + 20$
 However, when CFG_LOWINTNST is 0, assume the underlined part to be 0.
 - (2) When ALL has been selected for CFG_REGBANK
 $8 \times \text{CFG_UPPINTNST} + 16 \times \text{CFG_LOWINTNST}$
 If you are using UBC interrupts, however, the following values must also be added.
 - UBC interrupts used as direct interrupts: 4 bytes
 - UBC interrupts used as normal interrupts: 28 bytes
 2. ((Size of the stack area used by the NMI interrupt handler calculated as shown in appendixes C.4 and C.5) + 8) × (NMI nest count)
 When there is no nesting, the NMI nest count is 1.
 3. In the HI7700/4, TA_COP0 attribute can be set or cleared by vchg_cop service call. This additional size is necessary when TA_COP0 attribute is set by vchg_cop.
 4. With the optimization timer driver or the DSP standby control function, it becomes 208.

C.6.2 Stack Area Acquisition

The dynamic stack area can be automatically allocated by specifying a size in CFG_TSKSTKSZ by the configurator. For CFG_TSKSTKSZ, use the value of the following equation or a larger size.

$$\text{CFG_TSKSTKSZ} = \sum (\text{Stack use size of the task which uses dynamic stack} + 16) + 28$$

C.7 Interrupt Handler Stacks

C.7.1 Stack Size Used by an Interrupt Handler

The interrupt-handler stack size can be determined by substituting the size obtained from appendix C.5 above into table C.6. The stack size for the NMI interrupt handler must be calculated by using the item no. 1 in table C.6. This value is used in the calculation in appendixes C.6 to C.9.

Table C.6 Interrupt Handler Stack Size

Item	Stack Size (Byte)			
	HI7000/4		HI7700/4	HI7750/4
	Direct Interrupt Handler	Normal Interrupt Handler		
Size obtained in C.4 and C.5				
Calls service call	168	168	168 ^{*3}	172
CFG_TRACE is selected	24	24	24	24
CFG_NEWMPL is selected	28	28	28	28
Addition considering nested interrupts	^{*1}	—	—	—
Added value when the NMI is used	^{*2}	—	—	—
Total				

- Note:
1. **uppintnst:** The nest count of direct interrupts that are higher than CFG_KNLMSKLVL and the interrupt level

lowintnst: The nest count of interrupts that are lower than or equal to CFG_KNLMSKLVL and higher than the interrupt level

(1) When NOBANK, NOTUSE, or SELECT has been selected for CFG_REGBANK:

(1.1) When CFG_DIRECT has been selected

$$12 \times \text{uppintnst} + 20 \times \text{lowintnst}$$

(1.2) When CFG_DIRECT has not been selected

$$12 \times \text{uppintnst} + \underline{24} \times \text{lowintnst} + \underline{20}$$

However, when lowintnst is 0, assume the underlined part to be 0.

(2) When ALL has been selected for CFG_REGBANK

$$8 \times \text{uppintnst} + 16 \times \text{lowintnst}$$

If you are using UBC interrupts, however, the following values must also be added.

 - UBC interrupts used as direct interrupts: 4 bytes
 - UBC interrupts used as normal interrupts: 28 bytes
 2. ((Size of the stack area used by the NMI interrupt handler calculated as shown in appendixes C.4 and C.5) + 8) × (NMI nest count)

When there is no nesting, the NMI nest count is 1.
 3. With the optimization timer driver or the DSP standby control function, it becomes 164.

C.7.2 Stack Area Allocation

Direct Interrupt Handlers (HI7000/4):

Since handlers of the same level are not activated concurrently, allocate the stack area of the handler that uses the largest stack area from among the same interrupt-level interrupt handlers as the handler stack area of the corresponding interrupt level. Then switch to the stack at the beginning of the interrupt handler. Refer to section 4.8, Interrupt Handlers when switching stacks by interrupt handler. In this case, separate stacks can be used instead of sharing a stack within the same interrupt-level handlers. Note, however, that a stack dedicated to the NMI interrupt handler cannot be used since NMI has the possibility of re-entry. The stack size to be used by the NMI interrupt must be added in appendixes C.6 to C.9 because the NMI interrupt handler uses the stack at the point of the NMI occurrence.

Normal Interrupt Handlers:

All interrupt handlers use the same interrupt handler stack. The interrupt handler stack area can be automatically allocated by specifying a size in CFG_IRQSTKSZ by the configurator. For CFG_IRQSTKSZ, use the value of the following equation or a larger size.

- HI7000/4

(1) When CFG_DIRECT has been selected:

Since there are no normal interrupt handlers, an interrupt handler stack area is not allocated.

(2) When CFG_DIRECT has not been selected:

(a) When NOBANK, NOTUSE, or SELECT has been selected for CFG_REGBANK:

CFG_IRQSTKSZ =

$$\begin{aligned} & \sum (\text{Size of the largest stack area used by the handler at the interrupt level}) + 4 \\ & + 12 \times \text{CFG_UPPINTNST} + \underline{24 \times (\text{CFG_LOWINTNST} - 1) + 20} \\ & + ((\text{Size of the stack area used by the NMI interrupt handler calculated as shown in} \\ & \text{appendixes C.4 and C.5}) + 8) \times (\text{NMI nest count}) \end{aligned}$$

However, when CFG_LOWINTNST <= 1, assume the underlined part to be 0.

(b) When ALL has been selected for CFG_REGBANK:

CFG_IRQSTKSZ =

$$\begin{aligned} & \sum (\text{Size of the largest stack area used by the handler at the interrupt level}) + 4 \\ & + 8 \times \text{CFG_UPPINTNST} + \underline{16 \times (\text{CFG_LOWINTNST} - 1) + 20} \\ & + ((\text{Size of the stack area used by the NMI interrupt handler calculated as shown in} \\ & \text{appendixes C.4 and C.5}) + 8) \times (\text{NMI nest count}) \end{aligned}$$

However, when CFG_LOWINTNST <= 1, assume the underlined part to be 0.

If you are using UBC interrupts, however, the following values must also be added.

— UBC interrupts used as direct interrupts: 4 bytes

— UBC interrupts used as normal interrupts: 28 bytes

- HI7700/4

$$\text{CFG_IRQSTKSZ} = \sum (\text{Size of the largest stack area used by the handler at the interrupt level}) + 4 + 44 \times ((\text{Number of interrupt levels in the system, except NMI}) - 1) + ((\text{Size of the stack area used by the NMI interrupt handler calculated as shown in appendixes C.4 and C.5}) + 44) \times (\text{NMI nest count})$$
- HI7750/4

$$\text{CFG_IRQSTKSZ} = \sum (\text{Size of the largest stack area used by the handler at the interrupt level}) + 4 + 48 \times ((\text{Number of interrupt levels in the system, except NMI}) - 1) + ((\text{Size of the stack area used by the NMI interrupt handler calculated as shown in appendixes C.4 and C.5}) + 48) \times (\text{NMI nest count})$$

When there is no nesting, the NMI nest count is 1.

C.8 Stack Size Used by a Time Event Handler and Timer Interrupt Routine

The size of each time event handler stack and timer interrupt routine (`_kernel_tmrint()`) stack can be determined from appendixes C.4 and C.5.

The size determined by substituting the maximum size of all time event handlers and timer interrupt routine into Table C.7 must be assigned to `CFG_TMRSTKSZ`.

When `CFG_ACTION` is selected, calculate under the following conditions.

- Size obtained in C.4 and C.5: 32
- Calls service calls: Yes

When no time event handler is used and `CFG_ACTION` is not selected, calculate under the following conditions.

- Size obtained in C.4 and C.5: 0
- Calls service calls: No

Table C.7 Time Event Handler and Timer Interrupt Routine Stack Size

Item	Stack Size (Byte)		
	HI7000/4	HI7700/4	HI7750/4
Size obtained in C.4 and C.5			
Mandatory	(1) CFG_REGBANK is not selected: 144 (2) CFG_REGBANK is selected: 68	140 ^{*3}	144
CFG_NEWMPL is selected	28	28	28
Calls service call	140	140	144
CFG_TRACE is selected	24	—	—
Addition considering nested interrupts	^{*1}	—	—
Addition when the NMI is used	^{*2}	—	—
Total			

- Note:
1. **uppintnst:** The nest count of direct interrupts that are higher than CFG_KNLMSKLVL and CFG_TIMINTLV
 - lowintnst:** The nest count of interrupts that are lower than or equal to CFG_KNLMSKLVL and higher than CFG_TIMINTLV
- (1) When NOBANK, NOTUSE, or SELECT has been selected for CFG_REGBANK:
- (1.1) When CFG_DIRECT has been selected
 $12 \times \text{uppintnst} + 20 \times \text{lowintnst}$
 - (1.2) When CFG_DIRECT has not been selected
 $12 \times \text{uppintnst} + \underline{24 \times \text{lowintnst} + 20}$
- However, when lowintnst is 0, assume the underlined part to be 0.
- (2) When ALL has been selected for CFG_REGBANK
 $8 \times \text{uppintnst} + 16 \times \text{lowintnst}$
- If you are using UBC interrupts, however, the following values must also be added.
- UBC interrupts used as direct interrupts: 4 bytes
 - UBC interrupts used as normal interrupts: 28 bytes
2. ((Size of the stack area used by the NMI interrupt handler calculated as shown in appendixes C.4 and C.5) + 8) × (NMI nest count)
 When there is no nesting, the NMI nest count is 1.
 - 3 With the optimization timer driver or the DSP standby control function, it becomes 164.

C.9 Initialization Routine Stacks

The size of each initialization routine stack can be determined by substituting the size obtained from appendix C.5 above into table C.8. When each initialization routine is defined by the configurator, the size obtained in this section must be used.

The initialization routine is executed in serial, the maximum size of each initialization routine stack is allocated.

Table C.8 Initialization Routine Stack Size

Item	Stack Size (Byte)		
	HI7000/4	HI7700/4	HI7750/4
Size obtained in C.4 and C.5			
Calls service call	140	140 *2	144
CFG_TRACE is selected	24	24	24
CFG_NEWMPL is selected	28	28	28
Addition when the NMI is used	*1	—	—
Total			

- Notes: 1. $(\text{Size of the stack area used by the NMI interrupt handler calculated as shown in appendixes C.4 and C.5} + 8) \times (\text{NMI nest count})$
When there is no nesting, the NMI nest count is 1.
2. With the optimization timer driver or the DSP standby control function, it becomes 164.

C.10 Timer Initialization Routine Stack

The maximum stack size to be used by timer initialization routine (`_kernel_tmtrini()`) is determined as follows.

- HI7000/4: 252 bytes
- HI7700/4: 208 bytes
- HI7750/4: 204 bytes

When the size calculated by table C.9 exceeds the above size, allocate a new stack area with the calculated size and switch to that stack.

Table C.9 Timer Initialization Routine Stack Size

Item	Stack Size (Byte)		
	HI7000/4	HI7700/4	HI7750/4
Size obtained in C.4 and C.5			
Calls service call	140	140 * ²	144
CFG_TRACE is selected	24	24	24
CFG_NEWMPL is selected	28	28	28
Addition when the NMI is used	* ¹	—	—
Total			

- Notes:
1. $(\text{Size of the stack area used by the NMI interrupt handler calculated as shown in appendixes C.4 and C.5}) + 8) \times (\text{NMI nest count})$
When there is no nesting, the NMI nest count is 1.
 2. With the optimization timer driver or the DSP standby control function, this value becomes 164.

Appendix D Timer Driver

D.1 Overview

A timer driver must be required for the time-management functions of the kernel (CFG_TIMUSE is selected) to be usable. Timer drivers are of two types: standard timer driver and optimized timer driver.

- **Standard Timer Driver**
User must create the standard timer driver, and link to kernel. The HI7000/4 series provide samples for some microcomputer.
- **Optimized Timer Driver**
The optimized timer driver is supported by only HI7700/4. The optimization timer driver fewer interrupts than the standard timer driver. The optimized timer driver is built into the kernel and cannot be created by the user.

For how to use the optimized timer driver, refer to Appendix E, Optimized Timer Driver (HI7700/4). The following sections explain the specifications of the standard timer driver.

D.2 Standard Timer Driver

The standard timer driver is composed of the timer initialization routine and the timer interruption routine. The timer interruption processing routine is called from timer interruption handler `_kernel_isig_tim()` of the kernel, and clears the interruption factor. And, the timer initialization routine is executed as an initialization routine.

D.2.1 Installing the Time Management Function

To use the time management function of the kernel, the following operations are required:

1. Set the time management function page by the configurator

Here the following kernel function constants are defined:

- TIC_NUME: Numerator of time tick cycle (CFG_TICNUME)
- TIC_DENO: Denominator of time tick cycle (CFG_TICDENO)
- TIM_LVL: Timer interrupt level (CFG_TIMINTLVL)

The cycle time when the time tick is provided is TIC_NUME/TIC_DENO (ms). Based on this cycle time, the precision of the time parameter specified in the service call is determined. For example, when `tslp_tsk(10)` is executed, timeout time is 12 to 15 ms if $TIC_NUME = 3$ and $TIC_DENO = 1$; timeout time is 10 to 10.5 ms if $TIC_NUME = 1$ and $TIC_DENO = 2$. Note that at least one of TIC_NUME and TIC_DENO must be specified as 1.

In addition, if TIC_DENO is specified as a value greater than 1, the maximum value that can be specified to TMO-, RELTIM-, and OVRTIM-type parameters is limited to the available maximum value/ TIC_DENO .

The following operations are automatically performed by setting the time management function page by the configurator.

- `_kernel_tmrini()` is defined as the kernel initialization routine.
- `isig_tim` processing module of the kernel is defined as the timer interrupt handler.

2. Create a timer driver

Here, the following two C language functions are created. These function names are fixed.

- Timer initialization routine: `_kernel_tmrini()`
- Timer interrupt routine: `_kernel_tmrint()`

The timer initialization routine is created as an initialization routine. For details, refer to section 4.10, Time Event Handlers and Initialization Routine.

In the timer initialization routine, initialize the timer counter registers according to the `TIC_NUME` and `TIC_DENO`, as defined in `kernel_macro.h`, and specify timer interrupt level according to `TIM_LVL`, as defined in `kernel_macro.h`.

When a timer interrupt occurs, the `isig_tim` processing module of the kernel is initiated as an interrupt handler. The `isig_tim` processing module then calls the timer interrupt routine `_kernel_tmrint()`. In the timer interrupt routine `_kernel_tmrint()`, clear the interrupt factor flag.

The timer interrupt routine can be defined as a normal C language function, as shown in figure D.1. The timer interrupt processing routine operates as a part of the interrupt handler.

```
#include "kernel.h"
void _kernel_tmrint(void)          ←Function name is fixed.
{
    /* Routine processing */
}
```

Figure D.1 Example of a C Language Timer Interrupt Routine

Rules on timer interrupt routine register specifications are the same as normal interrupt handlers. For details, refer to section 4.8.1, Normal Interrupt Handler.

To use the DSP in the timer initialization routine and the timer interrupt routine, refer to section 4.13, Using the DSP in Programs (for HI7000/4 and HI7700/4 only).

To use the FPU in the timer initialization routine and the timer interrupt routine, refer to appendix G.2, Non-Task Context (Normal Interrupt Handler, Direct Interrupt Handler, CPU Exception Handler, Time Event Handler, Initialization Routine).

3. Link the timer driver

The timer driver must be linked to the kernel.

D.2.2 Sample Timer Driver

The sample timer driver consists of the following header files and source files:

1. Device header file (file name: *nnnn_tmrdrv.h*)
This file defines register I/O addresses and initial values, and timer device information. These values do not need to be modified.
2. Header file (file name: *nnnn_tmrdef.h*)
This file defines information that determines timer driver operations such as clock frequency.
3. Source program file (file name: *nnnn_tmrdrv.c*)
 - Timer initialization routine (function: void `_kernel_tmrini(void)`)
 - Timer interrupt routine (function: void `_kernel_tmrint(void)`)

The timer interrupt period (T) is calculated by follow expression.

$$T [\text{sec}] = \{ (1 / \text{PCLOCK}) \times \text{DIV} \} \times N$$

- PCLOCK[Hz]: Frequency which is supplied to the timer module
- DIV: Divided ratio by setting of the timer module register
- N: The number of timer clock counts which expires the period (T)

In general, the following expressions consist to count the timer module $n + 1$ when n is set to the counter register of the timer module. For the sample timer drivers, each sign in the above expression is made to correspond as follows.

$$n = N - 1$$

The sample timer drivers, which are provided by the HI7000/4 series, calculate n according to the above calculation method, and set to register of the timer module.

- T: CFG_TICNUME/CFG_TICDENO [ms]
- PCLOCK: “PCLOCK” which is defined in the *nnnn_tmrdef.h*. [Hz]
- DIV: In the HI7000/4, “DIV” which is defined in the *nnnn_tmrdrv.c*.
In the HI7700/4 and HI7750/4, the DIV is selected automatically in order to “PCLOCK”.
- n: The above expression is defined in “COUNTER” in the *nnnn_tmrdrv.c*.

Note that, when the calculated value as COUNTER is larger than the counter register size, the period is illegal. Do confirm this.

And, when the calculated value as COUNTER is not integer, the value is rolled to integer. In this case, the period at run-time is shorter than expected period (CFG_TICNUME/CFG_TICDENO).

Table D.1 shows sample timer driver files provided by each product at this manual creation time and the clock source of the timer modules assumed by the sample timer driver. For more detail, refer to the contents of the header file.

Table D.1 Sample Timer Driver Files and Clock Sources

Product	nnnn	Target Microcomputers and Internal Timer Modules		Assumed Timer Module Clock Source
HI7000/4	7011	SH7011, SH7018	CMT	System clock (ϕ) = 20 MHz
V.2.02	703x	SH7020, SH7021, SH7032, SH7034	ITU	System clock (ϕ) = 20 MHz
	704x	SH7040, SH7041, SH7042, SH7043, SH7044, SH7045, SH7014, SH7016, SH7017	CMT	System clock (ϕ) = 28 MHz
	7046	SH7046, SH7047, SH7048, SH7049, SH7144, SH7145, SH7148	CMT	System clock (ϕ) = 40 MHz
	7050	SH7050, SH7051	CMT	System clock (ϕ) = 20 MHz
	7052	SH7052, SH7053, SH7054	CMT	Peripheral clock (ϕ) = 20 MHz
	7065	SH7065	CMT	Peripheral clock ($P\phi$) = 30 MHz
	7604	SH7604	FRT	System clock (ϕ) = 28.7 MHz
	7615	SH7615, SH7616	FRT	Peripheral clock ($P\phi$) = 30 MHz
	7618	SH7618	CMT	Peripheral clock ($P\phi$) = 12.5 MHz
	72060	SH72060	CMT	Peripheral clock ($P\phi$) = 24 MHz
HI7700/4	7707	SH7707	TMU	Peripheral clock ($P\phi$) = 30 MHz
V.2.02	7708	SH7708, SH7708R, SH7708S	TMU	Peripheral clock ($P\phi$) = 15 MHz
	7709	SH7709	TMU	Peripheral clock ($P\phi$) = 30 MHz
	7709a	SH7709A, SH7709S, SH7706	TMU	Peripheral clock ($P\phi$) = 33.34 MHz
	7729	SH7729, SH7729R, SH7727	TMU	Peripheral clock ($P\phi$) = 33.34 MHz
	7290	SH7290, SH7294, SH7300	TMU	Peripheral clock ($P\phi$) = 19.8 MHz
	7641	SH7641	CMT	Peripheral clock ($P\phi$) = 25 MHz
	7318	SH7318	TMU	Peripheral clock ($P\phi$) = 27 MHz
	7343	SH7343	TMU	Peripheral clock ($P\phi$) = 27 MHz
HI7750/4	7750	SH7750, SH7750S, SH7750R	TMU	Peripheral clock ($P\phi$) = 50 MHz
V.2.02	7751	SH7751, SH7751R	TMU	Peripheral clock ($P\phi$) = 41.6 MHz
	7760	SH7760	TMU	Peripheral clock ($P\phi$) = 33.34 MHz
	7770	SH7770	TMU	Peripheral clock ($P\phi$) = 50 MHz
	7785	SH7785	TMU	Peripheral clock ($P\phi$) = 50 MHz

The operation conditions of the sample timer driver are defined in the header files. The header files can be modified as required. Note, however, that to change the timer interrupt cycle time, the time tick cycle (CFG_TINUME and CFG_TICDENO) must be changed by the configurator not by changing the header file.

Appendix E Optimized Timer Driver (HI7700/4)

E.1 Overview

The standard timer driver generates timer interrupts in the same cycle as the time precision for service calls (CFG_TICNUME/CFG_TICDENO [ms]). When the optimized timer driver is used, the frequency of interrupts can be reduced while the time precision for service calls is maintained. This is expected to have the following effects:

- The frequency of timer-interrupt generation during sleep mode is reduced; this leads to improved power consumption.
- Reducing the frequency of timer interrupts lowers the percentage of CPU time taken up by timer-interrupt processing and improves the throughput of the system. Alternatively, the CPU may be placed in the low power-consumption mode for a greater part of the time.

Unlike the standard timer driver, the optimized timer driver is built into the kernel. The user cannot create an optimized timer driver.

In addition, this function does not require the modification of existing application programs.

E.2 Operation

Figure E.1 shows examples of operation where the standard timer driver and optimized timer driver are used to provide time precision of 1 ms (CFG_TICNUME/CFG_TICDENO).

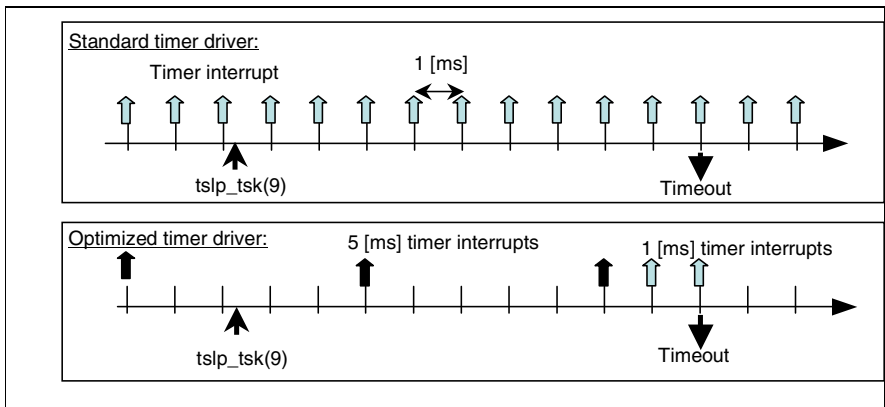

Figure E.1 Example of Operation

Two TMU timer channels, one with a 1 ms and the other with a 5 ms period, are used in operating the optimized timer driver as shown in figure E.1; the respective timing cycles are called the high-precision and low-precision cycle. The high-precision cycle is the result, in ms, of the division of values specified by the configurator, i.e., CFG_TICNUME/CFG_TICDENO.

Appendix E Optimized Timer Driver (HI7700/4)

The period of the low-precision cycle is an integer multiple of this period and is set by the user statically.

When the optimized timer driver is in use, the kernel investigates the following situations at the right time.

- Waiting tasks by service calls with timeout (txxx_yyy)
- Waiting tasks by dly_tsk service call
- Cyclic handlers
- Alarm handlers

The kernel uses the results to determine whether or not interrupts from the high-precision cycle are needed, and accordingly enables or disables the corresponding interrupt.

Interrupts from the low-precision cycle are always enabled.

Although figure E.1 does not show this, a further TMU channel is used in monitoring for the overrun handler. This timer interrupt is only generated when a task has used the upper limit on the allowed processor time.

Figure E.2 shows two effects of using the optimized timer driver. This function reduces the frequency of timer interrupts, leading to the following advantages over the standard timer driver.

- Quicker transitions to sleep mode (lower amounts of CPU time consumed in timer-interrupt processing)
- Less frequent cancellation of sleep mode for the processing of timer interrupts

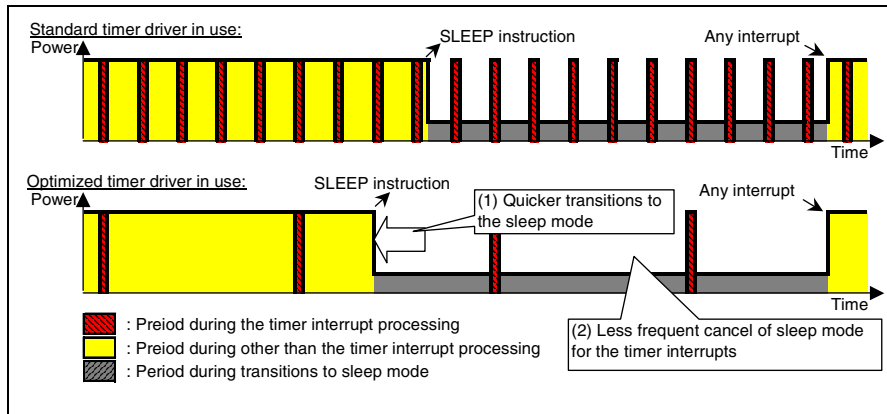

Figure E.2 Schematic Illustration of the Optimized Timer Driver's Effects

E.3 Applicable MCUs

The optimized timer driver uses TMU with build-in MCU. However, the optimization timer driver might not be able to be used even in case of MCU with built-in TMU. At the time of writing, the optimized timer driver can only be run with the following MCUs:

SH7630, SH7290, SH7294, SH7300, SH7660, SH7318, SH7343

For the latest information, refer to the release notes on individual products.

E.4 Hardware Initialization

The following processing is carried out to initialize the optimized timer driver when the kernel is started up:

- (1) Cancels the module standby state of TMU.
- (2) Initializes channels 0, 1, and 2.
- (3) Sets the interrupt levels of channels 0, 1, and 2 for the interrupt controller.

However, when the `def_ovr` service call has not been selected in the configurator, settings for channel 2 in the above (2) and (3) are not made.

Note that the optimized timer driver does not place the TMU in the module-standby state.

E.5 Differences with the Standard Timer Driver

Table E.1 shows the differences between the standard and optimized timer drivers.

Table E.1 Differences between the Standard and Optimized timer Drivers

	Standard Timer Driver	Optimized Timer Driver
Time precision of service calls	CFG_TICNUME/ CFG_TICDENO (ms)	As at left (however, the time precision of the overrun handler is always 1 ms).
Required hardware timer	One channel of any timer (channel 0 of the TMU is used with the sample standard timer driver)	Channels 0, 1, and 2 of the TMU. However, when <code>def_ovr</code> is not selected, channel 2 is unused.
Timer-interrupt level	A user-defined value between 1 and the kernel's interrupt-mask level (CFG_KNLMSKLVL) is set in CFG_TIMINTLVL.	Limited to the kernel interrupt mask level.
Driver creation by the user	Possible	Not possible

E.6 Ways to Include Optimized Timer Driver

E.6.1 Overview

This section gives information that is supplementary to the standard configuration procedure. For details, see section 5, Configuration.

Table E.2 shows the procedures which must be followed to include a timer driver.

Table E.2 Including a Timer Driver

Item		No Timer Driver	Standard Timer Driver	Optimized Timer Driver
Creation of a definition file (E.6.2)		Not needed	Not needed	Needed
Configurator	CFG_TIMUSE	Not checked	Checked	Checked
	Notes in E.6.3	Not relevant	Not relevant	Relevant
Modifying kernel_sys.h (E.6.4)		Not needed	Not needed	Needed
Timer driver to be linked		None	Standard timer driver	None (the optimized timer driver is included in the kernel library)

E.6.2 Creating the kernel_def_opttmr_set.h Definition File

The following settings for the optimized timer driver are defined in kernel_def_opttmr_set.h.

- hi_longtirate: the ratio low-precision cycle/high-precision cycle
- hi_pclock: the MCU's peripheral clock (P ϕ)

This file is included from the kernel_def.c and kernel_cfg.c.

(1) hi_longtirate

Format: #define hi_longtirate <setting value>

Specify the required result for low-precision cycle/high-precision cycle as an integer constant. The allowed range is from 2 to 0xff. If some other specification is made, the following error message will be displayed when kernel_def.c and kernel_cfg.c is compiled:

```
#error directive: "Illegal hi_longtirate"
```

Which setting is effective depends on the form (frequency or specified time) of the time-management functions most often used by the system. This is generally in the range from 5 to 50.

(2) hi_pclock

Format: `#define hi_pclock <setting value>`

Specify the frequency of the MCU's peripheral clock ($P\phi$) as a non-zero integer constant (Hz). If some other specification is made, the following error message will be displayed when `kernel_def.c` and `kernel_cfg.c` is compiled:

```
#error directive: "Illegal hi_pclock"
```

E.6.3 Notes on the Configurator

The following describes the items set in the configurator's [Time management function] page window.

(1) Timer interrupt number (CFG_TIMINTNO)

Specify 0x400 which means interrupt code for channel 0 of the TMU. If some other specification is made, the following error message will be displayed when `kernel_def.c` and `kernel_cfg.c` is compiled:

```
#error directive: "Illegal CFG_TIMINTNO"
```

The optimized timer driver uses the following interrupt codes:

- 0x400: Channel 0 of TMU
- 0x420: Channel 1 of TMU
- 0x440: Channel 2 of TMU

Do not define handlers for these interrupts.

When, however, the overrun handler is not in use (when the `def_ovr` service call has not been selected), 0x440 (channel 2) is not defined by the optimized timer driver. In this case, channel 2 is available for user.

(2) Timer interrupt level (CFG_TIMINTLVL)

Specify same value as the kernel interrupt mask level (CFG_KNLMSKLVL). If some other specification is made, the following error message will be displayed when `kernel_cfg.c` is compiled:

```
#error directive: "Illegal CFG_TIMINTLVL"
```

(3) Time-tick cycle (CFG_TICNUME and CFG_TICDENO)

The time-tick cycle is the period of a high-precision cycle.

E.6.4 Modifying kernel_sys.h

Add the following statement near the top of hisys\kernel_sys.h. This will include the contents of the definition file described above.

```
#ifndef _HIOS_KERNEL_SYS_H
#define _HIOS_KERNEL_SYS_H
#define OPTTMR /* ← Added. */
```

E.7 Kernel Libraries to be Used

For the kernel libraries to be used, refer to section 5.9, Kernel Libraries.

Appendix F DSP Standby Control (HI7700/4)

F.1 Overview

This function sets up an relation between hardware modules (DSP and X/Y memory) and the TA_COP0 attribute (indicating whether or not a task includes DSP calculation) for tasks and task-exception processing routines, and the kernel automatically places the related hardware modules in the module-standby state when tasks or task exception processing routines without TA_COP0 attribute are running (figure F.1). As a result, this function achieves low-power consumption. Following can be selected statically as hardware modules related to the TA_COP0 attribute.

- DSP only
- X/Y memory only
- DSP + X/Y memory

Appendix D DSP Standby Control (HI7700/4)

This function also supports the `vchg_cop` service call, which is used to dynamically change the `TA_COP0` attribute. Although it requires that applications be modified, using `vchg_cop` makes it possible to extend the periods over which hardware resources are placed in the module-standby state (figure F.1 (c)).

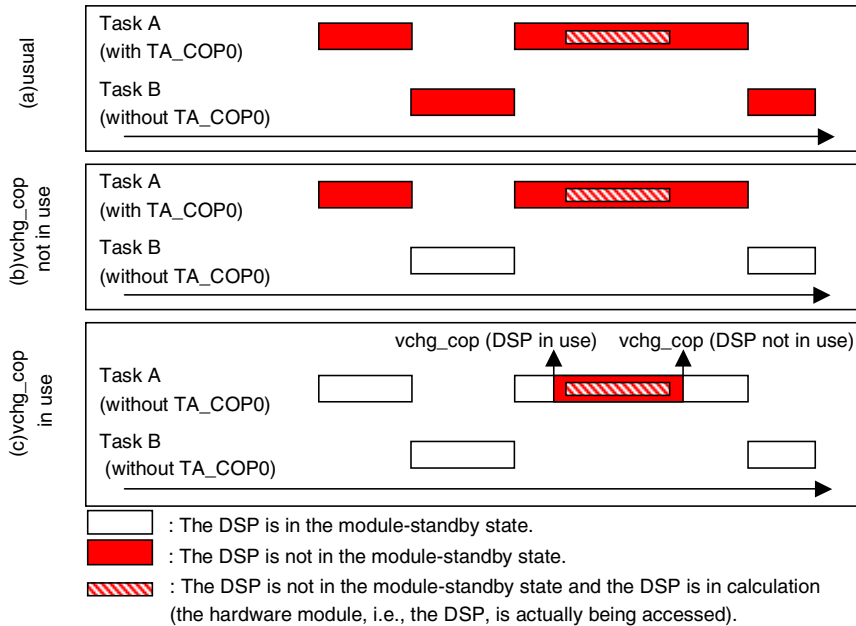

Figure F.1 Examples of Module-Standby Operation

F.2 Applicable MCUs

This function is only usable with MCUs that include a DSP, X/Y memory, or both, and at least one of the units has a module-standby function. At the time of writing, this specification applies to the following MCUs.

SH7727, SH7729R, SH7290, SH7294, SH7300, SH7641, SH7660, SH7710, SH7318, SH7343

F.3 Module-Standby State when Initiating Programs

When processing of a program is initiated and the DSP-standby control function has been included, the operation of the modules with which the TA_COP0 attribute has been related (DSP or X/Y memory) will be affected in different ways according to the type of program and whether or not the TA_COP0 attribute has been set for that program.

We recommended that handlers, i.e., programs of those types for which 'Undefined' are indicated in table F.1, be created such that they do not access modules associated with the TA_COP0 attribute. If such a module is to be used, have the program bring the module out of the standby state after saving the module's standby-state information on the program side, and return the module to the standby state before leaving the program.

Table F.1 Module Standby State at Initiating Programs

Program	Module-Standby State
Task	With TA_COP0: Non-standby Without TA_COP0: Standby
Task-exception processing routine	With TA_COP0: Non-standby Without TA_COP0: Standby
Expanded service-call routine	Same state as before the call
Interrupt handler	Undefined
CPU-exception handler	Undefined
Time-event handler	Undefined
Initialization routine	Undefined

When the kernel is idling (i.e., there is no executable task), a module associated with the TA_COP0 attribute enters the standby state.

F.4 Service Call for Changing the TA_COP0 Attribute (vchg_cop)

C-Language API:

```
ER_UINT oldatr = vchg_cop(ATR newatr);
```

Parameters:

ATR	newatr	R4	Attribute after changing
-----	--------	----	--------------------------

Return Parameters:

ER_UINT	oldatr	R0	Attribute before changing (0 or a positive value) or error code
---------	--------	----	-----------------------------------------------------------------

Error Codes:

E_RSATR	[p]	Invalid attribute (newatr is invalid)
E_CTX	[k]	Context error (Called from non-task context)

Function:

When this call is issue, the TA_COP0 attribute of the calling task is changed as newatr. Either of the following values can be specified for newatr:

```
newatr := TA_COP0 | TA_NULL
```

TA_COP0 (H'00000100): DSP is used

TA_NULL (H'00000000): DSP is not used

The value returned is oldatr, whether or not a TA_COP0 attribute was specified before this service call was issued.

TA_COP0: The TA_COP0 attribute was specified before the change.

TA_NULL: The TA_COP0 attribute was not specified before the change.

When vchg_cop is called from a task, the task's TA_COP0 attribute after task termination is restored to its state before the task was created.

When vchg_cop is called from a task-exception processing routine, the TA_COP0 attribute of the task-exception processing routine is changed but the TA_COP0 attribute of the task itself is not changed. When execution of the task-exception processing routine is completed, the routine's TA_COP0 attribute is restored to the state it was assigned when the routine was defined.

When TA_COP0 is specified for the task that does not have the TA_COP0 attribute, DSR is initialized to 0. The other DSP registers retain their values.

Frequently issuing this service call to switch the TA_COP0 attribute on and off will increase the overhead of module-standby control processing. Calling the service call to switch the attribute on and off should be in units of the occurrence of DSP-calculation.

Note that this service call is specific to the HI7700/4 and is not used for the service-call trace function.

F.5 Ways to Include DSP Standby Control Function

F.5.1 Overview

This section gives information that is supplementary to the standard configuration procedure. For details, see section 5, Configuration.

Table F.2 shows the procedures which must be followed to include the DSP-standby control function.

Table F.2 Including the DSP-Standby Control Function

Item	DSP-Standby Control Function not Included	DSP-Standby Control Function Included
Creation of a definition file (F.5.2)	Not needed	Needed
Modifying kernel_sys.h (F.5.3)	Not needed	Needed

Note that no item specifically determines whether or not the vchg_cop service call is available. Whenever the DSP-standby control function is included, the vchg_cop service call is included.

F.5.2 Creating the kernel_def_dspstby_set.h Definition File

The following information is defined in kernel_def_dspstby_set.h.

- hi_cop_stby_adr: Address of the module-standby control register
- hi_cop_stby_bit: Bit locations of the module-standby control register

When the kernel executes a task or exception processing routine with the TA_COP0 attribute, the bits indicated by hi_cop_stby_bit, which is indicated within an 8-bit unit (SH3-DSP) or 32-bit (SH4AL-DSP) of the address hi_cop_stby_adr, are set to 0. A module specified by hi_cop_stby_bit is thus placed in the non-standby state. On the other hand, when the kernel executes a task or exception processing routine without the TA_COP0 attribute, the bits indicated by hi_cop_stby_bit, which is indicated within an 8-bit unit (SH3-DSP) or 32-bit (SH4AL-DSP) of the address hi_cop_stby_adr, are set to 1. A module specified by hi_cop_stby_bit will be placed in the standby state.

The kernel_def_dspstby_set.h is included from kernel_def.c and kernel_cfg.c.

(1) hi_cop_stby_adr

Format: #define hi_cop_stby_adr <setting value>

Specify, as a non-zero integer constant, the address of the register that controls the module-standby state of the DSP or X/Y memory. If some other specification is made, the following error message will be displayed when kernel_def.c and kernel_cfg.c is compiled:

```
#error directive: "Illegal hi_cop_stby_adr"
```

(1) hi_cop_stby_bit

Format: #define hi_cop_stby_bit <setting value>

Specify the bit, which corresponds to the module to be controlled by this function in the register specified by hi_cop_stby_adr, with the integer constant. The ranges 1 to 0xff for SH3-DSP or 1 to 0xfffffff (SH4AL-DSP) can be specified. If some other range is specified, the following error message will be displayed when kernel_def.c and kernel_cfg.c is compiled:

```
#error directive: "Illegal hi_cop_stby_bit"
```

This specification determines the hardware modules that are associated with the TA_COP0 attribute.

Table F.3 shows the detailed values for specification with those SH3-DSP MCUs to which this function was applicable at the time of writing.

Table F.3 Value to be Specified for Each MCUs

MCU	hi_cop_stby_adr	DSP Only	hi_cop_stby_bit	
			X/Y Memory Only	DSP + X/Y Memory
SH7290, SH7294, SH7300, SH7641, SH7660, SH7710	0xa415ff88	0x10	0x1	0x11
SH7727, SH7729R	0xffffff88	(Not specifiable)	0x80	(Not specifiable)
SH7729	Not available			
SH7318, SH7343	0xa4150030	(Not specifiable)	0x4000000	(Not specifiable)

F.5.3 Modifying kernel_sys.h

Add the following statement near the top of hisys\kernel_sys.h. This will include the contents of the definition file described above.

```
#ifndef _HIOS_KERNEL_SYS_H
#define _HIOS_KERNEL_SYS_H
#define DSPSTBY /* ← Added. */
```

F.6 Kernel Libraries to be Used

For the kernel libraries to be used, refer to section 5.9, Kernel Libraries.

F.7 Notes

Since the X/Y memory uses much power, relating the X/Y memory with this function has a good effect on the levels of low-power consumption. However, note the following point with regard to DMA transfer.

When a task A with the TA_COP0 attribute specifies the X/Y memory as the source or destination of a DMA transfer and then starts the transfer, the transfer will not proceed correctly if task execution is switched to a task B that does not have the TA_COP0 attribute, since the kernel places the X/Y memory in module-standby mode during the execution of task B.

This is because access to the X/Y memory by the DMA is independent of the operation software, while the module-standby control of the X/Y memory is synchronized with task execution.

The following measures avert this problem:

- (1) Not applying the module-standby control function to the X/Y memory.
- (2) Not using DMA transfer with the X/Y memory.
- (3) Not switching tasks until the completion of the DMA transfer.

Appendix G Notes on FPU of SH2A-FPU, SH-4, SH4A

G.1 Task and Task Exception Processing Routine

G.1.1 Initialization of FPSCR

The initial value of FPSCR of a task and a task exception processing routine is shown below.

- SH-4, SH-4A: H'00040001 (FR = 0, SZ = 0, PR = 0, DN = 1, RM = B'01)
- SH2A-FPU:
TA_COP1 is specified: H'00040001 (SZ = 0, PR = 0, DN = 1, RM = B'01)
TA_COP1 is not specified: Undefined

When floating-point calculation is executed and when one of the following compiler options is specified, it is necessary to initialize FPSCR at the start of the entry function of the task and of the task exception processing routine.

- fpu = double
- denormalize = on
- round = nearest

Figure G.1 shows an example for initialization of FPSCR under the following conditions:

- cpu = sh4a
- fpu = double
- denormalize = on
- round = nearest

```
#include <machine.h> /* Included to use */
                        /* intrinsic function set_fpscr(). */
#define INI_FPSCR 0x00080000 /* FR=0, PR=1, DN=0, SZ=0, RM=B'00 */
#pragma noregsave(Task)
void Task(VP_INT exinf)
{
    set_fpscr(INI_FPSCR); /* Sets FPSCR at the start of function.
*/
    /* Task processing */
    ext_tsk();
}
```

Figure G.1 Example of Initialization of FPSCR in a Task

G.1.2 Attributes TA_COP1 and TA_COP2

Specify attributes TA_COP1 and TA_COP2 as described in table G.1

Table G.1 Specifying Attributes TA_COP1 and TA_COP2

Case	SH2A-FPU	SH-4, SH-4A
Matrix calculation (both FPU register banks used)	---	TA_COP1 TA_COP2
Normal floating-point calculation (only FPU register bank 0 is used.)	TA_COP1	TA_COP1
No floating-point calculation and "fpu=mix" is specified as compiler option.	TA_COP1 *	(Unnecessary)
No floating-point calculation, and "fpu=mix" is not specified as compiler option.	(Unnecessary)	(Unnecessary)

Note: This usage is not recommended.

G.2 Non-Task Context (Normal Interrupt Handler, Direct Interrupt Handler, CPU Exception Handler, Time Event Handler, Initialization Routine)

G.2.1 Overview

(1) Guarantee FPU Registers

When floating-point calculation is executed, these handlers need to guarantee all FPU registers.

(2) Guarantee FPSCR

When "fpu=mix" and "fpscr=aggressive" are specified as compiler options in SH2A-FPU, these handlers must guarantee the FPSCR register even if these handlers do not perform floating-point calculation.

When using SH-4 or SH-4A, these handlers do not have to guarantee the FPSCR register.

(3) Initialize FPSCR

The initial FPSCR value of CPU exception handler is the same as before CPU exception.

The initial FPSCR value of the other handlers is undefined.

When these handlers perform floating-point calculation, FPSCR must be initialized as shown in G.4.3, Handling by the Compiler at the start of the entry function of these handlers.

The following explains how to guarantee and initialize the registers.

G.2.2 SH-4, SH-4A

The HI7750/4 provides the following macros for the above operations.

These macros are defined in sh4fpu.h. The "code=asmcode" compiler option must be specified because these macros use in-line assemble function.

- (1) void IniFPU_ONEBANK(T_FPU_ONEBANK *pk_save, UW ini_fpscr)

When only the current FPU register bank is used, this macro should be used at the start of the handler function.

This macro saves the current FPU bank registers to the area pointed by pk_save, and initializes FPSCR to ini_fpscr.

- (2) void EndFPU_ONEBANK(T_FPU_ONEBANK *pk_save)

When only the current FPU register bank is used, this macro should be used at the end of the handler function.

This macro restores the current FPU bank register contents from the area pointed by pk_save.

- (3) void IniFPU_ALLBANK(T_FPU_ALLBANK *pk_save, UW ini_fpscr)

When both FPU register banks are used, this macro should be used at the top of the handler function.

This macro saves both FPU bank registers to the area pointed by pk_save, and initializes FPSCR to ini_fpscr.

- (4) void EndFPU_ALLBANK(T_FPU_ALLBANK *pk_save)

When both FPU register banks are used, this macro should be used at the end of the handler function.

This macro restores both FPU bank register contents from the area pointed by pk_save.

Figure G.2 shows an example of interrupt handler to initialize FPSCR and guarantee FPU registers.

```
#include <sh4fpu.h> /* Include "sh4fpu.h" */
#define INI_FPSCR 0x00040001 /* FR=0, PR=0, DN=1, SZ=0, RM=B'01 */
void HandlerMain(void) /* Handler main routine */
{
    /* Handler processing */
}

void Handler(void) /* Handler entry function */
{
    T_FPU_ONEBANK area; /* For saving FPU registers */
    IniFPU_ONEBANK(&area, INI_FPSCR); /* Save FPU registers and
                                     initialize FPSCR */
    HandlerMain(); /* Call HandlerMain() which performs
                   main processing*/
    EndFPU_ONEBANK(&area); /* Restore FPU registers */
}
```

Figure G.2 Example of Interrupt Handler to Initialize FPSCR and Guarantee FPU Registers (SH-4, SH-4A)

G.2.3 SH2A-FPU

The HI7000/4 provides the following macros for the above operations.

These macros are defined in sh2fapu.h. The "code=asmcode" compiler option must be specified because these macros use in-line assemble function.

(1) void IniFPU(VT_FPU *pk_save, UW ini_fpscr)

This macro should be used at the start of the handler function.

This macro saves FPU registers including FPSCR to the area pointed by pk_save, and initializes FPSCR to ini_fpscr.

(2) void EndFPU (VT_FPU *pk_save)

This macro should be used at the end of the handler function.

This macro restores FPU registers including FPSCR from the area pointed by pk_save.

Refer to figure G.2 for an example of interrupt handle. The interrupt handler for the SH2A-FPU differs from the example in figure G.2 only in the header file name and macro name.

G.3 Extended Service Call Routine

The compiler handles issuing of extended service calls as calling of functions.

G.3.1 Compiler Options

The compiler handles issuing of extended service calls as calling of functions. Therefore, the same settings should be made for the following compiler options between an extended service call routine and its caller.

- fpu option
- fpscr option
- denormalize option
- round option

When these options are different between the caller and the extended service call routine, note the following.

(1) Initialize FPSCR

At initiation, FPSCR.FR bits (FPU register bank) of SH-4 and SH-4A are the same as before an extended service call, and other FPSCR bits are determined by compiler options.

When floating-point calculation is executed in an extended service call routine, it is necessary to initialize FPSCR at the start of the entry function of the extended service call routine according to G.4.3, Handling by the Compiler.

(2) Guarantee FPSCR

When the extended service call routine is compiled with "fpu=mix" and "fpscr=aggressive" options, the extended service call needs to guarantee FPSCR explicitly.

Figure G.3 shows an example of extended service call routine to initialize and guarantee FPSCR register.

```
#include <machine.h> /* Include machine.h to use set_fpscr() */
#define INI_FPSCR 0x00080000 /* FR=0, PR=1, DN=0, SZ=0, RM=B'00 */
void ExtendedSVCRoutine(VP_INT par1)
{
    UW old_fpscr;
    old_fpscr = get_fpscr(); /* Save FPSCR */
    set_fpscr(INI_FPSCR); /* Initialize FPSCR */
    /* Extended service call routine processing */
    set_fpscr(old_fpscr); /* Restore FPSCR */
}
```

Figure G.3 Example of Extended Service Call Routine to Initialize and Guarantee FPSCR Register

G.3.2 Called from Task Context

Table G.2 shows the attributes required for the calling task and task exception processing routine.

Table G.2 Required Attributes TA_COP1 and TA_COP2 for Caller

Case	SH2A-FPU	SH-4, SH-4A
Matrix calculation (both FPU register banks used)	---	TA_COP1 TA_COP2
Normal floating-point calculation (only FPU register bank 0 is used.)	TA_COP1	TA_COP1
No floating-point calculation and "fpu=mix" is specified as compiler option.	TA_COP1 *	(Unnecessary)
No floating-point calculation, and "fpu=mix" is not specified as compiler option.	(Unnecessary)	(Unnecessary)

Note: This usage is not recommended.

G.3.3 Called from Non-Task Context

When floating-point calculation is executed, the calling programs such as an interrupt handler need to guarantee all FPU registers. For details, refer to appendix G.2, Non-Task Context (Normal Interrupt Handler, Direct Interrupt Handler, CPU Exception Handler, Time Event Handler, Initialization Routine).

G.4 Information for Reference

G.4.1 States on the Initiation of Tasks and Handlers

Table G.3 shows the FPSCR states on the initiation of tasks and handlers

Table G.3 States on the Initiation of Tasks and Handlers

State at Initiation	Task and Task Exception Processing Routine	Extended Service Call Routine	Interrupt and Time Event Handler, and Initialization Routine	CPU Exception Handler (Including TRAPA)
Value of FPSCR	H'00040001	Same as before the extended service call was issued	Undefined	Same as before the exception occurred
Precision mode (FPSCR.PR)	Single precision (0)			
Denormalization mode (FPSCR.DN) *1	Handled as zero (1)			
Rounding mode (FPSCR.RM)	Rounded to zero (B'01)			
Transfer size mode (FPSCR.SZ)	32 bits (0)			
FPU register bank (FPSCR.FR) *2	Bank 0 (0)			
Other bits of FPSCR	0			

Notes: 1. In SH2A-FPU, DN is always 1.

2. Only in SH-4 and SH-4A

G.4.2 FPSCR Structure

31	22	21	20	19	18	17	12	11	7	6	2	1	0
Reserved	FR	SZ	PR	DN	Cause			Enable		Flag		RM	

Bit		Meaning		
21	FR	FPU register bank *1	0	Bank 0
			1	Bank 1
20	SZ	Transfer size mode	0	The data size of the FMOV instruction is 32 bits.
			1	The data size of the FMOV instruction is a 32-bit register pair (64 bits).
19	PR	Precision mode	0	Single precision
			1	Double precision
18	DN	Denormalization mode *2	0	A denormalized number is treated as such.
			1	A denormalized number is treated as zero.
17-12	Cause	FPU exception factor field		
11-7	Enable	FPU exception enable field		
6-2	Flag	FPU exception flag field		
1,0	RM	Rounding mode	B'00	Round to Nearest
			B'01	Round to Zero

- Notes: 1. Only in SH-4 and SH-4A
 2. In SH2A-FPU, DN is always 1.

G.4.3 Handling by the Compiler

This section explains handling by compiler. The compiler never generates any object code to change the FPSCR when "Single" or "Double" has been specified as the FPU option.

(1) FPSCR.PR (Precision mode)

Table G.4 Handling of the FPSCR.PR Bit by the Compiler

Compiler Option		Precision Mode Assumed by the Compiler on Entry to Functions (FPSCR.PR Bit)* ¹	Precision Mode at the End of the Function* ²	Remarks
FPU Option	FPSCR Option * ³			
Single	(Specification disabled)	Single precision (0)	Single precision (0)	The compiler does not generate any object code to change the PR bit.
Double	(Specification disabled)	Double precision (1)	Double precision (1)	
No specification (Mix)	Safe	Single precision (0)	Single precision (0)	
	Aggressive	Single precision (0)	Undefined	

Notes: 1. The compiler assumes this precision mode in generating code at the top of the function.
 2. The compiler generates code to select this precision mode at the end of the function.
 3. Compiler V5.1 does not support this FPSCR option; treatment is the same as 'aggressive'.

(2) FPSCR.DN (Denormalization mode) (only in SH-4 and SH-4A)

Table G.5 Handling of the FPSCR.DN Bit by the Compiler

Compiler Option	Denormalization Mode Assumed by the Compiler (FPSCR.DN Bit)*	Remarks
Denormalize Option		
OFF	A denormalized number is treated as zero. (1)	The compiler does not generate any object code to change the DN bit.
ON	A denormalized number is treated as such. (0)	

Note: The compiler assumes this denormalization mode in generating code at the top of the function.

(1) FPSCR.RM (Rounding mode)

Table G.6 Handling of the FPSCR.RM Bits by the Compiler

Compiler Option	Denormalization Mode Assumed by the Compiler (FPSCR.DN Bit)*	Remarks
Zero	Round to Zero (B'01)	The compiler does not generate any object code to change the RM bits.
Nearest	Round to Nearest (B'00)	

Note: The compiler assumes this rounding mode in generating code at the top of the function.

(2) FPSCR.SZ (transfer size mode)

The compiler always assumes SZ = 0 (the data size of the FMOV instruction is 32 bits.) and does not generate any object code to change the SZ bit.

(3) FPSCR.FR (FPU register bank) (only in SH-4 and SH-4A)

The compiler does not generate any object code to change the FR bit.

However, in the built-in functions `st_ext()` and `ld_ext()`, the FR bit is temporarily changed within these function. The value of the FR bit on return from these functions is the same as the value when the function was called.

Appendix H New Functions of HI7000/4 V.2

H.1 Support of SH-2A and SH2A-FPU

H.1.1 FPU (SH2A-FPU) (V.2.00 Release 00)

The TA_COP1 attribute is added for tasks and task exception processing routines.

When TA_COP1 is specified, the FPU registers are added as context registers for the task and the task exception processing routine and the FPU can be used in a multitasking environment.

The [Uses FPU(TA_COP1)] check box is added to [Creation of Task] and [Definition of Task Exception Processing Routine] dialog box of the configurator,

Related Pages:

- p.76: Section 3.4.1, Create Task
- p.111: Section 3.6.1, Define Task Exception Processing Routine (def_tex, idef_tex)
- p.373: Section 5.11.1, CPU Options for the Compiler and Assembler
- p. 437: Appendix G, Notes on FPU of SH2A-FPU, SH-4, SH4A

H.1.2 TBR Register (V.2.00 Release 00)

As the usage of TBR register, one of the following three can be chosen.

- (1) Kernel does not manage
- (2) Only for service call
- (3) Task context

This is chosen by CFG_TBR in the [Kernel Execution Condition] page of configurator.

Related Pages:

- p.295: Section 4.2.8, TBR Register (SH-2A, SH2A-FPU)
- p. 356: Item No. 1.4 in table 5.5 of section 5.4.6, Configurator Settings
- p.373: Section 5.11.1, CPU Options for the Compiler and Assembler

H.1.3 Register Banks (V.2.00 Release 00, V.2.01 Release 00 and V.2.02 Release 00)

In V.2.00 Release 00, the [CFG_REGBANK] checkbox was included, allowing selection of whether or not to use register banks with all interrupts other than the NMI and UBC interrupts.

In V.2.02 Release 00, the [CFG_REGBANK] checkbox was replaced by a combo box, extending the above capability by allowing the user to select whether or not to use register banks with interrupts at each of the individual interrupt priority levels.

Moreover, in V.2.01 Release 00, the [CFG_IBNR_ADR] edit box was added to the [Interrupt Handler/CPU Exception Handler] page of the configurator, allowing selection of the IBNR address for the register banks. This edit box was necessary because a fixed IBNR address of H' fffe080e was assumed in previous versions of the kernel. Since the IBNR of some processors is allocated to different addresses, the previous fixed setting did not allow usage of the register banks in these processors.

Related Pages:

- p. 296: Section 4.2.9, Register Banks (SH-2A, SH2A-FPU)
- p.307: Section 4.8, Interrupt Handlers
- p.359: Item No. 6.5 and 6.6 in table 5.5 of section 5.4.6, Configurator Settings

H.2 Specifying Address of Task Stack, Fixed-Size Memory Pool, and Variable-Size Memory Pool (V.2.00 Release 00)

In the previous version, it was not possible to specify the addresses of task stacks, fixed-size memory pools, and variable-size memory pools at the time of creation of these objects. These areas were always allocated to respective specific areas managed by the kernel.

In V.2, the user can also allocate each area and can specify the address at each object creation.

Thereby, the user can allocate each task stack or memory pool area to an arbitrary memory address according to the purpose of use. For example, only a specific task uses a stack in the high-speed on-chip RAM.

Related Pages:

- p.13: Section 2.6.2, Task Creation
- p. 76: Section 3.4.1, Create Task
- p. 176: Section 3.13.1, Create Fixed-Size Memory Pool
- p. 186: Section 3.14.1, Create Variable-Size Memory Pool

H.3 Management Method of Fixed-Size Memory Pool (V.2.00 Release 00)

In the previous version, the kernel management table for each memory block is allocated in the memory pool area.

In V.2, the user can also allocate the management table area and can specify the table area address at creation. In this case, the memory pool area does not include management tables.

By combining this management method with the new function given in appendix H.2, Specifying Address of Task Stack, Fixed-Size Memory Pool, and Variable-Size Memory Pool, a memory block can be acquired with a specific offset address as follows for example.

- Parameters for fixed-size memory pool creation
 - Address of fixed-size memory pool = H'0c000000
 - Block size = H'1000 (4 Kbytes)
 - Number of blocks = 4

In this case, one of memory blocks [A], [B], [C], and [D] shown below is acquired. Each memory block is aligned with a 4-Kbyte boundary.

Address	
H'0C000000 -->	Memory block [A]
H'0C001000 -->	Memory block [B]
H'0C002000 -->	Memory block [C]
H'0C003000 -->	Memory block [D]

In this new management method, member mpfmb is added to the T_CMPF structure which is used to create fixed-size memory pool. The mpfmb member indicates the address of the management table area.

The conventional or new management method is chosen by CFG_MPFMANAGE in [Fixed-size Memory Pool] page of the configurator.

Note that both methods cannot be used simultaneously.

Related Pages:

- p. 176: Section 3.13.1, Create Fixed-Size Memory Pool
- p. 356: Item No. 17.3 in table 5.5 of section 5.4.6, Configurator Settings

H.4 Direct Interrupt Handler (V.2.00 Release 00 and V.2.02 Release 00)

In the previous version (V1), issuing of service calls by direct interrupt handlers was forbidden.

In V.2.00 Release 00, direct interrupt handlers can issue service calls.

Note that the direct interrupt handler which level is higher than the kernel interrupt mask level (CFG_KNLMSKLV) must not call a service call. This specification is the same as the previous version.

In V.2.02 Release 00, it is also possible to define a direct interrupt handler by issuing a `def_inh` or `idef_inh` service call.

H.5 Macros for Calculating Size (V.2.00 Release 00)

The following macros are added.

- (1) `SIZE mpfsz = TSZ_MPF(UINT blkcnt, UINT blkksz)`

The size of fixed-size memory pool area required to hold the `blkcnt` number of `blkksz`-byte memory blocks (bytes)

- (2) `SIZE size = VTSZ_MPFMB(UINT blkcnt, UINT blkksz)`

The size of fixed-size memory pool management area required to hold the `blkcnt` number of `blkksz`-byte memory blocks (bytes)

- (3) `SIZE mplsiz = TSZ_MPL(UINT blkcnt, UINT blkksz)`

The size of variable-size memory pool area required to hold the `blkcnt` number of `blkksz`-byte memory blocks (target byte size)

Related Pages:

- p.290: Table 4.1 in section 4.1.1, Header File

H.6 Extension of Maximum Vector Number (V.2.00 Release 00)

The maximum vector number that can be specified for `CFG_MAXVCTNO` through the configurator is extended from 255 to 511.

Related Pages:

- p.236: Table 3.62 in section 3.20, Interrupt Management
- p. 245: Table 3.68 in section 3.22, System Configuration Management

H.7 ID Name (V.2.00 Release 00)

In the previous version, ID names can be specified only when ID numbers are automatically assigned.

In V.2, ID names can be specified to all objects.

Table H.1 shows the additional functions in V.2 about ID names.

Table H.1 Additional Functions about ID Names

Version	Kernel Side (kernel_id_sys.h)		Kernel Environment Side (kernel_id.h)	
	Automatic ID Number Assignment	Specify ID Name	Automatic ID Number Assignment	Specify ID Name
Previous version	Impossible	Impossible	Possible	Possible only for specifying "Auto" as ID Number
V.2.00 or later		Possible		Possible

Related Pages:

- p.292: Section 4.1.1(3), Header Files for ID Name
- p. 353: Section 5.4.4(1), kernel_id.h, kernel_id_sys.h

H.8 Support of Little Endian in SH-2 (V.2.00 Release 01)

V.2.00 Release 01 supports the little endian mode in the SH-2.

H.9 Improvement of Variable-Size Memory Pool (V.2.01 Release 00)

Selecting CFG_NEWMPL added to the configurator allows the following improvements.

- (1) The performance to acquire and release memory blocks

In applications that use a large number of memory blocks, the performance to acquire and release memory blocks are faster than when CFG_NEWMPL is not selected.

- (2) Reduced fragmentation of free space

Selecting CFG_NEWMPL generally retards the fragmentation of free memory space, but the newly supported VTA_UNFRAGMENT attribute further reduces fragmentation. Although specifying the VTA_UNFRAGMENT attribute generally helps in reducing fragmentation, the degree of fragmentation depends on how the memory pools are used.

To support the VTA_UNFRAGMENT attribute, the following macro has been added.

```
SIZE mpsz = VTSZ_MPLMB(UINT sctnum)
```

Size of the management area for variable-size memory pool with attribute VTA_UNFRAGMENT (bytes)

When CFG_NEWMPL is selected, new members mpfmb, minblksz, and sctnum are added to the T_CMPL structure which is used to create variable-size memory pool. Member mpfmb indicates the address of the management table area, minblksz indicates the minimum block size, and sctnum indicates the number of sectors. These settings are ignored when the VTA_UNFRAGMENT attribute is not specified.

Note, the use size of stack increases generally when CFG_NEWMPL is selected.

Related Pages:

- p. 40: Section 2.15.2, Controlling Fragmentation of Free Space
- p. 186: Section 3.14.1, Create Variable-Size Memory Pool
- p. 363: Item No. 18.3 in table 5.5 of section 5.4.6, Configurator Settings
- p. 405: Appendix C Calculation of Work Area Size

H.10 Initial Value of DSR (V.2.01 Release 00)

The initial value of DSR in the task with the TA_COP0 attribute and its task exception processing routine is changed from an undefined value to 0.

Related Pages:

- p. 337: Section 4.13, Using the DSP in Programs (for HI7000/4 and HI7700/4 only)

H.11 Initial Value of SR in Task Exception Processing Routine (V.2.01 Release 00)

The initial value of SR in the task exception processing routine is changed as follows.

Previous version: Same value as in the task before initiation

V.2.01: H'00000000

H.12 Handling of Vector Numbers 16 to 31 (V.2.01 Release 00)

Handlers can be defined for all of these vector numbers in V.2.01 Release 00. In V.2.02 Release 00, however, no handler can be defined for vector number 26 because it is now used by the kernel.

H.13 Lifting of Restriction concerning Structure Alignment (V.2.01 Release 00)

In the previous version, there is a restriction regarding the pack option and #pragma pack directive for the compiler. This restriction does not apply with V.2.01 and the following related note has been removed from this version of the user's manual.

The source program which uses the variable of the structure form defined by the kernel should surely specify "pack=4". Moreover, do not declare the variable of the structure form defined by the kernel as "#pragma pack 1". For kernel_def.c and kernel_cfg.c, be sure to specify "pack=4" as an option of the compiler.

H.14 [Open the file used last time] Command for the Configurator (V.2.02 Release 00)

A new [Options] menu has been added to the menu bar and contains an [Open the file used last time] item. If you select this item, the configurator will automatically open the last file to be used whenever it starts up.

Appendix I New Functions of HI7700/4 V.2

I.1 Support of SH4AL-DSP (with Extended Function) (V.2.01 Release 00)

The cache support library (shx2_cache_???.lib) for the SH4AL-DSP (with extended function) is added.

I.2 Specifying Address of Task Stack, Fixed-Size Memory Pool, and Variable-Size Memory Pool (V.2.01 Release 00)

In the previous version, it was not possible to specify the addresses of task stacks, fixed-size memory pools, and variable-size memory pools at the time of creation of these objects. These areas were always allocated to respective specific areas managed by the kernel.

In V.2, the user can also allocate each area and can specify the address at each object creation.

Thereby, the user can allocate each stack or memory pool area to an arbitrary memory address according to the purpose of use. For example, only a specific task uses a stack in the high-speed on-chip RAM.

Related Pages:

- p. 13: Section 2.6.2, Task Creation
- p. 76: Section 3.4.1, Create Task
- p. 176: Section 3.13.1, Create Fixed-Size Memory Pool
- p. 186: Section 3.14.1, Create Variable-Size Memory Pool

I.3 Management Method of Fixed-Size Memory Pool (V.2.01 Release 00)

In the previous version, the kernel management table for each memory block is allocated in the memory pool area.

In V.2, the user can also allocate the management table area and can specify the table area address at creation. In this case, the memory pool area does not include management tables.

Appendix I New Functions of HI7700/4 V2

By combining this management method with the new function given in appendix I.2, Specifying Address of Task Stack, Fixed-Size Memory Pool, and Variable-Size Memory Pool (V.2.01 Release 00), a memory block can be acquired with a specific offset address as follows for example.

- Parameters for fixed-size memory pool creation
 - Address of fixed-size memory pool = H'0c000000
 - Block size = H'1000 (4 Kbytes)
 - Number of blocks = 4

In this case, one of memory blocks [A], [B], [C], and [D] shown below is acquired. Each memory block is aligned with a 4-Kbyte boundary.

Address	
H'0C000000 -->	Memory block [A]
H'0C001000 -->	Memory block [B]
H'0C002000 -->	Memory block [C]
H'0C003000 -->	Memory block [D]

In this new management method, member mpfmb is added to the T_CMPF structure which is used to create fixed-size memory pool. The mpfmb member indicates the address of the management table area.

The conventional or new management method is chosen by CFG_MPFMANAGE in [Fixed-size Memory Pool] page of the configurator.

Note that both methods cannot be used simultaneously.

Related Pages:

- p. 176: Section 3.13.1, Create Fixed-Size Memory Pool (cre_mpf, icre_mpf)
- p. 356: Item No. 17.3 in table 5.5 of section 5.4.6, Configurator Settings

I.4 Improvement of Variable-Size Memory Pool (V.2.01 Release 00)

Selecting CFG_NEWMPL added to the configurator allows the following improvements.

(1) The performance to acquire and release memory blocks

In applications that use a large number of memory blocks, the performance to acquire and release memory blocks are faster than when CFG_NEWMPL is not selected.

(2) Reduced fragmentation of free space

Selecting CFG_NEWMPL generally retards the fragmentation of free memory space, but the newly supported VTA_UNFRAGMENT attribute further reduces fragmentation. Although specifying the VTA_UNFRAGMENT attribute generally helps in reducing fragmentation, the degree of fragmentation depends on how the memory pools are used.

To support the VTA_UNFRAGMENT attribute, the following macro has been added.

```
SIZE mplsz = VTSZ_MPLMB(UINT sctnum)
```

Size of the management area for variable-size memory pool with attribute VTA_UNFRAGMENT (bytes)

When CFG_NEWMPL is selected, new members mpfmb, minblksz, and sctnum are added to the T_CMPL structure which is used to create variable-size memory pool. Member mpfmb indicates the address of the management table area, minblksz indicates the minimum block size, and sctnum indicates the number of sectors. These settings are ignored when the VTA_UNFRAGMENT attribute is not specified.

Note, the use size of stack increases generally when CFG_NEWMPL is selected.

Related Pages:

- p. 40: Section 2.15.2, Controlling Fragmentation of Free Space
- p. 186: Section 3.14.1, Create Variable-Size Memory Pool (cre_mpl, icre_mpl)
- p. 363: Item No. 18.3 in table 5.5 of section 5.4.6, Configurator Settings
- p. 405: Appendix C Calculation of Work Area Size

I.5 Macros for Calculating Size (V.2.01 Release 00)

The following macros are added.

- (1) $\text{SIZE mpfsz} = \text{TSZ_MPF}(\text{UINT blkcnt}, \text{UINT blkksz})$
The size of fixed-size memory pool area required to store the blkcnt number of blkksz-byte memory blocks (bytes)
- (2) $\text{SIZE size} = \text{VTSZ_MPFMB}(\text{UINT blkcnt}, \text{UINT blkksz})$
The size of fixed-size memory pool management area required to hold the blkcnt number of blkksz-byte memory blocks (bytes)
- (3) $\text{SIZE mpls} = \text{TSZ_MPL}(\text{UINT blkcnt}, \text{UINT blkksz})$
The size of variable-size memory pool area required to hold the blkcnt number of blkksz-byte memory blocks (target byte size)
- (4) $\text{SIZE mpls} = \text{VTSZ_MPLMB}(\text{UINT sctnum})$
The size of management area for variable-size memory pool with the VTA_UNFRAGMENT attribute (bytes)

Related Pages:

- p.290: Table 4.1 in section 4.1.1, Header File

I.6 Initial Value of DSR (V.2.01 Release 00)

The initial value of DSR in the task with the TA_COP0 attribute and its task exception processing routine is changed from an undefined value to 0. Note that this change also applies to V.1.03 Release 02.

When the TA_COP0 specification is switched from off to on through the vchg_cop service call, the kernel does not initialize DSR in the previous version, but in V.2.01, the kernel initializes it to 0.

Related Pages:

- p. 337: Section 4.13, Using the DSP in Programs (for HI7000/4 and HI7700/4 only)

I.7 Initial Value of SR in Task Exception Processing Routine (V.2.01 Release 00)

The initial value of SR in the task exception processing routine is changed as follows.

Previous version: Same value as in the task before initiation

V.2.01: H'40001000 when either CFG_DSP or CFG_CACLOC is selected, or H'40000000 when neither of them is selected

I.8 Extension of Maximum Exception Code (CFG_MAXVCTNO) (V.2.01 Release 00)

The maximum exception code that can be specified for CFG_MAXVCTNO through the configurator is extended from 0xfe0 to 0x3fe0.

I.9 Handling of TRAPA #16 to #31 (V.2.01 Release 00)

Trap exception handlers can be defined for these numbers in V.2.01.

I.10 Release of Restriction concerning Structure Alignment (V.2.01 Release 00)

In the previous version, there is a restriction about the pack option and #pragma pack of the compiler. This restriction is not applied to V.2.01 and the following related note is removed from this user's manual.

The source program which uses the variable of the structure form defined by the kernel should surely specify "pack=4". Moreover, do not declare the variable of the structure form defined by the kernel as "#pragma pack 1". For kernel_def.c and kernel_cfg.c, be sure to specify "pack=4" as an option of the compiler.

I.11 ID Name (V.2.01 Release 00)

In the previous version, ID names can be specified only when ID numbers are automatically assigned.

In V.2, ID names can be specified to all objects.

Table I.1 shows the additional functions in V.2 about ID names.

Table I.1 Additional Functions about ID Names

Version	Kernel Side (kernel_id_sys.h)		Kernel Environment Side (kernel_id.h)	
	Automatic ID Number Assignment	Specify ID Name	Automatic ID Number Assignment	Specify ID Name
Previous version	Impossible	Impossible	Possible	Possible only for specifying "Auto" as ID Number
V.2.01 or later		Possible		Possible

Related Pages:

- p.292: Section 4.1.1(3), Header Files for ID Name
- p. 353: Section 5.4.4(1), kernel_id.h, kernel_id_sys.h

I.12 [Open the file used last time] Command for the Configurator (V.2.02 Release 00)

A new [Options] menu has been added to the menu bar and contains an [Open the file used last time] item. If you select this item, the configurator will automatically open the last file to be used whenever it starts up.

Appendix J New Functions of HI7750/4 V.2

J.1 Support of SH-4A (with Extended Function) (V.2.01 Release 00)

The cache support library (shx2_cache_???.lib) for the SH-4A (with extended function) is added.

J.2 Specifying Address of Task Stack, Fixed-Size Memory Pool, and Variable-Size Memory Pool (V.2.01 Release 00)

In the previous version, it was not possible to specify the addresses of task stacks, fixed-size memory pools, and variable-size memory pools at the time of creation of these objects. These areas were always allocated to respective specific areas managed by the kernel.

In V.2, the user can also allocate each area and can specify the address at each object creation.

Thereby, the user can allocate each stack or memory pool area to an arbitrary memory address according to the purpose of use. For example, only a specific task uses a stack in the high-speed on-chip RAM.

Related Pages:

- p.13: Section 2.6.2, Task Creation
- p. 76: Section 3.4.1, Create Task
- p. 176: Section 3.13.1, Create Fixed-Size Memory Pool (cre_mpf, icre_mpf)
- p. 186: Section 3.14.1, Create Variable-Size Memory Pool (cre_mpl, icre_mpl)

J.3 Management Method of Fixed-Size Memory Pool (V.2.01 Release 00)

In the previous version, the kernel management table for each memory block is allocated in the memory pool area.

In V.2, the user can also allocate the management table area and can specify the table area address at creation. In this case, the memory pool area does not include management tables.

Appendix J New Functions of HI7750/4 V2

By combining this management method with the new function given in appendix J.2, Specifying Address of Task Stack, Fixed-Size Memory Pool, and Variable-Size Memory Pool (V.2.01 Release 00), a memory block can be acquired with a specific offset address as follows for example.

- Parameters for fixed-size memory pool creation
 - Address of fixed-size memory pool = H'0c000000
 - Block size = H'1000 (4 Kbytes)
 - Number of blocks = 4

In this case, one of memory blocks [A], [B], [C], and [D] shown below is acquired. Each memory block is aligned with a 4-Kbyte boundary.

Address	
H'0C000000 -->	Memory block [A]
H'0C001000 -->	Memory block [B]
H'0C002000 -->	Memory block [C]
H'0C003000 -->	Memory block [D]

In this new management method, member `mpfmb` is added to the `T_CMPF` structure which is used to create fixed-size memory pool. The `mpfmb` member indicates the address of the management table area.

The conventional or new management method is chosen by `CFG_MPFMANAGE` in [Fixed-size Memory Pool] page of the configurator.

Note that both methods cannot be used simultaneously.

Related Pages:

- p. 176: Section 3.13.1, Create Fixed-Size Memory Pool (`cre_mpf`, `icre_mpf`)
- p. 356: Item No. 17.3 in table 5.5 of section 5.4.6, Configurator Settings

J.4 Improvement of Variable-Size Memory Pool (V.2.01 Release 00)

Selecting CFG_NEWMPL added to the configurator allows the following improvements.

(1) The performance to acquire and release memory blocks

In applications that use a large number of memory blocks, the performance to acquire and release memory blocks are faster than when CFG_NEWMPL is not selected.

(2) Reduced fragmentation of free space

Selecting CFG_NEWMPL generally retards the fragmentation of free memory space, but the newly supported VTA_UNFRAGMENT attribute further reduces fragmentation. Although specifying the VTA_UNFRAGMENT attribute generally helps in reducing fragmentation, the degree of fragmentation depends on how the memory pools are used.

To support the VTA_UNFRAGMENT attribute, the following macro has been added.

```
SIZE mplsz = VTSZ_MPLMB(UINT sctnum)
```

Size of the management area for variable-size memory pool with attribute VTA_UNFRAGMENT (bytes)

When CFG_NEWMPL is selected, new members mpfmb, minblksz, and sctnum are added to the T_CMPL structure which is used to create variable-size memory pool. Member mpfmb indicates the address of the management table area, minblksz indicates the minimum block size, and sctnum indicates the number of sectors. These settings are ignored when the VTA_UNFRAGMENT attribute is not specified.

Note, the use size of stack increases generally when CFG_NEWMPL is selected.

Related Pages:

- p. 40: Section 2.15.2, Controlling Fragmentation of Free Space
- p. 186: Section 3.14.1, Create Variable-Size Memory Pool (cre_mpl, icre_mpl)
- p. 363: Item No. 18.3 in table 5.5 of section 5.4.6, Configurator Settings
- p. 405: Appendix C, Calculation of Work Area Size

J.5 Macros for Calculating Size (V.2.01 Release 00)

The following macros are added.

- (1) `SIZE mpfsz = TSZ_MPF(UINT blkcnt, UINT blkksz)`
The size of fixed-size memory pool area required to store the blkcnt number of blkksz-byte memory blocks (bytes)
- (2) `SIZE size = VTSZ_MPFMB(UINT blkcnt, UINT blkksz)`
The size of fixed-size memory pool management area required to hold the blkcnt number of blkksz-byte memory blocks (bytes)
- (3) `SIZE mplsiz = TSZ_MPL(UINT blkcnt, UINT blkksz)`
The size of variable-size memory pool area required to hold the blkcnt number of blkksz-byte memory blocks (target byte size)
- (4) `SIZE mplsiz = VTSZ_MPLMB(UINT sctnum)`
The size of management area for variable-size memory pool with the VTA_UNFRAGMENT attribute (bytes)

Related Pages:

- p.290: Table 4.1 in section 4.1.1, Header File

J.6 Initial Value of SR in Task Exception Processing Routine (V.2.01 Release 00 or Later)

The initial value of SR in the task exception processing routine is changed as follows.

Previous version: Same value as in the task before initiation

V.2.01: H'40000000

J.7 Extension of Maximum Exception Code (CFG_MAXVCTNO) (V.2.01 Release 00)

The maximum exception code that can be specified for CFG_MAXVCTNO) through the configurator is extended from 0xfe0 to 0x3fe0.

J.8 Handling of TRAPA #16 to #31 (V.2.01 Release 00)

Trap exception handlers can be defined for these numbers in V.2.01.

J.9 Release of Restriction concerning Structure Alignment (V.2.01 Release 00)

In the previous version, there is a restriction about the pack option and #pragma pack of the compiler. This restriction is not applied to V.2.01 and the following related note is removed from this user's manual.

The source program which uses the variable of the structure form defined by the kernel should surely specify "pack=4". Moreover, do not declare the variable of the structure form defined by the kernel as "#pragma pack 1". For kernel_def.c and kernel_cfg.c, be sure to specify "pack=4" as an option of the compiler.

J.10 ID Name (V.2.01 Release 00)

In the previous version, ID names can be specified only when ID numbers are automatically assigned.

In V.2, ID names can be specified to all objects.

Table J.1 shows the additional functions in V.2 about ID names.

Table J.1 Additional Functions about ID Names

Version	Kernel Side (kernel_id_sys.h)		Kernel Environment Side (kernel_id.h)	
	Automatic ID Number Assignment	Specify ID Name	Automatic ID Number Assignment	Specify ID Name
Previous version	Impossible	Impossible	Possible	Possible only for specifying "Auto" as ID Number
V.2.01 or later		Possible		Possible

Related Pages:

- p.292: Section 4.1.1(3), Header Files for ID Name
- p. 353: Section 5.4.4(1), kernel_id.h, kernel_id_sys.h

J.11 [Open the file used last time] Command for the Configurator (V.2.02 Release 00)

A new [Options] menu has been added to the menu bar and contains an [Open the file used last time] item. If you select this item, the configurator will automatically open the last file to be used whenever it starts up.

**Renesas Microcomputer Development Environment System
User's Manual
HI7000/4 Series (HI7000/4 V.2.02, HI7700/4 V.2.02,
and HI7750/4 V.2.02)**

Publication Date: Rev.6.00, January 4, 2006
Published by: Sales Strategic Planning Div.
Renesas Technology Corp.
Edited by: Customer Support Department
Global Strategic Communication Div.
Renesas Solutions Corp.

Renesas Technology Corp. Sales Strategic Planning Div. Nippon Bldg., 2-6-2, Ohte-machi, Chiyoda-ku, Tokyo 100-0004, Japan



RENESAS SALES OFFICES

<http://www.renesas.com>

Refer to "<http://www.renesas.com/en/network>" for the latest and detailed information.

Renesas Technology America, Inc.
450 Holger Way, San Jose, CA 95134-1368, U.S.A
Tel: <1> (408) 382-7500, Fax: <1> (408) 382-7501

Renesas Technology Europe Limited
Dukes Meadow, Millboard Road, Bourne End, Buckinghamshire, SL8 5FH, U.K.
Tel: <44> (1628) 585-100, Fax: <44> (1628) 585-900

Renesas Technology (Shanghai) Co., Ltd.
Unit 205, AZIA Center, No.133 Yincheng Rd (n), Pudong District, Shanghai 200120, China
Tel: <86> (21) 5877-1818, Fax: <86> (21) 6887-7898

Renesas Technology Hong Kong Ltd.
7th Floor, North Tower, World Finance Centre, Harbour City, 1 Canton Road, Tsimshatsui, Kowloon, Hong Kong
Tel: <852> 2265-6688, Fax: <852> 2730-6071

Renesas Technology Taiwan Co., Ltd.
10th Floor, No.99, Fushing North Road, Taipei, Taiwan
Tel: <886> (2) 2715-2888, Fax: <886> (2) 2713-2999

Renesas Technology Singapore Pte. Ltd.
1 Harbour Front Avenue, #06-10, Keppel Bay Tower, Singapore 098632
Tel: <65> 6213-0200, Fax: <65> 6278-8001

Renesas Technology Korea Co., Ltd.
Kukje Center Bldg. 18th Fl., 191, 2-ka, Hangang-ro, Yongsan-ku, Seoul 140-702, Korea
Tel: <82> (2) 798-3115, Fax: <82> (2) 796-2145

Renesas Technology Malaysia Sdn. Bhd
Unit 906, Block B, Menara Amcorp, Amcorp Trade Centre, No.18, Jalan Persiaran Barat, 46050 Petaling Jaya, Selangor Darul Ehsan, Malaysia
Tel: <603> 7955-9390, Fax: <603> 7955-9510



HI7000/4 Series
(HI7000/4 V.2.02, HI7700/4 V.2.02, and HI7750/4 V.2.02)
User's Manual



Renesas Technology Corp.
2-6-2, Ote-machi, Chiyoda-ku, Tokyo, 100-0004, Japan